



ENTERED

F 2302

# San Francisco Law Library

426 CITY HALL

No. 162082

---

## EXTRACT FROM RULES

Rule 1a. Books and other legal material may be borrowed from the San Francisco Law Library for use within the City and County of San Francisco, for the periods of time and on the conditions hereinafter provided, by the judges of all courts situated within the City and County, by Municipal, State and Federal officers, and any member of the State Bar in good standing and practicing law in the City and County of San Francisco. Each book or other item so borrowed shall be returned within five days or such shorter period as the Librarian shall require for books of special character, including books constantly in use, or of unusual value. The Librarian may, in his discretion, grant such renewals and extensions of time for the return of books as he may deem proper under the particular circumstances and to the best interests of the Library and its patrons. Books shall not be borrowed or withdrawn from the Library by the general public or by law students except in unusual cases of extenuating circumstances and within the discretion of the Librarian.

Rule 2a. No book or other item shall be removed or withdrawn from the Library by anyone for any purpose without first giving written receipt in such form as shall be prescribed and furnished for the purpose, failure of which shall be ground for suspension or denial of the privilege of the Library.

Rule 5a. No book or other material in the Library shall have the leaves folded down, or be marked, dog-eared, or otherwise soiled, defaced or injured, and any person violating this provision shall be liable for a sum not exceeding treble the cost of replacement of the book or other material so treated and may be denied the further privilege of the Library.





Digitized by the Internet Archive  
in 2010 with funding from  
Public.Resource.Org and Law.Gov





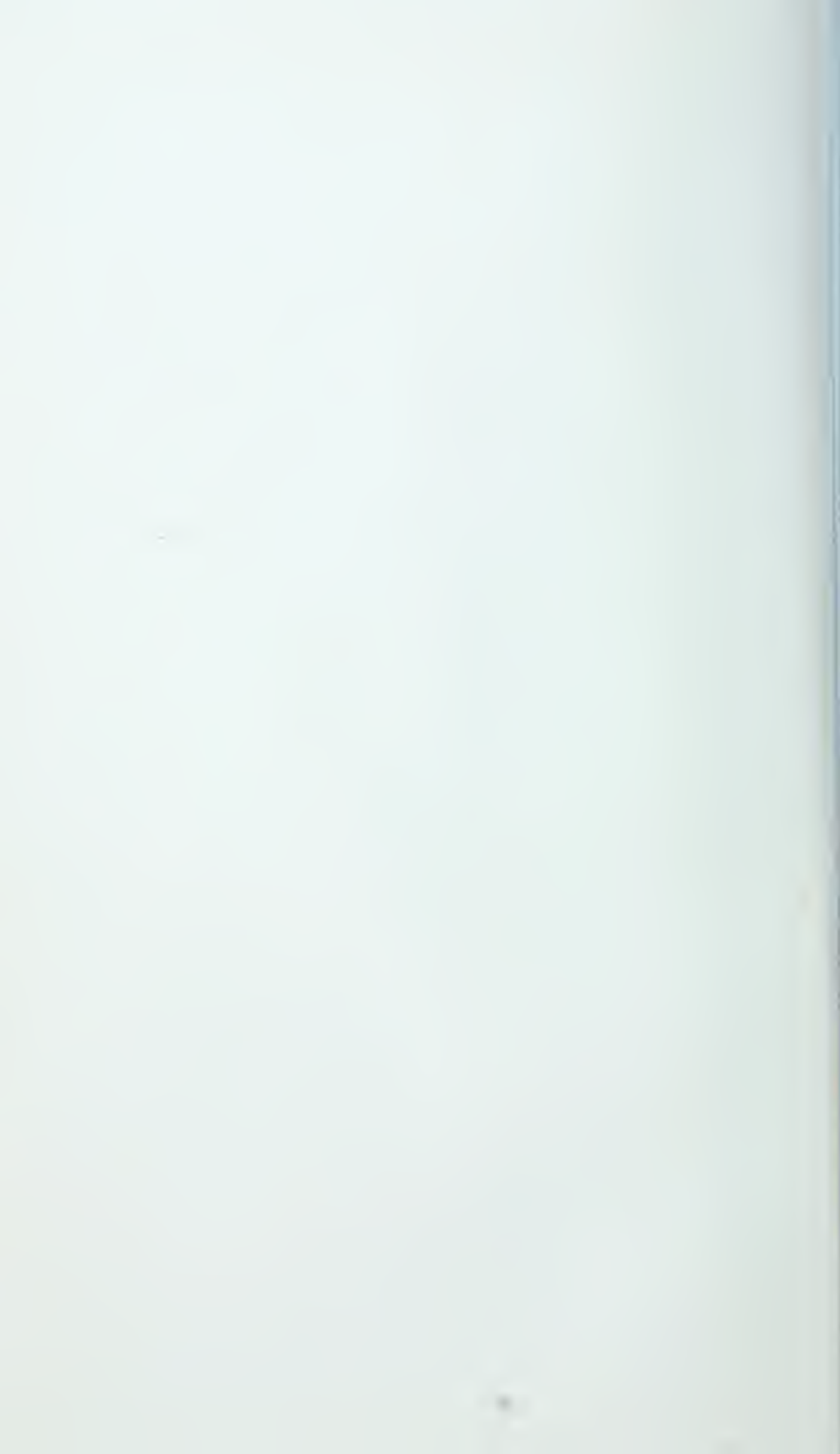



3024  
No. 15418

---

United States  
Court of Appeals  
for the Ninth Circuit

---

BERNARD H. STAUFFER, Appellant,

vs.

SLENDERELLA SYSTEMS OF CALIFORNIA,  
INC., a corporation, Appellee.

---

Transcript of Record

In Two Volumes

VOLUME I.

(Pages 1 to 389, inclusive)

---

Appeal from the United States District Court for the  
Southern District of California,  
Central Division

FILED

APR 18 1957

PAUL P. O'DWYER, CLERK



No. 15418

---

---

United States  
Court of Appeals  
for the Ninth Circuit

---

BERNARD H. STAUFFER, Appellant,

vs.

SLENDERELLA SYSTEMS OF CALIFORNIA,  
INC., a corporation, Appellee.

---

Transcript of Record

In Two Volumes

VOLUME I.

(Pages I to 389, inclusive)

---

Appeal from the United States District Court for the  
Southern District of California,  
Central Division

---

---





## INDEX

[Clerk's Note: When deemed likely to be of an important nature, errors or doubtful matters appearing in the original certified record are printed literally in italic; and, likewise, cancelled matter appearing in the original certified record is printed and cancelled herein accordingly. When possible, an omission from the text is indicated by printing in italic the two words between which the omission seems to occur.]

	PAGE
Answer and Counterclaims.....	5
Appeal:	
Certificate of Clerk to Transcript of Record on .....	57
Designation of Record on (Appellant's— USCA) .....	386
Designation of Record on (Appellee's— USCA) .....	389
Notice of .....	54
Statement of Points on (USCA).....	383
Supplemental Designation of Record on (Ap- pellant's—USCA) .....	388
Bill of Costs and Disbursements, Defendant's, Notice of and.....	51
Certificate of Clerk to Transcript of Record...	57
Complaint .....	3
Designation of Record (USCA):	
Appellant's .....	386
Appellant's Supplemental .....	388
Appellee's .....	389

Findings of Fact, Conclusions of Law and Judgment .....	48
First Request for Admissions and Plaintiff's Replies Thereto .....	33
Interrogatories Propounded to Defendant and Answers Thereto .....	28
Supplemental Answer .....	32
Minutes of the Court:	
Oct. 3, 1955 — Hearing on Motion to Add Party, etc. ....	19
Nov. 13, 1956—Trial.....	41
Nov. 14, 1956—Trial.....	42
Nov. 15, 1956—Trial.....	43
Nov. 16, 1956—Trial.....	45
Nov. 19, 1956—Trial.....	46
Motion to Re-Tax Costs, Notice of and.....	53
Names and Addresses of Attorneys.....	1
Notice of Appeal.....	54
Order Granting Motion to Re-Tax Costs.....	56
Order That Additional Party Be Brought In..	19
Reply to Counterclaim, Stauffer Systems, Inc.	28
Reply to Counterclaims, Bernard H. Stauffer and Stauffer System, Inc.....	21
Reply to Defendant's Second Request for Ad- missions .....	41

iii.

Request for Admissions, and Replies Thereto, Defendant's First .....	33
Second Request of Defendant for Admissions..	40
Statement of Points on Appeal (USCA).....	383
Supplementary Affidavit re Defendant's Bill of Costs and Disbursements.....	55
Supplemental Answer to Plaintiff's Interroga- tories .....	32
Transcript of Proceedings and Testimony.....	59
Closing Argument by Mr. Harris.....	363
Closing Argument by Mr. Lyon.....	356, 376
Exhibits for Plaintiff:	
1—Patent in Suit No. 2,240,679.....	391
Admitted in Evidence.....	73
15—Stauffer System Inc. - Mack et al. Agreement of Sept. 25, 1953.....	397
Admitted in Evidence.....	134
Exhibits for Defendant:	
B-1—File Wrapper and Contents of Stauf- fer Patent in Suit No. 2,240,679.....	399-443
Admitted in Evidence.....	191
D—Prior Art Patents.....	445-468
1—Parker Patent No. 1,978,223.....	446
2—Miller Patent No. 1,953,424.....	451
3—Gunderman Patent No. 1,825,588....	462
Admitted in Evidence.....	256

## Transcript of Proceedings—(Continued):

## Exhibits for Defendant—(Continued):

L—File Wrapper References Considered	
by U. S. Patent Office.....	469-502
1—Taylor Patent No. 86,604.....	470
2—Hardy Patent No. 1,276,526 .....	473
3—Hardy Patent No. 1,391,893.....	477
4—Iverson Patent No. 1,602,196.....	482
5—Rosenquist Patent No. 1,616,065.....	488
6—Torrence Patent No. 1,910,135.....	491
7—Hardy Patent No. 1,999,412.....	496
8—Snyder Patent No. 2,036,371.....	500
Admitted in Evidence.....	293
Opening Statement by Mr. Harris.....	62
Opinion of the Court.....	380
Witnesses:	
Fishbein, William I.	
—direct .....	294
—cross .....	306
Knapp, Robert T.	
—direct .....	197, 256
—cross .....	267
Nickerson, Douglas B.	
—direct .....	167
—cross .....	175
—redirect .....	189
Stauffer, Bernard H. (Deposition)	
—Partial .....	319-326



## Transcript of Proceedings—(Continued):

## Witnesses—(Continued):

## Stauffer, Bernard H.

—direct .....	92, 122
—cross .....	134
—redirect .....	162
—recalled, direct .....	337, 348

## Weiner, Jay

—direct .....	74
---------------	----



## NAMES AND ADDRESSES OF ATTORNEYS

### Attorneys for Appellant:

LYON & LYON,  
CHARLES G. LYON,  
811 West Seventh Street,  
Los Angeles 17, California.

### Attorneys for Appellee:

HARRIS, KIECH, FOSTER & HARRIS,  
FORD HARRIS, JR.,  
DONALD C. RUSSELL,  
WALTON EUGENE TINSLEY,  
417 South Hill Street,  
Los Angeles 13, California.

NEWLIN, TACKABURY & JOHNSTON,  
HUDSON B. COX,  
1100 Roosevelt Bldg.,  
727 West Seventh Street,  
Los Angeles 17, California. [1] \*

---

\* Page numbers appearing at bottom of page of original Transcript of Record.





In The United States District Court, Southern  
District of California, Central Division

Civil Action No. 18254-T

BERNARD H. STAUFFER, Plaintiff,

vs.

SLENDERELLA SYSTEMS OF CALIFORNIA,  
INC., Defendant.

### COMPLAINT

Comes Now the plaintiff, Bernard H. Stauffer, for cause of action against the defendant, and alleges and avers as follows:

#### I.

Plaintiff, Bernard H. Stauffer, is a citizen of the United States, a resident of the City of Los Angeles, State of California.

#### II.

Defendant, Slenderella Systems of California, Inc., is a corporation organized and existing under and by virtue of the laws of the State of California and has a regular and established place of business and has committed some of the acts of infringement complained of herein at 610 South Broadway in [2] the City of Los Angeles, State of California.

#### III.

The jurisdiction of this Court arises under the patent laws of the United States.

## IV.

That upon May 6, 1941, Letters Patent of the United States No. 2,240,679 were duly and regularly issued to plaintiff for an invention in muscle relaxing machine and the plaintiff has been since said date and still is the owner of the entire right, title and interest in and to said invention and to said letters patent and the sole right to recover for infringement thereof.

## V.

That within the last six years in the southern district of California and elsewhere throughout the United States defendant has infringed said letters patent by manufacturing and using and selling muscle relaxing machines which constitute infringement thereof and defendant will continue such infringement unless restrained by this Honorable Court.

## VI.

That plaintiff has affixed to any and all muscle relaxing machines manufactured by plaintiff or with the license and consent of plaintiff a patent notice bearing said patent No. 2,240,679.

Wherefore, plaintiff prays: [3]

A. For a preliminary and perpetual injunction enjoining the defendant, its agents, servants, employees and those acting in concert therewith from infringing said letters patent;

B. For an accounting of damages for said infringement;

C. For its costs and disbursements incurred herein including a reasonable attorney's fees;

D. For such other and further relief as to the Court may seem just.

LYON & LYON,

/s/ By CHARLES G. LYON,  
Attorneys for Plaintiff. [4]

[Endorsed]: Filed May 27, 1955.

---

In The United States District Court, Southern  
District of California, Central Division

Civil Action No. 18,254-T

BERNARD H. STAUFFER, Plaintiff,

vs.

SLENDERELLA SYSTEMS OF CALIFORNIA,  
INC., Defendant.

vs.

STAUFFER SYSTEM, INC.,  
Counter-Defendant.

### ANSWER AND COUNTERCLAIMS

The defendant in the above-entitled action answers the Complaint therein as follows:

1.

Defendant admits the averments of Paragraph I of the Complaint. [5]

## 2.

Answering Paragraph II of the Complaint, defendant denies that it has committed any acts in infringement of Letters Patent No. 2,240,679 in suit at 610 South Broadway, Los Angeles, California, or elsewhere, but admits all of the other averments thereof.

## 3.

Defendant admits the averments of Paragraph III of the Complaint.

## 4.

Answering Paragraph IV of the Complaint, defendant admits that upon May 6, 1941, Letters Patent of the United States No. 2,240,679 were issued to plaintiff for an alleged invention in muscle relaxing machine, denies that said Letters Patent were duly or regularly issued, and states that it is without knowledge or information sufficient to form a belief as to the truth of the remaining averments thereof.

## 5.

Defendant denies each and every averment of Paragraph V of the Complaint.

## 6.

Defendant is without knowledge or information sufficient to form a belief as to the truth of any averment of Paragraph VI of the Complaint. [6]

As Affirmative Defenses to the Complaint, Defendant Avers As Follows:

7.

The defendant has not infringed Letters Patent No. 2,240,679 in suit or any claim thereof.

8.

All of the claims of Letters Patent No. 2,240,679 in suit are invalid because the alleged inventions or discoveries described thereby were patented or disclosed in United States Letters Patent No. 1,978,223, issued to T. M. Parker on October 23, 1934.

9.

All of the claims of Letters Patent No. 2,240,679 in suit are invalid because they fail to comply with Section 112 of Title 35, United States Code, in particular, in failing to particularly point out and distinctly claim the parts, improvements, and combinations alleged to constitute the inventions or discoveries of said Letters Patent.

10.

All of the claims of Letters Patent No. 2,240,679 in suit are invalid because, in view of the state of the art as it existed at the time of, and long prior to, the date of the alleged inventions or discoveries claimed in said Letters Patent, said Letters Patent do not claim any invention or discovery, and do not involve any invention or discovery or contain any patentable novelty, but consist of the mere adoption of well-known devices for the required uses involving only the ordinary faculties of reasoning and skill of a mechanic skilled in the art to which said Letters Patent pertains. [7]

## 11.

All of the claims of Letters Patent No. 2,240,679 are invalid because each thereof defines merely an old combination of old elements each of which operates in substantially the same way to produce the same result in the device of said Letters Patent as they did individually in the prior art.

## 12.

While the application for Letters Patent No. 2,240,679 in suit was pending in the United States Patent Office the applicant therefor so limited and confined the claims of said application, under the requirements of the Commissioner of Patents, that plaintiff cannot now seek or obtain a construction of any of the claims of said Letters Patent sufficiently broad to cover any device manufactured, used, or sold by the defendant.

## 13.

All of the claims of Letters Patent No. 2,240,679 in suit are invalid because they cover subject matter not included in the original application as filed for said Letters Patent in suit and are not supported by any oath as required by Section 115, Title 35, United States Code.

## 14.

Plaintiff is barred from maintaining this action because of misuse of Letters Patent No. 2,240,679 in suit by reason of the following facts and otherwise: (a) plaintiff has licensed the use of apparatus covered by said Letters Patent only upon the condition that the licensee charge prices for such use as fixed



and determined by plaintiff in [8] the following language: "8. The Licensor [plaintiff] will furnish the Licensee with a written schedule of prices to be charged customers for the Stauffer System treatments, and the Licensee agrees at all times to maintain the said written price schedule as furnished by the Licensor."; (b) plaintiff has licensed the use of apparatus covered by said Letters Patent only upon the condition that the licensee purchase unpatented supplies and equipment from plaintiff in the following language: "12. As a part consideration in granting the Licensee this exclusive franchise, the Licensee agrees to use Stauffer Tables and Stauffer Equipment and Products exclusively, and to purchase, rent, or obtain same solely through the Licensor [plaintiff]. Licensee agrees not to sell or deal in any product or products, or permit the use of any products within any salon established under the terms of this agreement, except such as are manufactured or endorsed by the Licensor."; (c) plaintiff has licensed the use of apparatus covered by said Letters Patent only upon the condition that upon termination of the license the licensee shall thereafter refrain for a period of two (2) years from using certain unpatented business methods known as the "Stauffer System" in the following language: "23. In the event of the termination of this agreement for any reason, the Licensee agrees not to engage in any business predicated upon the principle of the Stauffer System, within the boundaries of the United States for a period of two (2) years after such termination, either directly or

indirectly.”; and (d) upon information and belief plaintiff has given Stauffer System, Inc., a California corporation, the right to grant licenses or sub-licenses under said Letters Patent to use the apparatus covered thereby and said Stauffer System, Inc. has granted such licenses or sub-licenses on the same [9] restrictive terms and conditions as set forth in (a), (b), and (c) above.

## 15.

Plaintiff cannot maintain this action because of the lack of an indispensable party, to-wit, said Stauffer System, Inc., which, upon information and belief, is the exclusive licensee under Letters Patent No. 2,240,679 in suit.

## 15a.

Plaintiff, on or about September 25, 1953, by remise and release, released and forever discharged the defendant from all manner of actions, causes, and causes of action, \* \* \* claims and demands, whatsoever, in law or in equity, theretofore existing in favor of the plaintiff, and the action herein falls within the scope of the said release.

As a First Counterclaim Against Plaintiff, Defendant Avers As Follows:

## 16.

Defendant is a California corporation having a regular and established place of business at Los Angeles, California.



17.

Plaintiff is a citizen of the State of California and resides at Los Angeles, California.

18.

Stauffer System, Inc., is a California corporation having a regular and established place of business at Los Angeles, California. [10]

19.

This counterclaim arises under Sections 2201 and 1338 of Title 28, United States Code, because there is an actual controversy now existing between defendant and plaintiff and Stauffer System, Inc., in respect to which defendant requires a declaration of its rights by this Court, which controversy involves the validity of Letters Patent No. 2,240,679 in suit and its alleged infringement by defendant, which Letters Patent is alleged by plaintiff to be owned by him and infringed by defendant.

20.

Defendant adopts and repeats the averments of Paragraphs 7 to 14, inclusive, set forth above.

21.

Defendant alleges upon information and belief that Stauffer System, Inc., is the exclusive licensee under Letters Patent No. 2,240,679 in suit, and prays leave and permission to amend this counterclaim to add said Stauffer System, Inc., as a party hereto.

As a Second Counterclaim against Plaintiff, Defendant Avers As Follows:

indirectly.”; and (d) upon information and belief plaintiff has given Stauffer System, Inc., a California corporation, the right to grant licenses or sub-licenses under said Letters Patent to use the apparatus covered thereby and said Stauffer System, Inc. has granted such licenses or sub-licenses on the same [9] restrictive terms and conditions as set forth in (a), (b), and (c) above.

15.

Plaintiff cannot maintain this action because of the lack of an indispensable party, to-wit, said Stauffer System, Inc., which, upon information and belief, is the exclusive licensee under Letters Patent No. 2,240,679 in suit.

15a.

Plaintiff, on or about September 25, 1953, by remise and release, released and forever discharged the defendant from all manner of actions, causes, and causes of action, \* \* \* claims and demands, whatsoever, in law or in equity, theretofore existing in favor of the plaintiff, and the action herein falls within the scope of the said release.

As a First Counterclaim Against Plaintiff, Defendant Avers As Follows:

16.

Defendant is a California corporation having a regular and established place of business at Los Angeles, California.

17.

Plaintiff is a citizen of the State of California and resides at Los Angeles, California.

18.

Stauffer System, Inc., is a California corporation having a regular and established place of business at Los Angeles, California. [10]

19.

This counterclaim arises under Sections 2201 and 1338 of Title 28, United States Code, because there is an actual controversy now existing between defendant and plaintiff and Stauffer System, Inc., in respect to which defendant requires a declaration of its rights by this Court, which controversy involves the validity of Letters Patent No. 2,240,679 in suit and its alleged infringement by defendant, which Letters Patent is alleged by plaintiff to be owned by him and infringed by defendant.

20.

Defendant adopts and repeats the averments of Paragraphs 7 to 14, inclusive, set forth above.

21.

Defendant alleges upon information and belief that Stauffer System, Inc., is the exclusive licensee under Letters Patent No. 2,240,679 in suit, and prays leave and permission to amend this counterclaim to add said Stauffer System, Inc., as a party hereto.

As a Second Counterclaim against Plaintiff, Defendant Avers As Follows:

## 22. Parties

Defendant adopts and repeats the averments of Paragraphs 16, 17 and 18 set forth above.

## 23.

Defendant alleges upon information and belief [11] that Stauffer System, Inc. is the exclusive licensee under Letters Patent No. 2,240,679 in suit, and prays leave and permission to amend this counterclaim to add said Stauffer System, Inc., as a party hereto.

## 24. Jurisdiction

Jurisdiction for this Counterclaim arises under Sections 1, 2, 4, 14, 15, and 26, Title 15, United States Code, commonly known as the Sherman Act.

## 25.

Commencing in the year 1939, plaintiff Stauffer began to manufacture and deliver to users muscle relaxing machines covered by Letters Patent No. 2,240,679 in suit, hereinafter referred to as "Stauffer Tables," and continued to do so until about 1947, during such period delivering large numbers thereof in the State of California and throughout the United States. Such Stauffer Tables have been sold and shipped by plaintiff in interstate commerce to licensees located in states other than the state where the same are manufactured. Some of said Stauffer Tables so delivered were sold outright by plaintiff but as to most of them plaintiff retained title thereto. In connection with such deliveries, plaintiff licensed the use of the Stauffer Tables so delivered by written agreements entered into with

the recipients thereof. Under the terms of many of such agreements, and as a condition to the grant of such licenses, the plaintiff required the licensees to agree to charge prices for the use of such Stauffer Tables as fixed and determined by the plaintiff, required the licensees to purchase unpatented supplies and equipment from plaintiff, required that upon termination of such agreements [12] the licensees refrain from the use of certain unpatented business methods known as the "Stauffer System," and required that during the term of the license the licensees refrain from using any apparatus competitive with Stauffer Tables, all as specifically set forth in Paragraph 14 above.

26.

Stauffer System, Inc., a California corporation, was organized in or about 1947 by plaintiff Stauffer to carry on the business of manufacturing, using, and licensing the use of Stauffer Tables theretofore conducted by the plaintiff Stauffer personally. Upon information and belief, in or about 1947 the plaintiff Stauffer granted to said Stauffer System, Inc. the right to make and rent Stauffer Tables and to grant licenses and sub-licenses under said Letters Patent No. 2,240,679 in suit, and said Stauffer System, Inc. has until the present continued such business in substantially the same manner as set forth in Paragraph 25 above.

27.

Commencing in 1939 the plaintiff Stauffer, and since 1947, the plaintiff and said Stauffer System,



Inc. have restrained trade and commerce among the several states by reason of said licenses aforesaid and otherwise, and have combined and conspired to restrain unreasonably the aforesaid trade and commerce in violation of Section 1 of the Sherman Act; have combined and conspired together to monopolize the aforesaid trade and commerce in violation of Section 2 of the Sherman Act; have attempted to monopolize the aforesaid trade and commerce in violation of Section 2 of the Sherman Act; have monopolized the aforesaid trade and commerce in violation [13] of Section 2 of the Sherman Act and have leased and sold goods, wares, merchandise, machinery, supplies, and other commodities, and fixed prices therefor, on the condition that the lessee or purchaser thereof shall not use or deal in the goods, wares, merchandise, machinery, supplies, and other commodities of competitors of plaintiff, and the effect thereof has been to substantially lessen competition and tend to create a monopoly in the line of commerce to which business of the plaintiff and Stauffer System, Inc. pertains, in violation of Section 14 of the Sherman Act. The substantial terms of the aforesaid combinations and conspiracies and the means and methods of the attempt to monopolize and monopolization have been:

(a) That the plaintiff alone, and in combination with Stauffer System, Inc. would obtain a monopoly of the business relating to the use of muscle relaxing machines and unpatented supplies and equipment used in connection therewith.

(b) That the plaintiff and said Stauffer System,

Inc. would exclude others from the manufacture, use, and sale of such muscle relaxing machines.

(c) That the plaintiff and Stauffer System, Inc. would threaten to bring and would bring suits for infringement of said Letters Patent No. 2,240,679 for the purpose of discouraging others from manufacturing and selling other muscle relaxing machines and using the same.

(d) That the plaintiff and Stauffer System, Inc. would eliminate and suppress competition between themselves and their licensees by requiring such licensees to adhere to prices fixed by plaintiff and/or Stauffer System, Inc. and to be charged by the licensees for the use of such machines. [14]

(e) That the plaintiff and Stauffer System, Inc. would lessen competition and tend to create a monopoly in their said business by requiring that licensees and purchasers of Stauffer Tables refrain from purchasing or selling unpatented goods, wares, merchandise, machinery, supplies, and other commodities obtained from competitors of plaintiff and Stauffer System, Inc.

28.

The bringing of this patent infringement action by the plaintiff was in furtherance of the unlawful combinations, conspiracies, attempt to monopolize, and monopoly aforesaid and part and parcel thereof.

29.

The aforesaid attempt to monopolize and monopolization and combinations and conspiracies have had the following effects:

(a) The plaintiff and Stauffer System, Inc. have obtained a monopoly of the use of said muscle relaxing machines.

(b) The plaintiff and Stauffer System, Inc. have unreasonably restrained interstate trade and commerce in unpatented supplies and equipment used by their licensees in connection with said muscle relaxing machines.

(c) Competition in the sale and use of muscle relaxing machines has been substantially lessened and there has been a tendency to create a monopoly in plaintiff and Stauffer System, Inc. in connection therewith.

(d) Competition in the sale of unpatented [15] products used and sold in connection with the use of muscle relaxing machines has been substantially lessened and there has been a tendency to create a monopoly in plaintiff and Stauffer System, Inc., in connection therewith.

(e) Defendant has been injured in its business and property to an extent not as yet fully ascertained by the defendant, which prays leave to insert the monetary sum of its damages by appropriate amendment or pleading herein when ascertained.

Wherefore, the defendant and counterclaimant prays as follows:

1. That the Complaint be dismissed with prejudice;
2. That United States Letters Patent No. 2,240,-679, and each and every claim thereof, be adjudged invalid, void, and unenforceable;
3. That United States Letters Patent No. 2,240,-



679, and each and every claim thereof, be adjudged not infringed by any act of defendant;

4. That the combinations and conspiracies in restraint of trade and commerce, the combination and conspiracy to monopolize, the attempt to monopolize and the monopoly charged herein be adjudged and decreed to be unlawful, and that the agreements, contracts, and practices of plaintiff and Stauffer System, Inc. alleged herein be adjudged and decreed to be in violation of Sections 1, 2, and 14 of the Sherman Act;

5. That the Court adjudge and decree that plaintiff and Stauffer System, Inc. have combined to restrain trade and commerce in violation of Section 1 of the Sherman Act; [16]

6. That the Court adjudge and decree that the plaintiff and Stauffer System, Inc., and each of them, have monopolized, attempted to monopolize and combined and conspired to monopolize trade and commerce in violation of Section 2 of the Sherman Act;

7. That the Court adjudge and decree that the plaintiff and Stauffer System, Inc., and each of them, have lessened competition and tended to create a monopoly in violation of Section 14 of the Sherman Act;

8. That the Court adjudge and decree that the plaintiff and Stauffer System, Inc., and each of them, have used said Letters Patent No. 2,240,679 unlawfully in instituting, effectuating, and maintaining the aforesaid offenses;

9. That the Court issue a permanent injunction against the plaintiff, Stauffer System, Inc., their

(a) The plaintiff and Stauffer System, Inc. have obtained a monopoly of the use of said muscle relaxing machines.

(b) The plaintiff and Stauffer System, Inc. have unreasonably restrained interstate trade and commerce in unpatented supplies and equipment used by their licensees in connection with said muscle relaxing machines.

(c) Competition in the sale and use of muscle relaxing machines has been substantially lessened and there has been a tendency to create a monopoly in plaintiff and Stauffer System, Inc. in connection therewith.

(d) Competition in the sale of unpatented [15] products used and sold in connection with the use of muscle relaxing machines has been substantially lessened and there has been a tendency to create a monopoly in plaintiff and Stauffer System, Inc., in connection therewith.

(e) Defendant has been injured in its business and property to an extent not as yet fully ascertained by the defendant, which prays leave to insert the monetary sum of its damages by appropriate amendment or pleading herein when ascertained.

Wherefore, the defendant and counterclaimant prays as follows:

1. That the Complaint be dismissed with prejudice;
2. That United States Letters Patent No. 2,240,-679, and each and every claim thereof, be adjudged invalid, void, and unenforceable;
3. That United States Letters Patent No. 2,240,-

679, and each and every claim thereof, be adjudged not infringed by any act of defendant;

4. That the combinations and conspiracies in restraint of trade and commerce, the combination and conspiracy to monopolize, the attempt to monopolize and the monopoly charged herein be adjudged and decreed to be unlawful, and that the agreements, contracts, and practices of plaintiff and Stauffer System, Inc. alleged herein be adjudged and decreed to be in violation of Sections 1, 2, and 14 of the Sherman Act;

5. That the Court adjudge and decree that plaintiff and Stauffer System, Inc. have combined to restrain trade and commerce in violation of Section 1 of the Sherman Act; [16]

6. That the Court adjudge and decree that the plaintiff and Stauffer System, Inc., and each of them, have monopolized, attempted to monopolize and combined and conspired to monopolize trade and commerce in violation of Section 2 of the Sherman Act;

7. That the Court adjudge and decree that the plaintiff and Stauffer System, Inc., and each of them, have lessened competition and tended to create a monopoly in violation of Section 14 of the Sherman Act;

8. That the Court adjudge and decree that the plaintiff and Stauffer System, Inc., and each of them, have used said Letters Patent No. 2,240,679 unlawfully in instituting, effectuating, and maintaining the aforesaid offenses;

9. That the Court issue a permanent injunction against the plaintiff, Stauffer System, Inc., their

officers, agents, employees, and attorneys, enjoining them, and each of them, and all those in active concert or privity or participating with them, from further violations of Title 15, United States Code as alleged herein;

10. That defendant have and recover from plaintiff and Stauffer System, Inc., its costs and a reasonable attorneys' fee in this action, as provided for by Section 285, Title 35, United States Code;

11. That defendant have and recover from plaintiff and Stauffer System, Inc. on its second counterclaim defendant's actual damages, and that the Court enter judgment thereon the amount of three-fold the actual damages sustained, as provided for by Section 15, Title 15, United States Code, and that defendant have and recover from plaintiff and Stauffer System, Inc. defendant's costs and attorneys' fees as provided in such statute; [17]

12. That defendant be granted such other and further relief as the Court may deem proper.

Dated: August 4, 1955.

NEWLIN, HOLLEY, TACKABURY  
& JOHNSTON,  
HUDSON B. COX,  
HARRIS, KIECH, FOSTER &  
HARRIS,  
FORD HARRIS, JR.,  
DONALD C. RUSSELL,

/s/ By DONALD C. RUSSELL

Attorneys for Defendant. [18]

Acknowledgment of Receipt of Copy Attached.  
[Endorsed]: Filed Aug. 4, 1955.

[Title of District Court and Cause.]

MINUTES OF THE COURT

Date: Oct. 3, 1955, at Los Angeles, Calif.

Present: Hon. Ernest A. Tolin, District Judge.

Deputy Clerk: Wm. A. White; Reporter: Virginia Wright.

Counsel for Plaintiff: Chas. G. Lyon; Counsel for Defendant: Donald C. Russell and Hudson B. Cox.

Proceedings: For hearing on Defendant's motion for order granting Defendant leave to add Stauffer System, Inc., as a party to the action; for leave to add Stauffer System, Inc., as counter-defendant to "Answer and Counterclaims"; for leave to file and serve third-party complaint; for order granting leave to file amended answer and counterclaims including cross-complaint against Stauffer Systems, etc.

It Is Ordered that motion to bring in Stauffer System, Inc., as a party to the action is granted.

Attorney for defendant is directed to prepare formal order.

JOHN A. CHILDRESS,  
Clerk [20]

---

[Title of District Court and Cause.]

ORDER THAT ADDITIONAL PARTY  
BE BROUGHT IN

The motion of defendant Slenderella Systems of California, Inc. to add Stauffer System, Inc., a



California corporation, as a party to the above entitled action having come on regularly to be heard in the above entitled court, the Honorable Ernest A. Tolin, Judge, presiding, on the 3rd day of October, 1955, plaintiff Bernard H. Stauffer being represented by Messrs. Lyon & Lyon by Charles G. Lyon, Esquire, and defendant Slenderella Systems of California, Inc. being represented by Messrs. Harris, Kiech, Foster & Harris by Donald C. Russell, Esquire, and by Messrs. Newlin, Holley, Taackbury & Johnston by Hudson B. Cox, Esquire, and the Court having considered the memorandum filed in support of and in opposition to said motion, and the Court being fully advised in the premises, finds that the addition of Stauffer System, Inc. as a party to said action [21] is required for the granting of complete relief in the determination of the counterclaims of defendant Slenderella Systems of California, Inc.; the Court further finds that jurisdiction over said Stauffer System, Inc. can be obtained and that its joinder will not deprive the Court of jurisdiction of the action.

It Is Therefore Ordered:

1. That Stauffer System, Inc. be added as a party counter-defendant to the counterclaims of defendant Slenderella Systems of California, Inc. herein pursuant to Rule 13 (h) of the Federal Rules of Civil Procedure;

2. That the Clerk of this Court be and he hereby is authorized and directed to amend by interlineation the caption of the answer and counterclaims of defendant Slenderella Systems of California, Inc.

to add Stauffer System, Inc. as a counter-defendant to said counterclaims; and

3. That the Clerk of this Court be and he hereby is authorized and directed to issue under the seal of this Court an alias summons directed to Stauffer System, Inc. requiring it to appear and answer or otherwise plead to the counterclaims of defendant Slenderella Systems of California, Inc. in the above entitled action.

Dated, October 5, 1955.

/s/ ERNEST A. TOLIN,

United States District Judge

Approved as to form.

/s/ CHARLES G. LYON,

LYON & LYON,

Attorneys for Plaintiff [22]

[Endorsed]: Filed Oct. 6, 1955.

---

[Title of District Court and Cause.]

## REPLY TO COUNTERCLAIMS

Come now the plaintiff, Bernard H. Stauffer and Stauffer System, Inc., counter-defendants, and in reply to the counterclaims herein aver, allege and deny as follows:

### I.

Answering Paragraphs 16 and 17 of said counterclaims, counter-defendants admit the allegations contained therein.

### II.

Answering Paragraph 18 of said counterclaims, counter-defendants deny each and every allegation

contained therein and allege that Stauffer System, Inc., a California corporation, was duly wound up and dissolved in May of 1952. [23]

### III.

Answering Paragraph 19 of said counterclaims, counter-defendants admit that a controversy exists between defendant and plaintiff involving the validity of Letters Patent No. 2,240,679 in suit and infringement thereof by defendant. Further answering said paragraph, counter-defendants deny that there is any controversy between defendant and Stauffer System, Inc., a defunct corporation.

### IV.

Answering Paragraph 20 of said counterclaim, counter-defendants deny each and every allegation contained in Paragraphs 7, 8, 9, 10, 11, 12 and 13 of defendant's answer. Further answering said paragraph, and particularly answering Paragraph 14 of defendant's answer, counter-defendants deny that they are barred from maintaining this action because of any misuse of Patent No. 2,240,679. Further answering said paragraph, and particularly Paragraph 14 of said answer, counter-defendants deny that at any time relevant to this controversy any license granted by plaintiff for the use of the apparatus covered by the Letters Patent in suit contain any of the provisions set forth under sections (a) or (b) of said Paragraph 14. With respect to section (c) of said Paragraph 14, counter-defendants admit that franchises for the use of the Stauffer system contain language substantially to



the same effect as that alleged by defendant at lines 22-27 of Page 5 of defendant's answer and counterclaims. Counter-defendants deny that such franchises constitute a misuse of the patent in suit, and further allege that Stauffer system franchises have been granted in every state in the union under a uniform franchise agreement, and that in some states of the union at least the provision of said agreement quoted in Section (c) of defendant's answer and counterclaims is wholly legal and proper and that in such states of the union under which said [24] agreement is illegal that the same is wholly void and therefore governed by the provisions in said franchise agreement reading as follows:

“If any of the provisions of this agreement are held to be contrary to law and unenforceable, such holding shall not affect or invalidate the other parts of this agreement, and such invalid or unenforceable part shall be deemed separable from the remainder of this agreement.”

Further answering Paragraph 14 of said answer, counter-defendants allege that insofar as the provision quoted in section (c) of said paragraph is illegal, it has at no time been enforced by counter-defendants or either of them and that **plaintiff** Stauffer does not intend to attempt to enforce said provision wherever it is illegal and specifically waives his right to so do.

## V.

Answering Paragraph 21 of said counterclaims,

such holding shall not affect or invalidate the other parts of this agreement, and such invalid or unenforceable part shall be deemed separable from the remainder of this agreement.”

Further answering said paragraph, counter-defendants allege that insofar as the provision quoted in section (c) of said paragraph is illegal it has at no time been enforced by counter-defendants or either of them and that plaintiff Stauffer does not intend to attempt to enforce said provision wherever it is illegal and specifically waives his right to so do.

#### X.

Answering Paragraph 26 of said counterclaims, counter-defendants admit that from 1947 to 1952 the business of the Stauffer system was carried on by Stauffer System, Inc., but further allege that said Stauffer System, Inc. was duly wound up and dissolved as of May, 1952. Further answering said paragraph, counter-defendants admit that during the period 1947-1952, Stauffer System, Inc. was granted the right to make and rent and grant licenses and sublicenses under said Letters Patent No. 2,240,679. Further answering said paragraph, counter-defendants deny each and every other allegation contained therein.

#### XI.

Answering Paragraph 27 of said counterclaims, counter-defendants [27] deny each and every allegation contained therein.

XII.

Answering Paragraph 28 of said counterclaims, counter-defendants deny each and every allegation contained therein.

XIII.

Answering Paragraph 29 of said counterclaims, counter-defendants deny each and every allegation contained therein.

XIV.

Further answering said counterclaims, and each of them, and as a separate and complete defense thereto, counter-defendants allege that said alleged counterclaims and each of them are barred by the provisions of sub-division 1 of Section 338 of the Code of Civil Procedure of the State of California.

Wherefore, counter-defendants pray that the counterclaims of defendant herein be dismissed, and that the defendants take nothing thereby, and that counter-defendants recover from defendant their costs and disbursements herein including reasonable attorneys' fees.

Dated this 12th day of October, 1955.

LYON & LYON,

/s/ By CHARLES G. LYON,

Attorney for Counter-  
Defendants [28]

Acknowledgment of Service attached. [29]

[Endorsed]: Filed Oct. 12, 1955.

[Title of District Court and Cause.]

### REPLY TO COUNTERCLAIM

Comes now the counter-defendant, Stauffer Systems, Inc. and in reply to the counterclaims herein hereby adopts the reply thereto filed October 12, 1955, by Bernard H. Stauffer at its reply to said counterclaims.

Dated at Los Angeles, California this 16th day of February, 1956.

STAUFFER SYSTEMS, INC.,  
 Counter-Defendant,  
 By LYON & LYON,  
 /s/ By CHARLES G. LYON,  
 Attorneys for Counter-  
 Defendant [34]

Acknowledgment of Service attached. [35]

[Endorsed]: Filed Feb. 17, 1956.

[Title of District Court and Cause.]

### INTERROGATORIES PROPOUNDED TO DEFENDANT AND ANSWERS THERETO

Comes now the plaintiff and propounds the following interrogatories to be answered by an officer of the defendant under oath in accordance with Rule 33 of the Rules of Civil Procedure:

Interrogatory No. I:

“Has defendant at any time since September 25, 1953

- a) manufactured
- b) used
- c) sold or leased

a table adapted to support a human body, having a horizontally extending slot in which is mounted a movable pad?"

Comes now defendant Slenderella Systems of California, Inc. and answers the interrogatories propounded to said defendant as follows: [36]

Answer to Interrogatory No. 1:

Defendant has used but has not manufactured, sold or leased a table approximately as described in said interrogatory, except that the movable pad referred to is not mounted in a slot, but rather over a slot.

Interrogatory No. II:

"If the answer to Interrogatory I is in the affirmative, has defendant during said time manufactured, used, sold or leased more than one type of such table?"

Answer to Interrogatory No. II:

No.

Interrogatory No. V:

"What relationship, if any, exists between defendant and

- a) Slenderella Systems of Illinois, Inc.
- b) Michigan Slenderella Systems, Inc.
- c) Slenderella Systems of Ohio, Inc.
- d) Slenderella Systems of Delaware, Inc.



- e) Evergreen Park Slenderella Systems, Inc.
- f) Blanchette-Mack, Inc.
- g) Any other corporation having as part of its corporate name the word Slenderella?"

Answer to Interrogatory No. V:

No relationship exists between this defendant and the corporations referred to other than the fact that Larry L. Mack, president of the above corporation, is also a stockholder of the other Slenderella corporations referred to. The stock of Blanchette-Mack, Inc. was purchased in part by this defendant pursuant to an arrangement under Chapter 11 of the Bankruptcy Act. [37]

Interrogatory No. VI:

"Does defendant distribute to its salons a manual of instructions for operating the Slenderella Systems?"

Answer to Interrogatory No. VI:

Yes.

Interrogatory No. VII:

"If the answer to Interrogatory I is in the affirmative, does defendant offer said tables for sale

- a) generally
- b) to holders of Stauffer Systems franchises?"

Answer to Interrogatory No. VII:

No.

Interrogatory No. VIII:

"How has defendant been damaged by reason of the facts alleged in paragraph 25 of its counterclaim?"

Answer to Interrogatory No. VIII:

Defendant knows of no specific damage but is ascertaining the facts.

Interrogatory No. IX:

“How has defendant been damaged by reason of the facts alleged in paragraph 26 of its counterclaim?”

Answer to Interrogatory No. IX:

Defendant claims no damage pursuant to this paragraph of its counterclaim.

Interrogatory No. X:

“How has defendant been damaged since September 25, 1953 by reason of the alleged fixing of prices charged by users of Stauffer tables?” [38]

Interrogatory No. XI:

“How has defendant been damaged by the alleged restrictions in Stauffer System licenses?”

Answers to Interrogatories Nos. X and XI:

Defendant now knows of no specific damage, but is ascertaining the facts.

Interrogatories dated Feb. 16, 1956 and signed by Bernard H. Stauffer, Plaintiff, by Lyon & Lyon, by Charles G. Lyon, Attorneys for Plaintiff.

Answers signed by Harris, Kiech, Foster & Harris and Newlin, Holley, Tackabury & Johnston, by Hudson B. Cox, Attorneys for Defendant and Counterclaimant, Slenderella Systems of California, Inc.

Answers Duly Verified. [39]

Affidavit of Service by Mail Attached. [40]

[Endorsed]: Interrogatories Filed Feb. 17, 1956.  
Answers Mar. 7, 1956.

[Title of District Court and Cause.]

SUPPLEMENTAL ANSWER TO PLAINTIFF'S INTERROGATORIES

To correct an error appearing in Answers to Plaintiff's Interrogatories executed March 5, 1956, and filed in the above action on or about March 8, 1956, defendant Slenderella Systems of California, Inc., hereby answers plaintiff's Interrogatory II as follows:

Interrogatory No. II:

"If the Answer to Interrogatory I is in the affirmative, has defendant during said time manufactured, used, sold or leased more than one type of such table?" [59]

Answer to Interrogatory No. II:

Yes.

HARRIS, KIECH, FOSTER &  
HARRIS and  
NEWLIN, TACKABURY &  
JOHNSTON,

/s/ By HUDSON B. COX,

Attorneys for Defendant and Counterclaimant,  
Slenderella Systems of California, Inc.

Duly Verified. [60]

Affidavit of Service by Mail attached. [61]

[Endorsed]: Filed Oct. 5, 1956.



[Title of District Court and Cause.]

DEFENDANT'S FIRST REQUEST FOR ADMISSIONS AND REPLIES THERETO

Pursuant to Rule 36 of the Rules of Civil Procedure, the defendant in the above-entitled action hereby requests that plaintiff within ten (10) days after service hereof admit in writing the following matters:

Request No. 1: The Franchise Agreement dated March 10, 1946, between B. H. Stauffer and Alvetta Decker, attached hereto as "Exhibit A," is a true copy of such an agreement of that date entered into by and between the parties named therein.

Comes now the plaintiff, Bernard H. Stauffer, and makes answer to the requests for admissions as follows:

Answer: Request No. 1 is admitted.

Request No. 2: The B. H. Stauffer named in said Exhibit A hereto is the plaintiff in this action.

Answer: Request No. 2 is admitted.

Request No. 3: Agreements identical with Exhibit A hereto, or to the printed matter set forth therein, have been entered into by plaintiff with others than said Alvetta Decker.

Answer: Request No. 3 is admitted. [62]

Request No. 4: One or more agreements identical with Exhibit A hereto, as to the printed matter set forth therein, between plaintiff and another or others, were in force and effect on June 2, 1955.

Answer: Request No. 4 is denied.

Request No. 5: One or more agreements identical with Exhibit A hereto, as to the printed matter set forth therein, between plaintiff and another or others, were in force and effect on September 20, 1956.

Answer: Request No. 5 is denied.

Request No. 6: The Franchise Agreement dated July 15, 1948, between Stauffer System, Inc. and Geraldine Scarborough and Juanita Scarborough Kerley, attached hereto as "Exhibit B," is a true copy of such an agreement of that date entered into by and between the parties named therein.

Answer: Request No. 6 is admitted.

Request No. 7: Agreements identical with Exhibit B hereto, as to the printed matter set forth therein, have been entered into by said Stauffer System, Inc. with another or others than said Geraldine Scarborough and Juanita Scarborough Kerley.

Answer: Request No. 7 is admitted.

Request No. 8: One or more agreements identical with Exhibit B hereto, as to the printed matter set forth therein, between said Stauffer System, Inc. and another or others, were in force and effect on June 2, 1955.

Answer: Request No. 8 is denied.

Request No. 9: One or more agreements identical with Exhibit B hereto, as to the printed matter set forth therein, between said Stauffer System, Inc. and another or others, were in force and effect on September 20, 1956.

Answer: Request No. 9 is denied.

Request No. 10: The Franchise Agreement dated November 1, [63] 1949, between Stauffer System, Inc. and Marie Smith, attached hereto as "Exhibit C," is a true copy of such an agreement of that date entered into by and between the parties named therein.

Answer: Request No. 10 is admitted.

Request No. 11: Agreements identical with Exhibit C hereto, as to the printed matter set forth therein, have been entered into by said Stauffer System, Inc. with another or others than said Marie Smith.

Answer: Request No. 11 is admitted.

Request No. 12: One or more agreements identical with Exhibit C hereto, as to the printed matter set forth therein, between said Stauffer System, Inc. and another or others, were in force and effect on June 2, 1955.

Answer: Request No. 12 is denied.

Request No. 13: One or more agreements identical with Exhibit C hereto, as to the printed matter set forth herein, between said Stauffer System, Inc. and another or others, were in force and effect on September 20, 1956.

Answer: Request No. 13 is denied.

Request No. 14: The blank printed form of Franchise Agreement attached hereto as "Exhibit D" is a form of agreement entered into by plaintiff and Sally A. Stauffer, doing business as a co-partnership, with another or others.

Answer: Request No. 14 is admitted.

Request No. 15: One or more agreements in the form exemplified by Exhibit D between plaintiff and said Sally A. Stauffer and another or others were in force and effect on June 2, 1955.

Answer: Request No. 15 is admitted.

Request No. 16: One or more agreements in the form exemplified by Exhibit D between plaintiff and said Sally A. Stauffer and another or others were in force and effect on September 20, 1956.

Answer: Request No. 16 is admitted. [64]

Request No. 17: The blank printed form of Franchise Agreement attached hereto as "Exhibit E" is a form of agreement entered into by plaintiff and Sally A. Stauffer, doing business as a co-partnership, with another or others.

Answer: Request No. 17 is admitted.

Request No. 18: One or more agreements in the form exemplified by Exhibit E between plaintiff and said Sally A. Stauffer and another or others were in force and effect on June 2, 1955.

Answer: Request No. 18 is admitted.

Request No. 19: One or more agreements in the form exemplified by Exhibit E between plaintiff and said Sally A. Stauffer and another or others were in force and effect on September 20, 1956.

Answer: Request No. 19 is admitted.

Request No. 20: On the date that the original Franchise Agreement exemplified by Exhibit A was executed, plaintiff had the right to grant licenses or sublicenses under United States Letters Patent No. 2,240,679 here in suit.

Answer: Request No. 20 is admitted.

Request No. 21: On the date when each of the agreements referred to in Requests 2 and 3, above, was executed, plaintiff had the right to grant licenses or sublicenses under said Letters Patent No. 2,240,679 here in suit.

Answer: Request No. 21 is admitted.

Request No. 22: On the date when each of the agreements referred to in Requests 6, 7, 10 and 11, above, was executed, said Stauffer System, Inc. had the right to grant licenses or sublicenses under said Letters Patent No. 2,240,679 here in suit.

Answer: Request No. 22 is admitted.

Request No. 23: On the date when each of the agreements referred to in Requests 14 and 17, above, was executed, plaintiff and/or said Sally A. Stauffer had the right to grant licenses or sublicenses under said Letters Patent No. 2,240,679 here in suit. [65]

Answer: Request No. 23 is admitted.

Request No. 24: In accordance with Paragraph 8 of Exhibit A hereto, plaintiff directly or indirectly furnished to said Alvetta Decker and/or others parties to similar agreements a written schedule of prices to be charged by them to their customers for "Stauffer System treatments."

Answer: Plaintiff admits that a suggested price list at one time was furnished to franchise holders but such prices were never complied with by the franchise holders or enforced by plaintiff, and such suggestion of prices was discontinued by plaintiff long prior to any time material to this case.

Request No. 25: In accordance with Paragraph



8 of Exhibit B hereto, plaintiff and/or said Stauffer System, Inc. directly or indirectly furnished to said Geraldine Scarborough and/or Juanita Scarborough Kerley and/or other parties to similar agreements a written schedule of prices to be charged by them to their customers for "Stauffer System treatments."

Answer: Plaintiff admits that a suggested price list at one time was furnished to franchise holders but such prices were never complied with by the franchise holders or enforced by plaintiff, and such suggestion of prices was discontinued by plaintiff long prior to any time material to this case.

Request No. 26: There was no substantial difference in mechanical construction or operation between the "Stauffer Tables," referred to in Exhibits A, B, C and E hereto, and the corresponding "Rith-Matic" tables, referred to in Exhibit D hereto.

Answer: Request No. 26 is admitted.

Request No. 27: The "Stauffer System" referred to in Exhibits A, B, C, D and E hereto included the use of four tables differing in construction and mode of operation, such tables being identified by plaintiff as tables No. 1, No. 2, No. 3, and No. 4.

Answer: Request No. 27 is admitted. [66]

Request No. 28: Plaintiff has sold to franchise holders who were parties to franchise agreements of the types exemplified by Exhibits A-E, inclusive, hereto, for resale by them to the public, an unpatented product bearing the name "Staufferettes."

Answer: Request No. 28 is admitted.

Request No. 29: Plaintiff has sold to franchise holders who were parties to franchise agreements of the types exemplified by Exhibits A-E, inclusive, hereto, for resale by them to the public, an unpatented product bearing the name "Skimps."

Answer: Request No. 29 is admitted.

Request No. 30: The only shareholders of said Stauffer System, Inc. since its formation and during its existence have been plaintiff, his wife, and his sister, the said Sally A. Stauffer.

Answer: Request No. 30 is admitted.

Request No. 31: At all times since its formation and during its existence plaintiff has controlled and dictated the policies and operations of said Stauffer System, Inc.

Answer: Request No. 31 is admitted.

Dated: October 12th, 1956.

/s/ BERNARD H. STAUFFER

Requests Dated: This 2nd day of Oct., 1956, at Los Angeles, California. Newlin, Taackabury & Johnston, Hudson B. Cox, Harris, Kiech, Foster & Harris, Ford Harris, Jr., Donald C. Russell, by Ford Harris, Jr., Attorneys for Defendant and Counterclaimant, Slenderella Systems of California, Inc.

Replies Duly Verified. [67]

Acknowledgment of Service attached. [68]

[Endorsed]: Request for Admissions Filed Oct. 3, 1956. Replies Filed Oct. 15, 1956.

[Title of District Court and Cause.]

DEFENDANT'S SECOND REQUEST  
FOR ADMISSIONS

Pursuant to Rule 36 of the Rules of Civil Procedure, the defendant in the above-entitled action hereby requests that plaintiff within ten (10) days after service hereof admit in writing the following matters:

1.

The document attached hereto as "Exhibit A" is in substance a copy of a document executed on September 25, 1953, by Bernard H. Stauffer and Stauffer System, Inc. named therein.

Dated: October 30, 1956.

HARRIS, KIECH, FOSTER &  
HARRIS and  
NEWLIN, TACKABURY &  
JOHNSTON,

/s/ By FORD HARRIS, JR.,  
Attorneys for Defendant and Counterclaimant,  
Slenderella Systems of California, Inc. [69]

[Note: Exhibit A is set out as Exhibit 15 in  
the Book of Exhibits.]

Acknowledgment of Service attached. [71]

[Endorsed]: Filed Nov. 2, 1956.



[Title of District Court and Cause.]

PLAINTIFF'S REPLY TO DEFENDANT'S  
SECOND REQUEST FOR ADMISSIONS

Comes now the plaintiff, Bernard H. Stauffer, and makes answer to the second request for admissions, dated October 30, 1956, as follows:

Request No. 1: The document attached hereto as "Exhibit A" is in substance a copy of a document executed on September 25, 1953, by Bernard H. Stauffer and Stauffer System, Inc. named therein.

Reply: Plaintiff admits the matter set forth in Request No. 1 quoted above.

/s/ BERNARD H. STAUFFER [73]

Duly Verified.

Acknowledgment of Receipt of Copy attached.

[Endorsed]: Filed Nov. 13, 1956.

---

[Title of District Court and Cause.]

MINUTES OF THE COURT

Date: Nov. 13, 1956, at Los Angeles, Calif.

Present: Hon Ernest A. Tolin, District Judge.

Deputy Clerk: Wm. A. White; Reporters alternating: Virginia Wright and A. H. Wahlberg.

Counsel for Plaintiff: Chas. G. Lyon.

Counsel for Defendant: Ford Harris, Jr., and Hudson B. Cox.

Proceedings: For trial. At 2:03 p.m. court convenes herein. All parties are present.

Attorney for plaintiff makes opening statement, and Attorney for defendant makes opening statement.

Plf's Ex. 1 is received in evidence, and Ex. 2 is marked for ident.

Jay Wiener is called, sworn, and testifies for plaintiff.

Plf's Ex. 3 is received in evidence, subject to motion to strike.

Bernard H. Stauffer, plaintiff, is called, sworn, and testifies in his own behalf.

Plf's Ex. 4 is received in evidence.

Plf's Ex. 5 and 6 are received in evidence.

It Is Ordered that further trial is continued to 1:45 p.m., Nov. 14, 1956.

JOHN A. CHILDRESS,

Clerk,

/s/ By WAYNE E. PAYNE,

Deputy Clerk [76]

---

[Title of District Court and Cause.]

### MINUTES OF THE COURT

Date: Nov. 14, 1956, at Los Angeles, Calif.

Present: Hon. Ernest A. Tolin, District Judge.

Deputy Clerks: W. E. Papyn, S. W. Stacey; Reporters alternating: Virginia Wright and A. H. Wahlberg.

Counsel for Plaintiff: Chas. G. Lyon.

Counsel for Defendant: Ford Harris, Jr., Hudson B. Cox.

Proceedings: For further Court trial. At 1:45 p.m. Court reconvenes herein. All parties are present and Court orders trial proceed.

Bernard H. Stauffer, plaintiff, resumes testifying in his own behalf.

Plf's Ex. 7 to 15 incl. are marked for ident., and Ex. 15 is received in evidence.

Defts' Ex. A-1, A-2, and A-3 are marked for ident.

Plf's Ex. 2 is received in evidence.

At 3 p.m. Court recesses. Court reconvenes after a short recess and all parties are present. Trial proceeds.

Douglas B. Nickerson is called, sworn, and testifies for plaintiff.

Plf's Ex. 16, 17, 18, and 19 are admitted in evidence.

It Is Ordered that cause is continued to 1:30 p.m., Nov. 15, 1956, for further trial.

JOHN A. CHILDRESS,  
Clerk [77]

---

[Title of District Court and Cause.]

### MINUTES OF THE COURT

Date: Nov. 15, 1956, at Los Angeles, Calif.

Present: Hon. Ernest A. Tolin, District Judge;

Deputy Clerk: W. E. Payne. Reporter: Virginia Wright.

Counsel for Plaintiff: Chas. G. Lyon.

Counsel for Defendants: Ford Harris, Jr., and Hudson B. Cox.

Proceedings: For further trial. At 1:35 P.M. court convenes herein. All counsel are present.

Plaintiff rests.

Defts'. Ex. B-1 is marked for ident., offered, and received into evidence. Defts'. Ex. B-2 and B-3 are marked for ident., offered, and objected to. Court Sustains objections and orders that said exhibits remain for identification.

Robert M. Knapp, witness for defendants, is called, sworn, and testifies.

Defts'. Ex. C is marked for ident.

At 2:45 P.M. court recesses.

At 3:07 P.M. court reconvenes herein, and all being present as before, trial proceeds.

Robert M. Knapp resumes testifying.

Defts' Ex. D, D-1, D-2, D-3 and E are marked for ident.

Defts' Ex. F is marked for ident.

Defts' Ex. E and F are received into evidence.

Defts' Ex. G to J are marked for ident. and received into evidence.

At 4:22 P.M. Court Orders cause continued to 1:30 P.M., Nov. 16, 1956, for further trial.

JOHN A. CHILDRESS,

Clerk,

By WAYNE E. PAYNE,

Deputy Clerk. [78]

[Title of District Court and Cause.]

MINUTES OF THE COURT

Date: Nov. 16, 1956. At: Los Angeles, Calif.

Present: Hon. Ernest A. Tolin, District Judge;

Deputy Clerk: W. E. Payne. Reporter: Virginia Wright.

Counsel for Plaintiff Charles G. Lyon;

Counsel for Defendants: Ford Harris, Jr., and Hudson B. Cox;

Proceedings: For further trial. Court convenes herein at 1:38 P.M. All parties are present. Court orders trial proceed.

Defts' Ex. C, D, D-1, D-2, and D-3 are received into evidence.

Robert M. Knapp resumes testifying.

Defts' Ex. K is marked, offered, and received into evidence.

At 2:50 P.M. court recesses. At 3:25 P.M. court reconvenes herein, and all being present as before, including counsel for both sides, trial proceeds.

Defts' Ex. L-1 to L-8 incl. are marked for ident. and received into evidence for a limited purpose until further decision by the Court.

Wm. I. Fishbein, witness for defendants, is called, sworn, and testifies.

Counsel for defendants moves to strike Plf's Ex. 3 and Court denies said motion.

Court states that mast-head and sound tract of film will not be considered as evidence.

At 4:12 P.M. It Is Ordered that cause is continued to Nov. 19, 1956, 10:30 A.M. for further trial.

JOHN A. CHILDRESS,  
Clerk,  
By WAYNE E. PAYNE,  
Deputy Clerk. [79]

---

[Title of District Court and Cause.]

### MINUTES OF THE COURT

Date: Nov. 19, 1956. At: Los Angeles, Calif.  
Present: Hon. Ernest A. Tolin, District Judge;  
Deputy Clerk: W. E. Payne. Reporter: Virginia Wright.

Counsel for Plaintiff: Charles G. Lyon.

Counsel for Defendants: Ford Harris, Jr., and Hudson B. Cox.

Proceedings: For further trial. At 11:03 A.M. court convenes herein. All parties are present. Court orders trial proceed.

Court Orders that deposition of plaintiff Bernard H. Stauffer and exhibits thereto filed. Attorney Cox reads portions of said deposition.

Attorney Cox offers Plf's Ex. 12 and 13 into evidence.

Attorney Lyon, for plaintiff, objects to said offer.

Court Orders Plf's Ex. 12 and 13 admitted into evidence.

Counsel for defendants defer evidence re attorneys' fees until Court decides the cause. Defendant rests.



Counsel for defendant withdraws second counter-claim.

On motion of counter-claiming defendant, Court Orders the second counter-claim dismissed.

Bernard H. Stauffer, plaintiff, resumes the stand and testifies in his own behalf in rebuttal.

At noon court recesses to 1:30 P.M. At 1:30 P.M. court reconvenes herein. All parties are present as before. Trial proceeds.

Plaintiff Stauffer resumes testifying.

Plf's Ex. 20 and 21, being the exhibits referred to in the deposition of Bernard H. Stauffer, plaintiff, are marked for identification, offered, stipulated to, and received into evidence.

Plaintiff rests and defendant rests.

Attorney Lyon makes closing argument on behalf of plaintiff.

Attorney Harris make closing argument on behalf of defendants.

Attorney Lyon makes final closing argument on behalf of plaintiff.

Court Finds that claim one is invalid for want of invention.

Counsel for defendants to prepare formal findings, conclusions, and judgment.

At 3:05 P.M. court adjourns.

JOHN A. CHILDRESS,  
Clerk,

By WAYNE E. PAYNE,  
Deputy Clerk. [80]

In The United States District Court, Southern  
District of California, Central Division

Civil Action No. 18,254-T

BERNARD H. STAUFFER, Plaintiff,

vs.

SLENDERELLA SYSTEMS OF CALIFORNIA,  
INC., Defendant and Counter-claimant,

STAUFFER SYSTEM, INC.,  
Counter-defendant.

FINDINGS OF FACT, CONCLUSIONS  
OF LAW AND JUDGMENT

Findings of Fact

1. The plaintiff, Bernard H. Stauffer, is a citizen of the United States and a resident of the City of Los Angeles, State of California.

2. The defendant, Slenderella Systems of California, Inc., is a California corporation having its principal place of business at Los Angeles, California. [81]

3. The Court has jurisdiction of this action under Sections 1338 and 2201 of Title 28, United States Code.

4. The plaintiff, Bernard H. Stauffer, is the owner of United States Letters Patent No. 2,240,679 in suit.

5. Only claim 1 of said Letters Patent No.

2,240,679 in suit is involved in this action, plaintiff at the trial having withdrawn his charge of infringement as to claim 2 of said Letters Patent.

6. Claim 1 of said Letters Patent No. 2,240,679 in suit relates to a muscle relaxing machine for use in treating a human body.

7. Claim 1 of said Letters Patent No. 2,240,679 in suit defines an assemblage of elements all of which were old in the prior art in which they operated in substantially the same way to produce substantially the same result, and such subject matter as a whole would have been obvious to and could have been produced by any person having ordinary skill in the art to which said subject matter pertains.

8. Claim 1 of said Letters Patent No. 2,240,679 is wanting in invention.

9. At the trial of this action the defendant's second counterclaim was withdrawn by stipulation of the parties.

#### Conclusions of Law

1. The Court has jurisdiction of the parties and over the subject matter set forth in the plaintiff's complaint, and the Court has jurisdiction of the parties and over the subject matter set forth in the defendant's first counterclaim. [82]

2. Claim 1 of said Letters Patent No. 2,240,679 in suit is invalid and void in law for lack of invention.

3. The defendant, Slenderella Systems of California, Inc., is entitled to judgment against the plaintiff, Bernard H. Stauffer, dismissing the complaint with prejudice.

4. The defendant, Slenderella Systems of California, Inc., is entitled to judgment on its first counterclaim herein for declaratory relief, adjudging claim 1 of said Letters Patent No. 2,240,679 in suit invalid and void.

### Judgment

In accordance with the foregoing Findings of Fact and Conclusions of Law, it is Ordered, Adjudged, and Decreed that:

1. Claim 1 of United States Letters Patent No. 2,240,679 is invalid and void in law.

2. The Complaint for Infringement of United States Letters Patent No. 2,240,679 is hereby dismissed with prejudice and plaintiff shall take nothing by his complaint herein.

3. The First Counterclaim for declaratory relief adjudging claim 1 of United States Letters Patent No. 2,240,679 invalid and void is hereby sustained.

4. The defendant, Slenderella Systems of California, Inc., shall have and recover from the plaintiff, Bernard H. Stauffer, [83] the taxable costs of the defendant in this Court in the sum of \$1,470.93—(Purs. Ord. Fld. 1/9/57).

Dated: This 27th day of November, 1956.

/s/ ERNEST A. TOLIN,

United States District Judge

Approved as to form:

LYON & LYON,

CHARLES G. LYON,

/s/ By CHARLES G. LYON,

Attorneys for Plaintiff. [84]

Acknowledgment of Receipt of Copy Attached. [85]

[Endorsed]: Lodged Nov. 21, 1956. Filed Nov. 27, 1956. Docketed and Entered Nov. 28, 1956.

---

[Title of District Court and Cause.]

NOTICE

To Bernard H. Stauffer, Lyon & Lyon and Charles G. Lyon, his attorneys:

You, and each of you, are hereby notified that defendant shall apply to the Clerk of the Court at the Post Office Building, Los Angeles, California, in his office, at 9:30 A.M., December 5, 1956, to tax the costs as set forth in the hereto annexed Bill of Costs, in accordance with the [86] provisions of the Federal Rules of Civil Procedure and of the local rules of the United States District Court for the Southern District of California, Central Division.

Dated: December 3, 1956.

HARRIS, KIECH, FOSTER &  
HARRIS,  
FORD HARRIS, JR.,  
DONALD C. RUSSELL,  
WALTON EUGENE TINSLEY,  
/s/ By WALTON EUGENE TINSLEY,  
Attorneys for Defendant and  
Counter-claimant. [87]

[Title of District Court and Cause.]

DEFENDANT'S BILL OF COSTS AND  
DISBURSEMENTS

1. Certified Copy of File Wrapper and Contents of Patent in suit No. 2,240,679 (Def. Ex. B-1)—\$37.00 (allowed).

2. Copies of three prior art patents (Def. Ex. D-1, 2, 3—75 cents (allowed).

3. Fees of reporter for original of deposition of Bernard H. Stauffer—\$104.48 (allowed) [88]

4. Dr. Fishbein—Witness fees, 5 days, \$20.00 (allowed); mileage, over 100 miles, \$7.00 (allowed); subsistence, 7 days, \$35.00 (allowed).

5. Robert T. Knapp—Witness fees, 4 days, \$16.00 (allowed); mileage, 96 miles, \$6.72 (allowed).

6. Preparation of blown-up charts of patent in suit and prior art patents with attached movable parts of transparent plastic illustrating operation (Def. Ex. E, F, G, H, I, J)—Photo enlargements \$76.44, material \$33.68, labor \$881.24 (disallowed on ground custom does not allow enlargements or models).

7. Preparation of drawing illustrating range of movement of defendant's machines (Def. Ex. C)—\$99.00 (allowed).

8. Preparation of chart with moving arm illustrating comparative movements of patented device and defendant's devices (Def. Ex. K) (disallowed as being a model).



9. Fees of reporter for one-half of cost of original transcript of proceedings at trial obtained for use of the Court, per stipulation of counsel—\$103.12 (allowed).

10. Attorneys' Docket Fee—\$20.00 (allowed).

Total—\$449.07.

The foregoing Bill of Costs and Disbursements taxed and allowed in the sum of \$449.07.

/s/ By JOHN A. CHILDRESS,

Clerk. [89]

Duly Verified. [90]

Acknowledgment of Receipt of Copy Attached.

[Endorsed]: Filed December 3, 1956. [91]



[Title of District Court and Cause.]

NOTICE OF AND MOTION TO RE-TAX  
COSTS UNDER RULE 54(d) F.R.C.P. AND  
LOCAL RULE 15(c)

To: Plaintiff Bernard H. Stauffer; Lyon & Lyon  
and Charles G. Lyon, his counsel.

Now comes the defendant Slenderella Systems of California, Inc., and gives notice that on Monday, January 7, 1957, at the hour of 10:00 o'clock a.m., or as soon thereafter as counsel can be heard, in the courtroom of this Court, in the United [92] States Post Office and Court House Building, Los Angeles, California, it will move this honorable

Court to re-tax the defendant's costs, items 6 and 8, disallowed by the Clerk, on December 5, 1956.

In support of this motion said defendant will rely upon the papers and pleadings on file herein and the annexed Memorandum of Points and Authorities.

Dated: At Los Angeles, California, this 10th day of December, 1956.

HARRIS, KIECH, FOSTER &  
HARRIS,  
FORD HARRIS, JR.,  
DONALD C. RUSSELL,  
WALTON EUGENE TINSLEY,  
NEWLIN, TACKABURY &  
JOHNSTON,  
HUDSON B. COX,

/s/ By WALTON EUGENE TINSLEY,  
Attorneys for Defendant and  
Counter-Claimant. [93]

Affidavit of Service by Mail Attached. [97]

[Endorsed]: Filed December 10, 1956.

---

[Title of District Court and Cause.]

#### NOTICE OF APPEAL

To: Slenderella Systems of California, Inc. and  
Harris, Kiech, Foster & Harris, its attorneys:

Notice is hereby given that Bernard H. Stauffer hereby appeals to the Court of Appeals for the Ninth Circuit from the judgment entered in this action on November 28, 1956.

Dated this 12th day of December, 1956.

LYON & LYON,

/s/ By CHARLES G. LYON,  
Attorneys for Plaintiff. [98]

Affidavit of Service by Mail Attached. [99]

[Endorsed]: Filed December 12, 1956.

---

[Title of District Court and Cause.]

SUPPLEMENTARY AFFIDAVIT RE DEFENDANT'S BILL OF COSTS AND DISBURSEMENTS

State of California

County of Los Angeles—ss.

Walton Eugene Tinsley, being first duly sworn, deposes and says: that he is one of the attorneys for the defendant in the above-entitled cause; that the costs and disbursements listed in [102] Defendant's Bill of Costs and Disbursements are correct and have been necessarily incurred in the defense of this cause; and that the services for which fees have been charged were actually and necessarily performed.

/s/ WALTON EUGENE TINSLEY

Subscribed and Sworn to before me this 14th day of December, 1956.

[Seal] /s/ BERNICE SHOEMAKER,  
Notary Public in and for said County and State.

Affidavit of Service by Mail Attached. [104]

[Endorsed]: Filed December 26, 1956.

[Title of District Court and Cause.]

ORDER GRANTING MOTION TO RE-TAX  
COSTS

This cause having come on for hearing on January 7, 1957, pursuant to defendant's Notice of and Motion to Re-Tax Costs filed December 10, 1956 and plaintiff's Memorandum in Opposition thereto filed on or about December 13, 1956; and oral argument having been heard on said day; and good cause appeared therefor; [105]

It Is Hereby Ordered, Adjudged and Decreed:

That the disallowance by the Clerk of Items 6 and 8 of the defendant's Bill of Costs and Disbursements are reversed.

That the Clerk is hereby directed to tax said Items 6 and 8 as costs in this matter and add costs in the amount of One Thousand Twenty-One and 86/100 Dollars (\$1,021.86) to the costs previously taxed making a total of One Thousand Four Hundred Seventy and 93/100 Dollars (\$1,470.93).

Dated: January 9, 1957.

/s/ ERNEST A. TOLIN,  
Judge

Approved as to form, this 9th day of January, 1957.

LYON & LYON,  
/s/ By CHARLES G. LYON,  
Attorneys for Plaintiff. [106]

[Endorsed]: Lodged and Filed January 9, 1957.

[Title of District Court and Cause.]

CERTIFICATE BY CLERK

I, John A. Childress, Clerk of the above-entitled Court, hereby certify that the items listed below constitute the transcript of record on appeal to the United States Court of Appeals for the Ninth Circuit, in the above-entitled cause:

A. The foregoing pages numbered 1 to 106, inclusive, containing the original

Complaint;

Answer and Counterclaims;

Order that Additional Party be Brought In;

Reply to Counterclaims;

Interrogatories propounded to Defendant;

Reply to Counterclaim;

Answers to Plaintiff's Interrogatories;

Defendant's First Request for Admissions;

Supplemental Answer to Plaintiff's Interrogatories;

Reply to Defendant's First Request for Admissions;

Defendant's Second Request for Admissions;

Plaintiff's Reply to Defendant's Second Request for Admissions;

Findings of Fact, Conclusions of Law, and Judgment;

Notice of Taxing Costs;

Defendant's Bill of Costs and Disbursements;

Notice of and Motion to Re-Tax Costs;

Notice of Appeal;

Designation of Record on Appeal;

Supplementary Affidavit re Defendant's Bill of Costs and Disbursements;

Order Granting Motion to Re-Tax Costs;

And a full, true and correct copy of the Minutes of the Court on October 3, 1955; November 13, 14, 15, 16, 19, 1956;

B. Three volumes of Reporter's Official Transcript of Proceedings had on November 19, 1956; November 13, 14, 1956; November 15, 16, 1956;

Plaintiff's exhibits 1-21, inclusive and Defendant's exhibits A-1—L-S, inclusive.

I further certify that my fee for preparing the foregoing record amounting to \$2.00, has been paid by appellant.

Witness my hand and the seal of said District Court, this 17th day of January, 1957.

[Seal] JOHN A. CHILDRESS,  
Clerk

/s/ By CHARLES E. JONES,  
Deputy



In the United States District Court Southern  
District of California, Central Division

No. 18,254-T

BERNARD H. STAUFFER, Plaintiff,

vs.

SLENDERELLA SYSTEMS OF CALIFORNIA,  
INC., Defendant.

REPORTER'S TRANSCRIPT OF  
PROCEEDINGS

Los Angeles, California  
Tuesday, November 13, 1956

Honorable Ernest A. Tolin, Judge Presiding.

Appearances: For the Plaintiff: Lyon & Lyon,  
811 West Seventh Street, Eighth Floor, Los An-  
geles, California, By: Charles G. Lyon. [1]\*

For the Defendant: Newlin, Holley, Tackabury &  
Johnston, 601 West Fifth Street, Suite 1020, Los  
Angeles, California, By: Hudson B. Cox. Harris,  
Kiech, Foster & Harris, 417 South Hill Street,  
Suite 321, Los Angeles, California, By Ford Harris,  
Jr. [2]

Tuesday, November 13, 1956; 2:04 P.M.

The Court: Are you ready to proceed?

---

\* Page numbers appearing at top of page of original Reporter's  
Transcript of Record.

Mr. Lyon: Plaintiff is ready.

Mr. Harris: The defendant is ready, your Honor.

The Court: All right.

Mr. Harris: First, the court please, we have stipulated certain documents and things asked of the plaintiff, to bring them in under subpoena duces tecum, and I might at this time inquire formally as to whether they are here or not.

Mr. Lyon: They will be. I understand our business manager has been delayed en route. He was to bring them.

The subpoena was served, one of them, Friday afternoon after I had left my office and gone to San Francisco, and the other one yesterday which, of course, was a holiday. I did not know anything about them until this morning and I immediately called Mr. Teasdale, our office manager, and asked him to assemble them, and he has been diligently working at them since then. They will be produced.

Mr. Harris: Thank you.

Mr. Lyon: The court please, this is a patent infringement suit brought by the plaintiff Bernard H. Stauffer, who is the inventor,—

The Court: I spent the last two hours reading the file, so I know what is in your trial memorandum and what is in the [3] pleadings. You can take it from there.

I am just saying that so that you will not be repeating material which has already been brought to the court's attention.

Mr. Lyon: Thank you. With that admonition, I will call to the witness stand Mr. Bernard Stauffer.

Mr. Harris: The court please, I would like to make a very brief opening statement before we take Mr. Stauffer's testimony.

The Court: All right.

Mr. Harris: If I may.

The Court: I didn't mean, Mr. Lyon, you can't make one but I am just suggesting that opening statements should expand upon, but should not repeat what has already been brought to my attention by the memorandum.

Mr. Lyon: I think we covered what I intended to say in our trial brief.

The Court: Your opponent apparently has something new.

Mr. Harris: Your Honor, I have some enlargements that I wish to refer to briefly in my statement. I don't know whether I can get the blackboard back there close to the lectern or not. Perhaps I can move it——

The Court: You can speak from where you are there,——

Mr. Harris: Yes.

The Court: ——just so you speak with enough force so [4] that the reporter hears you.

Mr. Harris: Yes, your Honor. I don't know whether your Honor can see that enlargement from there or not.

The Court: Well, I think I can. Some of the smaller portions I might have to come down for, but I will do that if necessary.

Mr. Harris: Yes. I shall merely hit the high

spots now, anyway. I wanted to show the court the patent in suit, the drawing of the patent in suit, and to speak just very briefly on the construction of the patent because I don't believe your Honor has seen the patent in suit.

The Court: Certainly. I have seen a soft copy of it, anyway.

Mr. Lyon: I put a copy on your desk, which is extra, and you can mark it up and tear it apart or do anything you want with it; it is yours.

Mr. Harris: Very well, your Honor. I am very glad of that, that your Honor has seen it.

The Court: I feel, not acquainted to the point that I can technically discuss it—I am not an engineer or draftsman—I do feel that I have a lay acquaintance with the patent in suit, in any event.

Mr. Harris: Yes, your Honor. Thank you. I will be very brief on this.

As your Honor knows, then, this patent relates to a [5] muscle relaxing machine, it is called. There may be some question in the evidence as to whether this machine actually does any muscle relaxing or not. But that will be a secondary point, if it is a point at all.

However, as your Honor undoubtedly is aware, this machine consists of a couch having a slot in the top of the couch, and it has an arm 20 which extends upwardly from a pivot point in its bottom (indicating).

On the top of the arm or support 20 is a flat rectangular applicator or seat 18 (indicating), which is stated in the patent in suit to move be-

tween the two positions shown in Figure 2 of the drawing, that is, the position shown in full lines to the position shown in dotted lines in Figure 2 of the drawing (indicating).

And as it is stated in the patent, that is the limit of motion of this applicator or seat, and the support for it is between the full and dotted line positions in this drawing (indicating). I emphasize that, if the court please, because there is going to be a serious issue in this case for your Honor to decide, as to whether the defendant's tables or machines operate in this same manner as shown in Figure 2 of the patent in suit and as described in the specification for the patent in suit.

We shall, of course, introduce into evidence the file wrapper history and contents of the Stauffer patent in suit. [6]

The Court: Which you say he abandoned—

Mr. Harris: I beg your pardon, your Honor?

The Court: Which you claim that the file wrapper will show that Stauffer in his application claimed what you are now using and then abandoned those claims?

Mr. Harris: Yes, exactly. I wish—

The Court: Yes, he is estopped, if that be true, to assert that they are included within the claims which have been allowed.

Mr. Harris: That is correct, your Honor, exactly right. I now hang on the blackboard, on the easel, an enlargement of the original drawing that was filed with the application for the Stauffer patent in suit. This is page 13 of the file wrapper,



which we shall introduce in evidence. This is merely an enlargement of page 13 of the file wrapper.

As your Honor will see in the original drawing submitted to the Patent Office, which was quite different from the drawing that is in the issued Stauffer patent.

In this drawing, the original drawing, the support Figure 20 and its applicator 18 move between dotted line positions, as shown in the Figure 2 of the drawing, from one side of the vertical to the other side of the vertical. And it is that arc of movement on both sides of the vertical that we are contending that the defendant uses in its machines.

It is that movement which the plaintiff, by canceling this drawing and substituting the drawing that shows in the patent as it issued, which constitutes the abandonment of this very form which is shown in the old original drawing, an abandonment of that form which is the form the defendant is using, so far as the motion of the applicator is concerned.

Now, there are many other differences between the mechanisms of either of these drawings, either the mechanism of the abandoned application drawing or the drawing of the patent in suit as it issued. There are many differences between those structures and the defendant's mechanism.

These differences I have just pointed out are the important ones, and may we say were abandoned by the plaintiff when he discarded this original drawing at page 13 of the file wrapper and substituted for it the drawing which appears in the patent in



suit, which shows an entirely different form of motion of the applicator and support.

I don't believe that the court has seen any of the file wrapper references that were considered by the Patent Office in connection with this patent in suit, nor do I believe that the court has seen any of the three prior art patents upon which the defendant relies.

The Court: That is correct. Those were not included in the memoranda.

Mr. Harris: No. [8]

The Court: They are referred to, but not included.

Mr. Harris: I am sorry, your Honor. I should have included them. At any rate, I will very briefly point out to the court what these three prior art patents disclose so that your Honor may have that in mind during the trial of the case.

First of all, the defendant will rely upon a patent issued to T. M. Parker, No. 1,978,223 on October 23, 1934, sometime prior to the issuance or even the application for the Stauffer patent in suit.

This Parker patent was considered by the Patent Office. It shows a couch which is shown here in Figure 2 in side view in section (indicating). Figure 1 shows a top view of the couch (indicating).

The couch has a slot in its top surface up through which extends a series of six applications (indicating).

Each of these applicators is pivoted at a pivot point 36 and is connected to an arm or bar 23 shown in the Parker patent which, in turn, is con-

nected through a connecting rod and an eccentric driven by a pulley to an electric motor (indicating).

Upon operation of this mechanism the motor drives the pulley, the pulley reciprocates this connecting rod 27 back and forth, to make these applicators pivot about there at pivot points 36 (indicating). They pivot in that manner about those pivot points 36 to give substantially the same [9] motion to the applicators as was true of the applicator shown in the drawing of the original Stauffer patent drawing.

It is a motion on both sides of the vertical here (indicating), exactly as it was in the original patent drawing of Stauffer. That we shall say, of course, is a complete anticipation of the claims in suit. Also, we shall say that there was no invention in the claims in suit, in view of that Parker patent.

But I think that that suffices for the present, to indicate to the court the general construction of the Parker patent, and the fact that these applicators move in the Parker patent in substantially the same way that the applicators move in the defendant's device.

The Court: Well, if that be so, it would have been much safer for this defendant to have simply built his structure on the Parker specification, because that patent has expired.

Mr. Harris: We think we did. We think the defendant did do that exactly. That is our contention, if the court please.

The Court: I don't get that from the drawings you have. Of course, those are Stauffer drawings.

Mr. Harris: Yes, these are the Stauffer drawings we have illustrated here, the drawings in the patent and in the application for the patent.

The Court: Are you contending then your [10] client is vending the Parker device, rather than the Stauffer?

Mr. Harris: Well, if we are vending either one of them, we are vending the Parker device, because our applicators move in the same way.

The Court: Vending or using. I take it even possessing one would be an infringement, wouldn't it?

Mr. Harris: No,—

The Court: If this is an infringing patent.

Mr. Harris: I think it would have to be used. Infringement can only arise through manufacture, use or sale. Unless it is used there would be no infringement.

Mere possession is not sufficient, but we are not concerned with that in the case, anyway, because we admit use of whatever we are making, and use it.

I wanted to point out to the court that that is the type of movement, the same type of movement of the applicators that the defendant has in its tables or machines that are here charged with infringement.

Next, if the court please, we are relying upon another early patent, a patent to Miller, No. 1,953,-424, which issued on April 3, 1934. Again, several years before the application was filed for the Stauffer patent in suit.

The Miller patent, as in Parker, shows a couch or a table which is No. 20 in the drawings of the Miller Patent, and upon which a patient or a user is supposed to lie for [11] these treatments.

It has a pad extending up through a slot in the top surface of the table or couch, which moves to give the desired treatment to the patient or user.

As shown in Figure 4 of the Miller patent, or, I should say Figure 4 of the Miller patent shows more clearly the mechanical construction of the mechanism, including the pad and its mounting and the drive mechanism for operating it.

The evidence will show that this pad can be adjusted in various positions by this linkage mechanism, and when driven the connecting rod 71 is reciprocated back and forth to operate this mechanism, which supports the pad 27, to move the pad forwardly and backwardly, upwardly and downwardly in the same general sort of motion, we suggest, as is shown in drawings of the Stauffer patent in suit and as is described in the specifications for the Stauffer patent in suit. We suggest that this is another prior art patent which shows the same general type of movement as that in the plaintiff's patent in suit.

I might say, if the court please, that this Miller patent was not before the Patent Office when they considered the Stauffer application for his patent. This was a patent that we found in a remote place in the Patent Office, which had not been considered by the Patent Office in its allowance of the Stauffer patent. [12]

Under the well-known rule of law that destroys any presumption of validity attaching to the Stauffer patent by reason of the issuance——

The Court: Well, it does if this is actually an equivalent structure, doesn't it? It doesn't destroy the presumption of validity because there is something else in the art.

Mr. Harris: Oh, certainly not, your Honor. The destruction of the presumption of validity comes through the fact that here was a patent which is possibly even more pertinent to the Stauffer construction than were the patents which were considered by the Patent Office when they considered the Stauffer application.

The Court: And which they overlooked.

Mr. Harris: This one they overlooked, that is correct. Then lastly, we rely upon a patent to Gunderman, No. 1,825,588. This patent is a patent on a portable vibrating machine, as it is called.

It has a motor No. 10 mounted on a base No. 11, upon which is pivotally mounted, at a pivot point 40, and an upstanding arm or support 31 on which is fixed a curved plate 26 on the top (indicating).

The upstanding arm or support 31 is connected to the motor, the drive shaft of the motor, through a connecting rod 50, which is connected to an eccentric or cam which is rotated by the drive shaft of the motor to reciprocate the [13] connecting rod.

That action oscillates this upstanding arm or support 31, on both sides of the vertical, to provide mechanical massage for a patient exactly the same way that the Stauffer patent in suit does, in so far



as the Stauffer patent applies to an oscillation of a plate to provide a mechanical massage.

Of course, this is very much like, if not identical, with the defendant's structure in which it moves on both sides of the vertical by the same general sort of drive (indicating).

It is our contention, of course, that if anyone wants to put a couch around this mechanism of the Gunderman patent, so that you can lie on this plate and thereby massage your back instead of your feet or some other part you can rest on the plate, there is no infringement involved in the thing. As a matter of fact, in the file wrapper of the Stauffer patent in suit Mr. Stauffer's attorney admitted to the Patent Office that couches of this general type here were old in the art (indicating); a matter of public property.

There is nothing new in the couch idea. So we suggest there be no invention in putting a couch around the oscillating plate 26 of the Gunderman patent. Other details of this patent will appear from the evidence.

There are two of these plates sides by side, exactly as in the defendant's mechanism (indicating). They are curved. [14]

Whereas, in Stauffer's the plates are flat. And I ask the court to mark than and mark it well because Claim 1 of the patent in suit says a flat applicator. The defendants use a curved applicator, as used in Gunderman.

We suggest, the court please, that the defendant in its machine follows the construction of these



prior art patents, and does not follow the construction of the Stauffer patent, and the rest of our contentions as to the lack of infringement are set forth in our memorandum.

The Court: Was Gunderman cited in the Patent Office?

Mr. Harris: Again Gunderman was another patent which was not cited in the Patent Office. The Patent Office did not consider Gunderman, did not find it. It is not cited.

The Court: It doesn't appear you reclined to use Gunderman.

Mr. Harris: The patent says you can put your feet on this plate 26 or you may sit on it (indicating). It says also that you may use it to manipulate other parts of the body.

You obviously couldn't lie on this thing, unless you put some kind of supporting structure around it.

But it is a massaging mechanism, as set forth in the Gunderman patent.

The Court: They are all massaging mechanisms of one kind or another, aren't they? [15]

Mr. Harris: Yes.

Mr. Lyon: I think I should point out this is not a massaging mechanism. In all the massaging mechanisms you will find a gear reduction system, so that you don't have what is, in effect, a vibrator; this is a vibrator (indicating).

The Court: Do you contend that Stauffer is not a vibrator?

Mr. Lyon: Stauffer is a manipulator. Of course,

there will be some testimony as to what is the difference between vibration and manipulation. It has to do with the question of rate of speed.

Mr. Harris: But I think, if the court please, with these prior art patents before you at the outset of the case your Honor can better judge the merits of the plaintiff's case here.

Also, at this time, if the court please, I would like to find out from the plaintiff whether the plaintiff is relying upon both Claims 1 and 2 of the Stauffer patent in suit, as being infringed by the defendant, or whether the plaintiff shall only rely upon one of those two claims, and if so, which one.

The Court: He pleads both, doesn't he?

Mr. Lyon: If your Honor please, I had an engineer take the drawings that were submitted to me by the defendant, as [16] showing the two different types of tables they make.

I had him lay them out on these bread boards, which I have here before me (indicating). Unfortunately, when he put them together he took the crank arm that runs to the reciprocated shaft (indicating), which carries the pad in the defendant's device, and substituted it with the crank arm which operates the whole table (indicating), which changed the motion enough so that in the model, as he had it last Friday before we corrected the error, the motion was entirely to one side of vertical. Since we have corrected the model, it presently operates as in accordance with the drawing.

Mr. Harris: Excuse me, Mr. Lyon.

Mr. Lyon: The motion is equally distant on both

sides of the table. And assuming the drawing is correct, I will withdraw the charge of infringement of Claim 2, and we will proceed entirely on Claim 1.

Mr. Harris: Thank you.

Mr. Lyon: Does that conclude your presentation, Mr. Harris?

Mr. Harris: Yes.

Mr. Lyon: I notice I have in the courtroom a gentleman whom I didn't expect to be here. Though it is perhaps a bit out of order I will, with the court's permission, interrupt the usual presentation of the case so that we may present a movie and then the photographer can go on his way. [17]

First, I would like to offer in evidence as Plaintiff's Exhibit 1 a flat copy of the Stauffer Patent No. 2,240,679.

The Court: Received.

(The document referred to was received in evidence and marked Plaintiff's Exhibit No. 1)

[See Book of Exhibits]

Mr. Lyon: Next I offer in evidence as Plaintiff's Exhibit 2 a unit known as the Stauffer Home Unit, lying here on the floor (indicating), as the Stauffer home unit is used in the movie which we will see.

Mr. Harris: If the court please, I shall have an objection to this unit because it will be our contention that that is not built in accordance with the patent in suit. It is therefore irrelevant and immaterial. I will make the same objection to the movie.

The Court: Well, there is no foundation for this physical structure which you are offering. But there is a foundation by stipulation or, at least, common

consent in your opening statement to the first exhibit which we received.

So you will have to have some foundation for this physical structure and also some foundation for your cinema.

Mr. Lyon: For my what?

The Court: For your movie. I call it a cinema.

Mr. Lyon: Will you take the stand, please?

The Court: We are supposed to use the more [18] elaborate words if we can.

#### JAY WEINER

called as a witness by and on behalf of the plaintiff, having been first duly sworn, was examined and testified as follows:

The Clerk: Will you please be seated.

Your name, sir.

The Witness: Jay Weiner.

#### Direct Examination

Q. (By Mr. Lyon): What is your occupation, Mr. Weiner?

A. I am the medical director for a division of a Stauffer System called the metabolade.

Q. As medical director of the Stauffer System, have you caused to be photographed in motion picture and in X-ray a person being treated in accordance with the Stauffer System, as you understand it?

A. I have, yes.

Q. Do you have that motion picture with you?

A. I have.

(Testimony of Jay Weiner.)

Q. Are you prepared to show the picture to the court? A. I am.

Q. And does that picture, in accordance with your own knowledge, show the manipulation of the body which is attendant the taking of a Stauffer treatment? A. It does. [19]

Mr. Lyon: With the court's permission, I will now ask the witness to show the court the movie.

The Court: Of course, you are not getting the movie into the record by this method. You get the movie into the record by having the actual film received and then having us see a projection of it.

Q. (By Mr. Lyon): Do you have the film with you, sir? A. Yes.

Mr. Lyon: I offer the film produced by the witness as——

I think we shall mark the home unit, at least, for identification as Exhibit 2 and the movie will be Plaintiff's Exhibit 3.

(The objects referred to were marked Plaintiff's Exhibits Nos. 2 and 3 respectively for identification.)

Mr. Harris: The court please, I should have an objection to the movie. We haven't seen the movie and I think that, in fairness to us as counsel, we should be entitled to see the movie, to permit us to state an objection to it if we think it is objectionable, before it is offered.

The Court: You haven't heard the witness, either?

Mr. Harris: We haven't heard the witnesses, either.



(Testimony of Jay Weiner.)

The Court: It isn't a prerequisite to evidence that it be something, or, the reception of evidence, that offered evidence be something which has been exposed to your view before. We just want to know whether this is a picture of what it [20] purports to be.

You may voir dire the witness on that, if you wish.

Mr. Harris: Yes, I would like to voir dire the witness.

The Court: All right.

Mr. Harris: What type of unit was this motion picture made with, Mr. Weiner?

The Witness: The particular unit that is demonstrated in front of you (indicating).

Q. (By Mr. Lyon): You are pointing to Plaintiff's Exhibit 2 for identification?

A. That is correct?

Mr. Harris: Are you an engineer?

The Witness: No, sir, I am not.

Mr. Harris: Are you a doctor of medicine?

The Witness: No, sir, I am not.

Mr. Harris: Are you familiar with mechanics and mechanical movements?

The Witness: Let's say in common lay language and terminology, yes.

Mr. Harris: You are simply a layman?

The Witness: That is correct.

Mr. Harris: Are you familiar with the detailed mechanism of of this table, Plaintiff's Exhibit 2 for identification?



(Testimony of Jay Weiner.)

The Witness: Familiar for identification? Yes.

Mr. Harris: No. Are you familiar with the [21] mechanism of that table?

The Witness: Yes, sir.

Mr. Harris: To what extent?

The Witness: The means and method by which it moves, the means and methods by which it is constructed for its use and application.

Mr. Harris: Are you familiar with its mechanical movements?

The Witness: Yes, sir.

Mr. Harris: I think, if the court please, we should have this table demonstrated at this time to see how it does move.

The Court: He purports to do that by showing a picture of it.

Isn't that what you want to do through this offered Exhibit 3?

Mr. Lyon: I will accept the challenge of the defendant, or the defendant's counsel and turn on Plaintiff's Exhibit 2.

The Court: Can you move it out a little so I can see it from here? Just move it back toward the podium a little way.

(Mr. Lyon complies.)

The Court: Thank you.

Mr. Harris: Mr. Weiner, can you see the operation of this mechanism, Exhibit 2 for identification?

The Witness: The operation of it? [22]

(Testimony of Jay Weiner.)

Mr. Harris: Can you see the operation from where you sit there?

The Witness: Yes, sir.

Mr. Harris: You notice, do you not, that the—what do you call this thing I am pointing to here (indicating)?

The Witness: I refer to it as a transducer.

Mr. Harris: Is that a pad (indicating)?

The Witness: That would be a very loose term for it, would be a pad or paddle.

Mr. Harris: It is a pad or paddle which is adapted to engage a user, is it not?

The Court: By “user” you mean the person who is—

Mr. Harris: The person who is reclining on the structure.

The Court: Do you understand the question?

The Witness: Yes, but I am not sure I can say it is designed to—how did you make your statement?

The Court: He said to engage.

Mr. Harris: I asked, is it designed to engage—

The Witness: I am not sure I can say it is designed to engage the user.

Mr. Harris: When a user lies on this table, Exhibit 2 for identification, this pad or paddle we are referring to—(indicating)—

The Witness: That contacts. [23]

Mr. Harris:—it contacts the user, does it not?

The Witness: But I am not certain under your definition it necessarily engages the user.

(Testimony of Jay Weiner.)

Mr. Harris: I wouldn't quibble with the witness on terms.

What is the extent of movement of this pad or paddle which I am pointing to in Exhibit 2?

The Witness: Three-quarters of an inch.

Mr. Harris: On both sides of the vertical?

The Witness: No, sir, that is total.

Mr. Harris: The total movement?

The Witness: Total movement, to the best of my knowledge.

Mr. Harris: It moves from half that distance on one side of the vertical to half that distance on the other side of the vertical, does it not?

The Witness: Yes, to the best of my knowledge, it is a three-quarter inch movement.

Mr. Harris: Have you ever seen the internal mechanism of a device like Exhibit 2, the operating mechanism?

The Witness: I have seen the internal devices of these particular machines, but I haven't seen like in any other equipment.

Mr. Harris: Have you ever seen the internal mechanism of this particular machine (indicating)?

The Witness: Yes, sir.

Mr. Harris: Would you describe that mechanism, please?

The Witness: This will be a little difficult but I can. It operates off a small motor. I believe it is a 12-horsepower motor. It operates in a cam, so that the arm on here (indicating) works off center on the cam to increase—so that the major

(Testimony of Jay Weiner.)

part of the stroke on the arm is above the surface of the table.

Mr. Harris: If the court please, based upon this voir dire examination we object to any showing of any motion picture of this table on the ground that this table obviously does not come within Claim 1 of the Stauffer patent in suit, because here we have a motion on both sides of the vertical and the patent in suit—not once but three times in different terms—points out that the motion is all on one side of the vertical.

Mr. Lyon: Where does it say any such thing in Claim 1?

The Court: Do you want to say something, Mr. Lyon?

Mr. Lyon: I just asked counsel where any such limitation appears in Claim 1.

Claim 1 doesn't have any limitation as to the movement, except that it will be tiltingly oscillated. Claim 2 is limited to a certain part.

It is elementary patent law, where you have one claim that has one meaning and another claim that has a different [25] meaning, you will not read the second one as meaning the same thing as the first.

Mr. Harris: We have the further objection, the court please, that is, there has been no foundation laid to show any motion picture of this machine, because there is no evidence in this case this particular table, Exhibit 2 for identification, is built in accordance with or under the patent in suit. It is

(Testimony of Jay Weiner.)

simply something that plaintiff's counsel says it is, but that is not evidence.

Mr. Lyon: I was admitting, Mr. Harris, I was proceeding somewhat out of order and I probably should first put Mr. Stauffer on and have him testify this table was made in accordance with his understanding of his patent. He will so testify. But I wanted to get rid of the motion picture.

The Court: In the interest of expedition we allow a variation in the order of proof, so we will admit Exhibit 3 subject to a motion to strike if it is not connected up. We will hear the evidence and see the picture.

(The object previously marked Plaintiff's Exhibit No. 3 for identification was received in evidence.)

Mr. Harris: We shall rely upon your Honor's judgment to separate the wheat from the chaff in the case. We will make such a motion later.

Mr. Lyon: I offer Plaintiff's Exhibit 3 subject to the motion to strike. [26]

The Court: It is received subject to the motion.

Q. (By Mr. Lyon): Will you now show the movie, please, Mr. Weiner? A. Yes, sir.

Mr. Lyon: It will take maybe five minutes to set up. Do you want to take a recess at this time, sir?

The Court: It will take five minutes to set it up?

Q. (By Mr. Lyon): Will it?

A. I imagine so, three to five minutes.

The Court: Let's stay in session but don't feel



(Testimony of Jay Weiner.)

that you are rushed. Whenever I take a recess some lawyer comes in and the recess gets extended.

Mr. Lyon: I think if you set up your screen here and project from—the projector can go on the clerk's bench if you like.

I might add, your Honor, I am informed this motion picture you will see, a portion of it is in X-ray, and is the third motion picture in history made in X-ray.

Mr. Harris: I wonder, if the court please, if I might ask one more question of the witness while he is wandering around, and that is, did he make this motion picture himself personally?

Mr. Lyon: No, he did not.

The Witness: You are asking——

Mr. Lyon: It was made under his supervision.

Mr. Harris: Pardon me. Would you answer the question?

The Witness: No, I didn't make it. It was made under my supervision by two—they will be identified on the screen.

The Court: Is it true, Mr. Lyon, the life of a patent is 17 years?

Mr. Lyon: Generally speaking that is quite true. It is possible to get a patent extended either by Act of Congress or if the patentee can show that due to World War II or the Korean war he was prevented from commercializing the same, and that he himself was in the service of his country during that time, the Commissioner has authority to extend the life of the patent, I believe, by twice the number



(Testimony of Jay Weiner.)

of days he was in the service. I tried one patent which was so extended here in this court.

The Court: Unless this patent has been so extended it has less than two years to live.

Mr. Lyon: Correct. It has not been extended. Design patent is a somewhat different situation. Design patents are issued for 3½, 7 and 14 years, depending on how much of a fee the patentee wants to pay.

The Court: This one has only 18 months of life, if the date on your soft copy here is correct.

Mr. Lyon: This patent will expire May 6, 1958.

The Witness: Now can I have the lights out, please? [28]

I am having trouble with the sound pickup on this. Have you pulled that over for any reason over there, the sound?

Wait until the sound comes in. Is it coming in now?

Mr. Lyon: It is making a noise.

Mr. Harris: The sound is hearsay, if the court please. I want the sound turned off.

The Court: What makes it hearsay? It is part of the physical exhibit.

Mr. Harris: Very well, your Honor.

The Court: The sound will be treated as argument, not as evidence. The picture is evidence of what it shows.

The Witness: If I might have a light here, your Honor. I don't know what is wrong here with the sound pickup. We ran this at one of the hospitals

(Testimony of Jay Weiner.)

this morning and it was all right. If you will bear with me a minute.

The Court: Yes.

Mr. Harris: Pardon me, if the court please.

Who made the sound track?

The Witness: The men that are on the film.

Mr. Harris: The men's names on the film?

The Witness: That is correct.

Mr. Harris: Are they going to be produced here for cross examination?

Mr. Lyon: They can be, if necessary.

Mr. Harris: It is all hearsay. [29]

The Court: I take it they are merely giving a commentary in order to explain the physical objects depicted in the picture.

Mr. Harris: I don't doubt that, your Honor, but it is hearsay.

The Court: So is the argument of counsel. We will treat this the same way.

Mr. Lyon: Demonstrations in court always go haywire.

The Witness: It never fails, does it?

Mr. Lyon: There is the sound.

The Witness: Yes, but it isn't coming off my film. The film is over the sound pickup here. I have another tube here.

Mr. Lyon: It only takes 12 minutes after we get it going.

It is stipulated by and by and between the parties that the court reporter shall provide the original transcript for the judge's use, the cost of the same

(Testimony of Jay Weiner.)

to be taxed against the losing party. So stipulated?

Mr. Harris: I am afraid that won't be satisfactory with the reporter. I think we ought to stipulate that each party pay half the cost and then the winning party's cost shall be taxed as costs in the case.

The Court: I understand that is what Mr. Lyon had in mind. [30]

Mr. Lyon: Let's get the lights out. All we are going to be able to show is the movie part——

(Thereupon, Exhibit No. 3 was run through a movie projector with the sound track working through only a portion of the Exhibit 3 in words as follows:)

A Voice: “\* \* \* the flexion of the cervical vertebrae, arching of one vertebra upon another.

“The movements of the arrow coincide with the action of the transducer. The transducer beneath the shoulders also tilts the upper thorax, extends the diameter of the rib cage superally, and induces elevation of the clavicle.

“In addition, a lateral movement of the shoulder produces a rhythmic stretching of the pectoral muscles.

“Movement of the clavicle upon the sternum can be seen and the rotation of the upper rib cage observed. In the lower portion of the rib cage a certain amount of rotation is also observed.

“There movements of the rib cage are detected by the sternum mastoid, the intercostals and the scapular muscles, producing elevation and lateral

(Testimony of Jay Weiner.)

rotation of the thoracic cage. The momentum induced within the body also assists in these motions.

“The lower ribs are marked to show the motions of the thorax in relation to the rest of the ilium, which has also been marked.

“The movements of the abdominal wall are seen. The abdominal contents ultimately move against the diaphragm, exerting a pumping action within the thorax. A superimposed rhythmic motion is thus transmitted to the heart and its associated structures.

“And even greater movement of the abdomen is observed when the transducer is placed beneath the hips. A rotatory movement of the pelvis through an arc tends to stretch the longitudinal vertebral ligaments. A weight placed across the hips produces permanent fixation of the thorax against the transducer and results in a more pronounced lifting effect. A greater excursion of the abdominal musculature and a greater attraction upon the pelvic ligaments and gluteal musculature occurs.

“In this animation, with the transducer placed beneath the shoulders as before, the changes in diameter of the chest produced by rotation of the costal vertebral articulation are demonstrated.

“The movement of the barium filled esophagus also follows the rhythmic motion of the transducer.

“When the subject sets directly upon the transducer a considerably greater body motion is induced. This position produces an alternating flex-

(Testimony of Jay Weiner.)

ion and extension of the muscle sacral angles and the lateral body wall.

“Posteriorly the markings over the spinous processes of the vertebrae and ilia crest indicates the wide degree of motion occurring in this position. This motion tends to stretch the anterior and posterior longitudinal ligaments and the sacro-iliae and sacro-lumbar ligaments as well.

“The plus marker has been placed over the lumbo-sacral articulation. The wide range of motion in this position between the lumbar vertebrae can be readily seen. The erector spinalis supra muscles are brought forcefully into play in this position. A metal marker is used as a reference point to determine excursions of the lumbar spine.

“The widening and narrowing of the spaces between the vertebrae in this X-ray motion picture demonstrates the repeated mild traction and release which is being produced.

“In this final position the transducer is placed longitudinally beneath the back. This imparts a vigorous motion to the abdomen. In addition, [33] this lateral motion produces a rhythmic stretch of the lateral trunk and thigh ligaments and muscles.

“The rhythmic motions induced have been demonstrated to exert an exercise effect, together with regular measured gentle traction, alternated with periods of relaxation.”

The Witness: Thank you for your patience, your Honor. I can wind this back while they are talking.



(Testimony of Jay Weiner.)

Do you want this as a part of your evidence?

The Court: Yes.

Q. (By Mr. Lyon): I think, Mr. Weiner, if you will resume the stand we can rewind that and put it back in its case during the afternoon recess.

A. All right.

Q. Will you explain in general what your duties are with the Stauffer System?

A. Yes, sir. A while back, approximately a year and a half ago, Mr. Stauffer had decided to present his equipment for use in the medical profession.

Since I had had some experience in marketing and research and so on in the past, I was given the position of doing the research work and development with doctors, with hospitals, with clinics, setting up research background material in the use of this equipment therapeutically. [34]

Q. When you say "this equipment" what are you referring to?

A. I am referring to the equipment illustrated in the film and the mechanical device here on the floor (indicating).

Q. Plaintiff's Exhibit 2 for identification?

A. That is correct.

Q. This Stauffer Home Unit (indicating)?

A. Yes.

Q. Just what have you been able to establish in the way of medical use for experimentation with the Stauffer table?

Mr. Harris: If the court please, that is objected



(Testimony of Jay Weiner.)

to on the ground no foundation has been laid for this witness, a lay witness, to testify to such matters.

Mr. Lyon: He testified that is what his business is.

The Court: It is not evidence of the therapeutic benefits, is it?

Mr. Harris: I am afraid that is what he is going to say. That is why I objected to the question.

The Court: The court would rather like to hear it as general orientation matter. But if it comes down to getting just how much a muscle is stretched, we will have to have expert testimony. He may answer.

The Witness: Will you restate the question again, Mr. [35] Lyon?

Q. (By Mr. Lyon): The question was, just what has been undertaken in connection with the use or experimentation with a Stauffer table by the medical profession?

A. Well, I first tried to establish that the operation of this particular device of the Stauffers, this mechanical process, did produce exercise in the human body.

I solicited the help of a Dr. Lawrence Morehouse, a P.H.D. in physiology and instructor in physical education and rehabilitation at UCLA.

He with four other men—two other physiologists, registered physical therapist and a master in physiology—did the work to determine whether this actually had the equivalent of physical exercise in

(Testimony of Jay Weiner.)

its value. His report, I believe, you have available.

The Court: He can't tell what is in the report.

The Witness: No, I am not trying to make any diagnosis. Secondly, I presented the equipment to Dr. John Aldes at Cedars of Lebanon Hospital in physical rehabilitation.

Dr. Aldes has been using the equipment for seven months there, working on osteo-arthritis cases and low back cases and cervical problems and Berger's disease. He is about due to publish his report. He tells me it is quite a favorable report at present.

Mr. Harris: The court please, this is all hearsay. It [36] isn't what he knows about these facts. He is just repeating hearsay.

Mr. Lyon: The last part of the answer may be stricken?

The Court: What the results of the doctor's work has been, if it is important, we will have to hear from the doctor himself.

I think very little of this, Mr. Lyon,—

Mr. Lyon: This shouldn't take very long, your Honor, and I will be finished with this witness. He has two or three more projects, I believe, to testify about.

The Court: I think he may testify about them, just as long as he doesn't invade the expert field or relate hearsay. We are receiving it as general orientation matter.

Mr. Lyon: Yes.

The Witness: The balance of the projects that I am supervising, your Honor, or trying to place,

(Testimony of Jay Weiner.)

one of them is at White Memorial Hospital in the study of the use of this type of motion on the reducing of blood sugars in diabetic subjects. That work is being done by Dr. Pote.

I have another project at the present time at Bellevue Hospital in New York. Dr. Albert Haas is doing work on the study of the influence of this type of motion, this particular motion, on emphysema.

I have another project being done at the Sister Kenney Foundation on the use of this type of motion—Dr. Lingren, [37] and again Dr. Raymond—on the influence of this type of motion on rehabilitation in post-polio cases.

I might add there is one other project at Cedars of Lebanon Hospital. They are working on multiple sclerosis and have been for several months.

To the best of my knowledge—oh, I have one other project just starting now. Joslyn Clinic in Boston have agreed to do additional research work on the use of this particular motion on reducing of blood sugars in diabetics.

Q. (By Mr. Lyon): You several times in your conversation stated that these various investigations are concerning the use of “this motion.” By “this motion” I take it you mean the motion of Plaintiff’s Exhibit 2 and the motion that is shown in the film, Plaintiff’s Exhibit 3.

A. That is correct.

Mr. Lyon: You may cross examine.

(Testimony of Jay Weiner.)

Mr. Harris: No cross examination, the court please.

(Witness excused.)

Mr. Harris: The court please, the last witness has asked me if he may take his projector. I am afraid if he rewinds the thing here now it would bother our hearing the witness testify. Whatever your Honor cares to do, though.

The Court: Can't he take it out into one of our anterooms?

Mr. Weiner: Yes, I can, I certainly can. [38]

The Court: Go through that door and through the next one (indicating) and my secretary will show you where you can work.

Mr. Weiner: Thank you.

The Court: The bailiff will help you carry it out.

### BERNARD H. STAUFFER

called as a witness in his own behalf, having been first duly sworn, was examined and testified as follows:

The Clerk: Please be seated.

Please state your name.

The Witness: Bernard H. Stauffer.

### Direct Examination

Q. (By Mr. Lyon): Mr. Stauffer, you are the Bernard H. Stauffer who is patentee of Letters Patent No. 2,240,679, the patent in suit here, are you?

A. Yes, sir, I am.

Q. You are the plaintiff in this case?

A. Yes, sir.

(Testimony of Bernard H. Stauffer.)

Q. I have laid before you a flat copy of the patent in suit. I will ask you to explain to the court—not going completely through the specification—just briefly and making a record for the Court of Appeals, as to what is shown in this patent, in the specification thereof.

A. It is a motor with a reduction gear—— [39]

Q. The motor is No. 50 in the patent?

A. Motor No. 50, with a reduction gear in a belt combination extending into a large pulley, which has an eccentric.

Q. The pulley is No. 48, is it not? I wish you would give the numbers as you go along.

The Court: I understand he is using Figure 6?

The Witness: Figure 2, your Honor.

The Court: Figure 2. I was trying to follow you on Figure 6. Perhaps that is where I was getting into difficulty.

The Witness: I will use Figure 6. I think it might be easier to follow.

The Court: All right. And refer to each number where you are telling us about some member.

The Witness: Yes, sir. The gear reduction is affected by the motor pulley with the belt 52 onto the large pulley, of which there is a shaft running through the center which is No. 42.

On shaft 42 is an eccentric, eccentric 38.

Q. (By Mr. Lyon): Eccentric what?

A. 38. That is coupled with the pinion 30, which drives a rod 28, which is attached to the perpendicular membrane 20.



(Testimony of Bernard H. Stauffer.)

20 is anchored at the base of 21, which is a bearing [40] permitting the upright unit 20 to go back and forth through an arc.

At the top of 20 is a paddle or a platform 18, which carries that portion of the body that is being activated while the patient is on the unit or the table.

Q. What is the device that supports the major portion of the body of the patient?

A. The device that supports the major portion of the body is the couch. And as this applicator extends up through the slot in the couch a part of the weight of the body is supported on the movable platform 18.

Q. With the portion of the body supported on the couch, and a portion of the body, shall we say, the buttocks, being supported on the pad 18, when you reciprocate that arm 20, carrying the pad through the arc indicated in your patent, what happens.

Mr. Harris: The court please, there is no foundation for that. We object to it on that ground. This witness doesn't know anything about what happened.

Mr. Lyon: He is the inventor.

The Court: Overruled.

The Witness: The applicator that is carrying the weight induces a traction effect on the part of the body that is stationary. The weight of the body carried by the applicator causes a stretching effect



(Testimony of Bernard H. Stauffer.)

between those areas of the body [41] that are stationary, carried by the couch.

And it is between this action and this weight of the body, carried on the couch, that you get the stretching effect or the traction in the various muscle areas.

Q. (By Mr. Lyon): I call your attention, Mr. Stauffer, to the opening paragraphs of your patent specification, wherein it is stated:

“The machine of this invention relates to mechanical means to soothe, relax, and strengthen certain of the muscular areas of the human body for the purpose of alleviating pain due to nerve stricture arising from maladjustment of certain of the vertebrae \* \* \*”

And so forth.

I am looking someplace where it mentions pelvic dip. I don't seem to be able to find it. I can't seem to lay my hand on it right now.

Just tell me, if you can, what is pelvic dip.

A. Pelvic dip in our terminology is where the pelvic structure has rolled forward in front, causing a swayback and an abdominal bulge, so to speak.

The Clerk: Plaintiff's Exhibit 4 for identification.

(The object referred to was marked Plaintiff's Exhibit No. 4 for identification.)

Q. (By Mr. Lyon): I hand you what has been identified [42] as Plaintiff's Exhibit 4 and ask you if you can describe to me what it is.

A. This is a mechanical illustration of the effect

(Testimony of Bernard H. Stauffer.)

of that motion on the human body. We have merely taken the mechanical applicator and assuming you place it under the buttocks at this point (indicating) it rocks, and it rocks it this way, it rocks it up in the front and down in the back (indicating). There is a constant rocking motion.

Assuming that the body was out of alignment, like that (indicating), which is a common ailment with the average human because, as the pelvis rolls forward it throws the weight in the back of the abdominal wall, and throws the weight off center in the knee and that is what we call the dowager hump (indicating).

Q. Now, Mr. Stauffer, this device you have, Plaintiff's Exhibit 4 for identification, has on it, does it not, various units pivoted together, intended to represent portions of a human frame, is that correct?

A. That is right. The ankle, the knee, the femur bone, the spinal column and the base of the neck area (indicating).

Q. Counting from the bottom, we have first the foot.       A. Yes.

Q. Then we have—what is next?

A. Well, the next major point of misalignment comes at the knee. [43]

Q. I am not talking—I want to give these various elements of this device a name.

The Court: Has that device been given an exhibit number?

(Testimony of Bernard H. Stauffer.)

Mr. Lyon: Exhibit 4, your Honor. These two are alike (indicating).

Mr. Harris: We have never seen this exhibit, the court please.

The Court: Come up and get a good look now.

Mr. Lyon: You can use mine.

Mr. Harris: I will simply look over counsel's shoulder as he goes through that.

The Witness: This is the foot (indicating).

Q. (By Mr. Lyon): The bottommost member is the foot?

A. Yes. Then the shinbone and the calf bone and then the thigh (indicating).

Q. No. 3 from the bottom is the thigh.

A. Thigh.

Q. The next——

A. Would be the pelvic structure (indicating).

Q. Stop with No. 4, the pelvic structure. I have taken the pelvic structure and tipped it in the clockwise direction, as it seems to want to go in Exhibit 4. Is that the condition you refer to as pelvic dip?

A. That is correct. That is our terminology for pelvic dip or pelvic tip, whichever you want.

Q. I take No. 4 unit from the bottom in Exhibit 4, the pelvis, and I move it as far to the left, or counter-clockwise, as it will go (indicating).

Explain to me what is going on when I do that.

A. When you have that you are overcoming that pelvic tip which automatically throws the weight of the abdominal area out, like this (indicating), and

(Testimony of Bernard H. Stauffer.)

lifts the rib cage. It throws the sway out of the back and it throws a better alignment in the neck area (indicating). It throws the weight in a better alignment area from the ankle through the knee, through the femur bone and through in behind the ear, which gives us good posture (indicating). That is the basic motion of the unit that acquires that.

Q. You are partner in a system known as the Stauffer System?           A. Yes.

Q. Do you care to say whether there is one basic thought that underlies the treatment known as the Stauffer System?

Mr. Harris: The court please, that is immaterial to any issue in this case.

The Court: I think we have had about all of that that we can have. After all, we are not trying the human body here, but, rather, the particular structure which has been patented. [45]

Mr. Lyon: That is right. What I wanted to point out was that this forwarding, this raising of the pelvis into its correct position by this particular motion is the basic idea which both the plaintiff and the defendant are using in their treatment of the human body.

Mr. Harris: The court please, this witness' opinion on that subject wouldn't be qualified. There is no foundation laid for that.

Mr. Lyon: I will strike the question.

Q. (By Mr. Lyon): I believe you said you are a partner in this Stauffer System?           A. Yes.

(Testimony of Bernard H. Stauffer.)

Q. Which consists of yourself and your sister, a partnership? A. That is correct.

Q. How long has that partnership been existence? A. We first started in 1938.

Q. When you made this—I notice your patent application was filed August 1, 1938. What steps, if any, after you made the invention of the patent in suit did you take toward commercializing the same?

A. Well, in November of 1938 we opened up an office to display our equipment for sale, and it later become identified as a reducting system.

Q. Will you go on and give me briefly the history of [46] the Stauffer System, from its inception up to the present time?

A. Well, we started very modestly at Third and Western here in Los Angeles. It was primarily on a basis of stepped up circulation, together with better postural, or what we term body alignment, I guess it would be——

Q. Mr. Stauffer, tell me the development of the business, did you start manufacturing and selling these tables or did you start opening salons, or what did you do?

A. We manufactured enough of the equipment to start several of our own salons, and then we manufactured more equipment to put in and establish other salons that were permitted to use the registered trade name and give the Stauffer System treatments.

Now, it expanded very rapidly at first. We had quite a number of salons by the time World War II



(Testimony of Bernard H. Stauffer.)

came along, and we expanded up until 1946. We had approximately 200 salons across the nation.

In the past 20 years—or, 19 years this month, we have given treatments to over 5,000,000 women in all 48 states, and it has become a big business. Many, many millions of treatments have been given in these salons.

Q. At my direction did your organization cause an examination of its records to be made, to determine the number of units, portable posture-rest units, such as Plaintiff's [47] Exhibit 2 for identification, and the salon type of Stauffer salon tables and the Rith-Matic tables, how many have been made and distributed?

A. Yes, we did. We instructed our manager, Mr. Teasdale, to do that.

Q. I show you a document dated November 9th and ask you if you can identify that.

A. Yes, that is the report given by Mr. Teasdale as the amount of portable home units we manufactured, together with the Stauffer salon tables and the Rith-Matic salon tables at the present time.

Q. How many of the portable units have you manufactured?

A. We have manufactured and sold—

Mr. Harris: The court please, the witness is testifying from this report. It is hearsay so far as he is concerned. We object to that question on that ground.

The Court: Sustained.

Mr. Lyon: Your Honor, I believe there is a rule



(Testimony of Bernard H. Stauffer.)

in this jurisdiction—and it is a California rule of law—that a witness can testify from a summary which is prepared under his jurisdiction.

The Court: Oh, yes, of course he can. But there is no foundation for that here.

I sustained it, without giving an elaboration of why. [48] I felt the foundation was grossly wanting.

Mr. Lyon: Well, I will lay the foundation.

Q. (By Mr. Lyon): Mr. Stauffer, in order to determine the number of units which have been sold by your partnership, would it be necessary to examine a long and voluminous account?

A. Yes, it would take quite an extensive one.

Q. Have you caused anyone in your organization to make such an examination and present you with a summary?

A. I have requested Mr. Teasdale, our general manager, to make that summary and go through the books and determine the amount that we have sold and the amount that we have manufactured.

Q. And the paper you have in your hand is his report? A. Yes, it is.

Q. But it was addressed to me instead of you, is that correct? A. That is correct.

Mr. Lyon: With that foundation, I again offer the letter—

The Court: Isn't it necessary that the summary be of things in evidence?

We use summaries repeatedly in these courts, but generally they are summaries of the evidence. They

(Testimony of Bernard H. Stauffer.)

are the pulling together or correlating of many figures or many documents. [49]

Mr. Lyon: All right.

The Court: And this is calling for a recitation of hearsay on something as to which it would be impossible to look for in this record, for the material from which to base cross examination.

Q. (By Mr. Lyon): Mr. Stauffer, will you describe the Stauffer salon tables you have manufactured and sold by Stauffer Systems?

A. We have a series of four different tables that comprise the Stauffer system of treatments. These four different tables have six different positions.

Position No. 1 is on the units that have the single paddle oscillating back and forth.

Position No. 1, we put the buttocks on the movable platform. Position No. 2, we put the shoulders on the platform.

Q. In that regard, I call your attention to a document which I am handing you. Describe that document. Tell me what it is and what it shows.

A. This shows a Stauffer System No. 1 table with the patron on the movable platform in the No. 1 position, or moving the pelvic area. This is the No. 1 position (indicating).

Q. Now, with regard to the table itself, will you describe what is shown there?

A. The table is a couch-like structure with a single [50] movable platform extending up through a slot, oscillating back and forth, in which part of the

(Testimony of Bernard H. Stauffer.)

body weight is carried by the table itself and a part of the body is carried by the movable platform.

Mr. Lyon: I will ask the clerk to mark this as Plaintiff's exhibit next in order.

The Clerk: Plaintiff's 5.

(The document referred to was marked Plaintiff's Exhibit No. 5 for identification.)

Q. (By Mr. Lyon): This illustrates the first position in the Stauffer System, is that correct?

A. That is correct.

Q. And it illustrates Table No. 1, is that correct? A. Yes, sir.

Q. Is it your opinion as a patentee and inventor of the patent in suit that Table No. 1 embodies the invention of your patent? A. Yes.

Mr. Harris: If the court please, that is the opinion of the witness. It is the province of the court to determine that and not this witness.

Mr. Lyon: I certainly think the inventor is qualified to testify as to what he thinks his invention is.

Mr. Harris: That is exactly the thing that is called upon the court to decide. [51]

The Court: The court must decide, but it is more or less like these matters of title. Any owner can testify that he is the owner or any claimed owner testifies to that and he is also allowed to testify as to the value of his property. But it doesn't mean that the court must accept his appraisal of those particular situations.

I think the same is true regarding inventors and the patents which issue upon their inventions.

(Testimony of Bernard H. Stauffer.)

Mr. Harris: There is a wide divergence of the rulings of the District Court on that very question. The weight of authority is that the witness shall not be asked questions calling upon him to interpret his own patent. That is the province of the court and not the witness.

Mr. Lyon: I disagree thoroughly. I certainly never failed to secure a ruling that an inventor can testify he thinks a certain device embodies his invention.

The Court: I think that is generally allowed.

Mr. Harris: I will be glad to furnish authorities to the court on that objection, if the court desires them.

The Court: The objection is overruled.

The Witness: May I proceed, sir?

The Court: Yes.

The Witness: Would you state that again, so I will have it clearly?

Q. (By Mr. Lyon): I asked whether, in your opinion, [52] Table No. 1 embodies the invention of the patent in suit. A. Yes, it does.

Mr. Lyon: The document, Plaintiff's Exhibit 5 just identified by the witness, is offered.

Q. (By Mr. Lyon): I show you another document—

Mr. Harris: The court please, I object to this document. There is no foundation laid this has anything to do with the patent in suit, except this witness' opinion. We object to it on that ground. It is incompetent and no foundation has been laid.

(Testimony of Bernard H. Stauffer.)

The Court: What is the document, Mr. Lyon?  
Overruled.

(The document previously marked Plaintiff's Exhibit No. 5 for identification was received in evidence.)

Q. (By Mr. Lyon): I show you another document and ask you to describe that.

A. This is Position No. 2 in the Stauffer System, and it is where the movable platform is now placed under the diaphragm or the chest area and it is—the rest of the body is, the weight is carried in another area of the couch, thus permitting a stretching action between that part of the body carried on the couch and the part of the body that is carried on the movable platform.

Q. Does that illustrate a table which, in your opinion, embodies the invention of the patent in suit? [53]      A. Yes, it does.

Mr. Harris: May I have the same objection to that last question, the court please?

The Court: You may state it now.

Mr. Harris: The objection simply is that it is calling upon the witness for his opinion as to whether something embodies the invention of his patent. I wish to have this same objection go to any question of that type.

The Court: Do you want it understood that that objection goes to all this line of testimony?

Mr. Harris: Yes, your Honor, if you please.

The Court: The court understanding that inven-



(Testimony of Bernard H. Stauffer.)

tors may give such testimony overrules your objection.

Mr. Harris: Certainly, I understand. I just wanted my objection for the record, that is all.

The Clerk: Plaintiff's Exhibit 6 for identification.

(The document referred to was marked Plaintiff's Exhibit No. 6 for identification.)

Mr. Lyon: The document just identified is offered in evidence as Plaintiff's Exhibit 6.

Mr. Harris: The court please, that is objected to, furthermore, on the ground this witness has not identified what table is shown in that exhibit.

The Court: I think that is good, Mr. Lyon.

Mr. Lyon: I will ask him that. [54]

Q. (By Mr. Lyon): What table is shown in Plaintiff's Exhibit 6?

A. This is the No. 1 Stauffer System table with the one movable platform.

Q. The same table that is in Exhibit 5, isn't it?

A. Yes, sir, the same table.

Mr. Lyon: I reoffer Plaintiff's Exhibit 6.

The Court: Received.

(The document previously marked Plaintiff's Exhibit No. 6 for identification was received in evidence.)

Q. (By Mr. Lyon): Mr. Stauffer, I call your attention to what has been identified as Plaintiff's Exhibit 2. I wish you would come down here and describe just what it is, just the same way as you described how your patent worked.



(Testimony of Bernard H. Stauffer.)

A. As the couch, in this case it is a portable, carries the weight of a body extended beyond the movable platform, and as this platform oscillates back and forth it has the mechanics of throwing the pelvis down on the back and up on the front, permitting the top half of the body to be strongly activated towards the head and the bottom more activated toward the legs and the feet (indicating).

Q. Well, concerning yourself more with the structure of the device itself, is that a muscle relaxing machine?

A. That is what—yes, it is a muscle relaxing machine. [55]

Q. Has it a couch part?

A. It has a couch part; a slot for the movable platform.

Q. And there is a slot in the couch part—

A. Yes.

Q. —opening between the two portions of the couch.

And is there a vertically directed oscillatable support for a flat rectangular applicator in that device? A. Yes, there is.

Q. Will you point it out to the court?

A. This is the applicator (indicating), flat rectangular, and these segments here are the couch structure (indicating).

Q. And there is a shaft running up there supporting that? A. Movable platform.

Q. Movable platform. Does that flat rectangular applicator move through an arc or tilt?

(Testimony of Bernard H. Stauffer.)

A. It moves through an arc. As the arc ascends it picks the weight up, permitting the top half of the body to be worked slightly like a hinge.

Q. That applicator oscillates actually the length of the couch?

Mr. Harris: The court please, these questions are very leading. Counsel is reading from the claims of the patent in [56] suit in a leading fashion, to have the witness answer yes. I think it is a leading question, and I think it is objectionable on that ground.

The Court: Sustained.

Q. (By Mr. Lyon): Tell me what happens to the applicator when you turn on the electricity.

A. The applicator moves through this arc, back and forth (indicating).

Q. Back and forth. Back and forth in any special direction?      A. It runs horizontal.

Q. Well, horizontally east and west or north and south? What direction?

A. Well, I term the motion of that arc, when the body is placed on it, the motion is from the head to the foot.

Q. In other words, it is longitudinal?

A. That is correct.

Q. Not transverse of the machine?

A. Oh, no.

Q. That is the way the machine is set up here now. Can it be converted to transverse motion?

A. Yes, it can.

Q. Will you illustrate that to the court, please?

(Testimony of Bernard H. Stauffer.)

A. By changing the direction of the couch you automatically change the direction of the motion.

Q. What you did was take the center section around and turn it around 90 degrees?

A. That is right.

Q. And put it back together again?

A. Yes.

Q. What is this device, Plaintiff's Exhibit 2 for identification, identified as in your business? Has it got a name?

A. This is called the posture-rest (indicating).

Q. Sometimes is it ever called the home unit?

A. The home unit. The home unit or the Stauffer home plan is the plan for which you use the posture-rest.

Q. Now, what is identified in your record as a Rith-Matic salon table?

A. A Rith-Matic salon table is one we sold—

Q. You can resume the stand.

A. All right. A Rith-Matic table is one that we sold outright. It was a salon table that was sold outright to anyone operating a salon, so that if they choose to operate it without a franchise they wouldn't have any access to the registered trade name "Stauffer System". In other words, we sold them a Rith-Matic unit.

Q. As a structure, how did it compare with your Stauffer franchised tables?

A. Well, there was virtually no difference. [58]

Q. And what was a Stauffer salon table. Describe it for the record.

(Testimony of Bernard H. Stauffer.)

Mr. Harris: I object, if the court please. This is all not the best evidence. The tables themselves are the best evidence, the drawings of the tables are the best evidence. To have this witness merely describe in a general way what these tables are is of no consequence in this case.

Mr. Lyon: I am asking him for a fact. He certainly knows the facts. We have pictures of them.

The Court: He may answer.

The Witness: Will you repeat the question, please?

Q. (By Mr. Lyon): I said describe a Stauffer salon table.

A. Our salon table is a large version of the posture-rest, which is constructed for commercial use.

It is built to run for long hours, which our salons operate, 14 hours a day. It is built very rugged, very heavy. But this basic principle is incorporated in it (indicating).

Q. They have a couch and so on?

A. They are identical.

Q. Describe the elements of a salon table.

A. A salon table is a couch with a movable platform extending up through a slot, in which the motion of the movable platform carries part of the weight of the body and the couch carries additional weight of the body, and the motion [59] of the platform works against that stationary part of the body.

(Testimony of Bernard H. Stauffer.)

The Court: What are you trying to prove, Mr. Lyon, by this testimony?

Mr. Lyon: You objected to my putting in an accounting of how many tables we had before I identified the tables. Now I have identified the tables.

The Court: I see what you are undertaking to do.

Q. (By Mr. Lyon): Having described a Stauffer salon table and a Rith-Matic table and a posture-rest table, you having testified, I believe, that in your opinion all three of them are manufactured in accordance with your patent, can you now give me a figure as to sales and distribution of all three of those tables?

Mr. Harris: Same objection, if the court please; no foundation laid, not the best evidence.

The Court: Sustained. Sustained on the basis there is no foundation. From what does he get the information?

Mr. Lyon: We have gone over that, your Honor. We got it from his comptroller. We asked him to run the long account.

The Court: That should be produced.

Mr. Lyon: What should be produced?

The Court: The account.

Mr. Lyon: I have it—he has it. I asked the witness [60] a while ago if he asked Mr. Teasdale to examine this long account and render a report, and he said yes.

And I asked him if he had the report and he said yes, and you said I had laid no foundation as to



(Testimony of Bernard H. Stauffer.)

what went in the accounting. I did that. I now offer as Plaintiff's exhibit next in order Mr. D. F. Teasdale's letter of November 9th, which embodies the accounting which the witness testified concerning.

The Court: Usually the foundation for that sort of thing consists of inventory or books of account, things of that kind, rather than the witness simply taking a letter from someone who has gone over the books of account.

It doesn't seem to the court to have anything to do with the question of validity, in any event.

Mr. Lyon: It is just a question of proving how many of these devices have been manufactured and sold.

The Court: What difference does that make?

Mr. Lyon: Proving commercial success.

The Court: Commercial success becomes or is of rather secondary importance in a case.

You look at it in a close case and it might shift the balance in such a case.

Mr. Lyon: I believe, your Honor, that goes to the weight, not to the admissibility.

The Court: Yes, but you can't spend a tremendous amount [61] of time on commercial success, particularly until you have established your main case which, of course, is established *prima facie* by the patent and presumption which attends it.

Mr. Lyon: It is still my understanding that it is a California rule, when the proving of a fact would require the examination of a long account and a great number of books, that the court will receive a



(Testimony of Bernard H. Stauffer.)

summary from the person who is in charge of those——

The Court: Where is the person who has made the count?

Mr. Lyon: You want Mr. Teasdale?

The Court: I don't think this man can testify to what that gentleman did.

Mr. Lyon: Except he ordered him to do it, and he is his boss.

The Court: I don't think that legally qualifies him to tell——

Mr. Lyon: I think you are probably right.

Q. (By Mr. Lyon): Mr. Stauffer, in the operation of the Stauffer System have you granted licenses to franchise holders under the patent in suit? A. Yes, we have.

Q. I believe you testified there were several hundred salons now in existence, is that correct, Stauffer Systems?

A. In excess of two hundred forty as of today.

Q. And does each of the franchise holders of those 240 [62] or more franchise holders of the Stauffer System, do they have the license under your patent in suit?

Mr. Harris: The court please, that is a legal conclusion of the witness; it is not the best evidence. The agreements themselves are the best evidence. The witness can't testify as to the legal effect of those contracts.

The Court: Sustained.

(Testimony of Bernard H. Stauffer.)

Q. (By Mr. Lyon): Do the franchise agreements mention the patent in suit?

Mr. Harris: The same objection, if the court please.

The Court: Sustained. I can see where we should have had a pretrial and made you come to agreement on a lot of these things.

Mr. Lyon: This is ridiculous, your Honor. I assure you I know the rules of evidence, but Mr. Harris is himself going to insist on the production of those franchise agreements when every one of them grants a license under the patent in suit, and he knows it.

Mr. Harris: It is not the best evidence to have this witness testify what a written contract says. That is my point, the court please.

The Court: Do you think that the contract will not back him up, so that you have a real point?

Mr. Lyon: He has no real point.

The Court: Or are you objecting simply because you have [63] a technical point?

Mr. Harris: Oh, we will stipulate these contracts don't refer to the patent in suit. I will stipulate to that.

Mr. Lyon: That they do?

Mr. Harris: That they do not. That is all I will stipulate to. But I will be glad to stipulate to that. That was the question, do they or don't they relate to the patent, specify the patent in suit, as I understood it.

The Court: Counsel, the court will undertake

(Testimony of Bernard H. Stauffer.)

generally to provide you two and a half hours a day of court time. Today you are going to have to take two hours, since we have been working here since 9:00 this morning in court.

I think we ought to adjourn now for today, but tomorrow let's start at 1:45 and we will carry through until 4:15.

Mr. Harris: Very well, your Honor.

The Court: The court will recess until tomorrow morning at 9:30.

(Whereupon, at 4:00 o'clock p.m., Tuesday, November 13, 1956, an adjournment was taken to Wednesday, November 14, 1956, at 1:45 o'clock p.m.) [64]

Wednesday, November 14, 1956, 1:45 p.m.

The Court: Are we ready to proceed?

Mr. Harris: Yes, your Honor. The court please, as we indicated yesterday at the end of last week and again on Monday of this week we served on the plaintiff subpoenas duces tecum for the production of things and documents.

I ask at this time to have those produced. Will counsel produce them for us?

Mr. Lyon: I think we will try our case in our order and you try your case in your order, Mr. Harris.

Mr. Harris: We would like to look at them.

The Court: Are you intending to use these on cross examination of the witness?

Mr. Harris: We may use them on cross exam-

ination, and we certainly want to look at them before we come to our case.

The Court: Counsel are not required ordinarily to wait until a witness is on the stand in order to look at the documentation which he subpoenaed. Can't you lodge them with the clerk so they will—

Mr. Lyon: Of course, your Honor, there will be objections to the introduction of some of these on the ground of immateriality.

The Court: Did you make any effort to obtain a view of them by any of the discovery processes of the court? [65]

Mr. Harris: I think not, your Honor, because these questions have only come out since we inspected some of the things at the plaintiff's offices about a month ago.

Mr. Lyon: We had a meeting at the plaintiff's office, I think, as Mr. Harris says, about a month ago. We laid on the table everything they asked us to produce, which we had.

The Court: When is your subpoena returnable?

Mr. Harris: Returnable at the opening of court yesterday.

The Court: To whom was it directed?

Mr. Harris: It was directed to the plaintiff, Mr. B. H. Stauffer, and it was served on his counsel as required by Rule 5.

The Court: Then those things which were called for by that subpoena should be handed to the clerk, who will give them identification numbers, so that counsel may have access to them.

Mr. Harris: Thank you, your Honor.

Mr. Lyon: So the record may be clear, I am handing the clerk what has been represented to me by representatives of the plaintiff to be all of the license agreements or franchise agreements for the Stauffer System from the dates indicated in the subpoena.

I will hand to the court reporter and ask her to copy into the record as if read by me a list of the documents [66] which I am producing.

(The above list mentioned by Mr. Lyon is as follows:)

- “Pearl Trevey, Charleston, West Virginia.
- Thelma Williams, Cincinnati, Ohio.
- Betty Skousen, Albuquerque, New Mexico.
- Walter J. Miller and Katherine K. Miller, Allentown, Pennsylvania.
- Zel Cloder, Allentown, Pennsylvania.
- Sybil Stephens, Altus, Oklahoma.
- Ethel Hatcher, Albany, Georgia.
- Betty D. Nelson, Akron, Ohio.
- Elizabeth Pearce, Oakland, California.
- Dorothy M. Marx and Verna P. Shore, Jacksonville, Florida.
- Mabel Crittenden and Louise Goins, Frankfort, Kentucky.
- Eunice Hall, Houston, Texas.
- James Ferebee and Dorothy O. Ferebee, Houston, Texas.
- Adelia Hammond, Frankfort, Kentucky.
- Rolland N. Little, Fort Wayne, Indiana.
- Mrs. M. K. Zugsmith and Mrs. M. A. Carli, Broward County, Florida.



Bernice Leadley, Jane Woods and Dorothy M. Leigh, Evanston, Illinois.

Lily Swanson and Ebba Pelascini, Eureka, Arcata, Fortuna, Calif.

Louise Bunce, Eureka, Arcata, Fortuna, Calif.

Lydia A. Heinze, Denver, Colorado.

Mrs. Carl Spoon, Durham, North Carolina.

Mary L. Herritage and C. J. Herritage, County of Nueces, not City of Bishop but including City of Alice, Texas.

Thelma Ray Thurmond, Shreveport, Louisiana.

Mary Pepe, Buffalo, New York.

Daisy Hardman, Reading, Pennsylvania.

Hazel Swore, Galveston, Texas.

Carmel E. Cameron, Gainesville, Texas.

J. D. Hurley and Burnette Hurley, Oklahoma City, Oklahoma.

Vera Greenwell and Goldie C. Kaighn, Coden, Utah.

Verna H. Whipple, Ogden, Utah.

Marie Scarnaback, Oak Park, Illinois, Skokie, Illinois.

Ellwood Thisler and Billie Fowler, Duval County, Florida.

Dr. E. R. Burkhart, Riverside and Corona, California.

Ethel H. Weber, Lexington, Kentucky.

Dorothy Maynard, San Jose, California.

Ann B. Sparks, Toledo, Ohio.

Esther L. Jennings, Lima, Ohio.

J. D. Hurley and Burnette Hurley, Oklahoma City, Oklahoma.



Mary Tuhurst Willard, Natchez, Mississippi.

Mildred N. Lakich, Dane, Wisconsin. [68]

Lucienne M. Knaus, Modesto, California.

Mrs. Estelle Semrick Buller, New Orleans, Louisiana.

Pamela Bonura and Mildred K. Marchessau, New Orleans, Louisiana.

Alice C. Webster, New Orleans, Louisiana.

Alice J. Huggins, North Hollywood, California.

Ellen S. Taylor and Margaret H. Woods, Giles County, State of Virginia.

Marie Abbott, Pasadena, California.

Edna Pasteur, Tyler, Texas.

Mrs. W. R. Lamont, Tuscaloosa County, State of Alabama.

Mrs. Ruth D. Perkins and Mrs. Audrey W. grammer, a partnership, Tuscaloosa County, State of Alabama.

Mrs. A. Badger, Vallejo, California.

Mrs. Joe A. Martin, Vernon, Texas.

John Olds and Mayme Olds, Salt Lake City, Utah.

Geneva D. Mullen, Sherman and Dennison, Texas.

Estelle Van Hartogh and A. J. Van Hartogh, Sarasota County and Manatee County Florida.

Mrs. Errol Francis, Gregg County, Texas.

Louise Miller and Edna P. Patterson, Parkersburg, West Virginia.

Lena C. Iole, Pittsburgh, Pennsylvania.

Mr. and Mrs. Lawrence Mundt, Wichita, Kansas. [69]

J. E. McMath, Phoenix, Arizona.

Mrs. Vincent L. Kirchner, Wheeling, West Virginia.

Ella Van Egten and Bert Van Egten, Palm Beach County, Florida.

Mrs. Esther Reichel and Joan Reichel, Peoria, Illinois.

Edithe Owens Smity, Macon, Georgia.

Margaret Treadwell, Macon, Georgia.

Elsie Cross, Los Angeles, California.

Mrs. Leta D. Harrison, San Antonio, Texas.

Nan Lindsay, Salt Lake City, Utah.

Velma Cole and Glen S. Cole, San Diego, California.

Irredell McIntosy, Los Angeles, California.”

I am also handing to the clerk an envelope containing the following:

A document entitled “Stauffer Reducing, Inc. price list September 18, 1956.”

It has attached to it some written matter entitled “Notes” and also a document entitled “Partial List of Home Plan Unit Parts” which is dated October 25, 1956.

I am also handing to the clerk a card entitled “Minimum Price Schedule”.

I am handing to the clerk a metal name tag reading, “Rith-Matic”, a metal name tag reading, “This Apparatus is the Property of Stauffer System”—reading in part, I [70] should say, in each case.

Another metal name tag reading “This Apparatus is the Property of Stauffer System, Inc. and

is Licensed for Use Only as Per Contractual Terms & Conditions”.

Another name tag reading “This Apparatus is Licensed Only for Use in the Stauffer System”, and a final name tag reading “This Apparatus is the Property of B. H. Stauffer Research Laboratory and is Licensed Only Per Contractual Terms & Conditions”.

That completes the material produced in response to the subpoena.

Mr. Harris: May I ask this, if the court please: Which of these name plates are produced in response to which of the paragraphs of the subpoena?

Mr. Lyon: I wouldn't know.

The Clerk: I will give these numbers after a while, when I have a chance. Will that be all right?

The Court: Yes. Mark them for identification and make them available to all counsel on both sides.

Are you ready to proceed, Mr. Lyon?

Mr. Lyon: Will those be given exhibit numbers?

The Court: The clerk will give each of them an exhibit number for identification, but those numbers we ordinarily do not read into our stenographic record until some reference is made in the record to the exhibits. [71]

They will have the clerk's tags on them so you may refer to them by their proper exhibit number if occasion arises to use them.

## BERNARD H. STAUFFER

called as a witness in his own behalf, having been previously sworn, resumed the stand and testified further as follows:

Direct Examination—(Continued)

Q. (By Mr. Lyon): Mr. Stauffer, in connection with the conduction of your business under the name "Stauffer System", was a particular routine worked out for the treatment of the patients?

A. Yes, we have a standard routine of placing them on these various tables that we have.

Q. Did that include certain specified periods of time for treatment in each position?

A. Well, we worked out what we thought was the most effective treatment and we standardized it by so many minutes on each position on all four different types of tables.

The Court: I just don't follow you, Mr. Lyon, that is, as to how this fits into the case, because the patent is not for a method.

Mr. Lyon: You are correct, your Honor. The patent is for a device, but it is the plaintiff's position that the device, due to its inherent qualities, created this new business, this new system of treating the human body. [72]

I am bringing out the extent and the ramifications of that system which is based upon this apparatus.

The Court: Will it better enable us to understand the structure?

Mr. Lyon: Well, I will go on to another subject.

Q. (By Mr. Lyon): Mr. Stauffer, are you ac-

(Testimony of Bernard H. Stauffer.)

quainted with Lawrence Mack, president of the defendant organization? A. Yes, I am.

Q. When did you first meet Lawrence Mack?

A. He applied through a letter for a franchise—at that time I think he lived in Springfield, Missouri,—and our then present manager went back and consulted with him, and I think he started his first salon, I believe it was in Toledo, Ohio. That was his first franchise and that was 1946.

Q. That the record may be clear, Mr. Stauffer, are you referring to a Stauffer System salon?

A. A Stauffer System salon, yes, sir.

Q. You granted in 1946 a franchise to Mr. Lawrence Mack for Toledo, Ohio, is that correct?

A. Well,—

Mr. Cox: Just a minute, Mr. Stauffer. I object to this question, your Honor, and to this line of questioning upon the ground it is irrelevant, incompetent and immaterial to the issues raised in this case.

The relationship between the plaintiff and the defendant [73] or any representative of the defendant corporation is wholly irrelevant to the patent infringement issue which is raised by the complaint and answer. I have, if your Honor is in doubt about the propriety of the objection, authorities in support of it.

The Court: The court has this in mind: I don't think the line of inquiry has anything to do with whether the patent is or is not invalid or whether there is or is not infringement. Those matters must



(Testimony of Bernard H. Stauffer.)

be determined from an examination of the structures, of the patent and things of that nature.

However, in these patent infringement cases we often get a prayer for attorney fees and the statute is quite clear in its language, that the plaintiff who makes out a case is entitled to those fees.

However, one of our judges disallowed fees, as a matter of course, when he found for the plaintiff, and the Circuit Court sent the case back and said, "You can't allow fees unless there was some unconscionable dealing, some over-reaching, something which would cause a chancellor in equity to think it is only just because of some aggravation, to allow attorney fees."

Now, I don't know if I have stated it with exact nicety. I think, rather, I have not. But that is the general gist of the Appellate Court's view of it.

Since that time the judges here have always allowed [74] evidence of the type which Mr. Lyon is apparently going to adduce, in order that we can examine the equities with respect to the question of attorney fees, but not to use this evidence as bearing upon the issue of validity.

Mr. Cox: I think your Honor has stated it very exactly. However, the case, the two or three patent cases I have been able to find on the subject indicate that an inquiry into the unconscionable conduct, if any, of an alleged infringement is appropriate at the time or after an infringement has been found, after the court has found on the validity of the patent and in connection with an accounting for



(Testimony of Bernard H. Stauffer.)

damages. It is not material or relevant to any issues prior to the finding of an infringement.

I will be very happy, your Honor, to pass this brief memorandum that contains two material cases to the court and counsel.

The Court: You may pass it up and I will undertake to listen to the evidence with one ear and look at your memo with one eye.

But we have the custom in this district of sending the matter of damages to a special master, in the event that damages are to be awarded.

A special master is not the person who finds on the question of whether attorney fees shall be allowed. Hence, it has been the practice here to admit the evidence so that [75] the court may know whether to make an award of attorney fees and so declare in its findings of fact, conclusions of law and judgment.

Mr. Cox: I see, your Honor.

The Court: I don't mean to say that it is appropriate upon the real issues of infringement at all, but upon damages if damages are allowed. I will look through this memorandum.

Mr. Lyon: I might add, your Honor, that evidence will show that this Mr. Mack was a franchise holder—already has shown that—and as such a licensee under the patent in suit, which means that at one time he was in a position of accepting and agreeing to the validity of the patent in suit. He was estopped—

(Testimony of Bernard H. Stauffer.)

The Court: Those are things to be argued after you get your facts in.

Mr. Lyon: I am arguing the objection in the case——

The Court: I take it that you are going to undertake to prove those things because you told me in your memo you are.

Mr. Lyon: I see.

The Court: Let's not take unnecessary time for repetition here in the courtroom because the judge makes it a point to read these memoranda, and having read them I don't think it is ordinarily necessary to get the audio on it, too.

Mr. Lyon: Do I understand the objection has been [76] overruled?

The Court: It has been overruled but the ruling has been withdrawn because counsel has handed up a memorandum which he says will change my mind. I will just take a moment to read it.

Let's not have any proceedings until I have had that moment.

In this case presently before the court we are confronted with the challenge to the validity of a patent which is about to expire, that is, it has lived more than 15 of its 17 years.

I don't want to try the case piecemeal. If we try validity and then validity is found to exist, and we adjourn while I make that determination and then convene at some later date to try infringement, and then convene again to try the issue of whether attorney fees shall be allowed, the piecemeal litigation

(Testimony of Bernard H. Stauffer.)

would still be going on after the patent has lost the vitality that was allowed by statute.

So the court is inclined to try everything this sitting, including the antitrust feature.

Mr. Cox: I certainly bow to the court's ruling, and if all Mr. Lyon is proposing to demonstrate by this line of questioning is that Mr. Mack was a franchise holder under the Stauffer System, Inc., I will stipulate to that, to cut short the examination.

The Court: I think he may show the circumstances he feels will entitle him to attorney fees.

Mr. Lyon: Is there an unanswered question?

The Court: If there was, I think you had better ask it again because it is a way back in the notes.

Mr. Lyon: All right.

Q. (By Mr. Lyon): Thereafter did Lawrence Mack ever singly or in association with others acquire additional franchises of the Stauffer System, to operate Stauffer System salons?

A. Yes, he did. He acquired Akron, Ohio, Cleveland, Ohio, Detroit, Michigan, and participated on a working agreement on the salons I personally owned in Chicago.

Q. Will you describe the relationship between yourself or your partnership and Mr. Lawrence Mack, with respect to Chicago, a little bit more completely?

A. Well, in those several salons we had, it was during a time when travel was very hard—

Q. Excuse me. At those salons in Chicago, were

(Testimony of Bernard H. Stauffer.)

they salons that were franchised out to someone else?      A. No.

Q. Or were they salons personally owned by you or the Stauffer System?

A. They were personally owned by the Stauffer System.

Q. Go forward with your answer. [78]

A. They were turned over to Mr. Mack to manage, with a working agreement. That was probably four years after Mr. Mack first started with the Stauffer System.

Q. As a manager of your salons in Chicago, would Mr. Mack have had under his care and his supervision Stauffer tables of the type which you assert in this litigation is covered by your patent?

A. Well, he had the use of all these tables in his own salons, as well as access to them in the ones that he managed for me.

Q. And any know-how that went along with those tables, would he have had access to that?

A. Well, the perpetual training and the perpetual information that we gave our salons and still do was, of course, an education itself, as to how to conduct these salons.

Mr. Mack had full access to everything that we had in the business operation.

Q. While he was still operating salons as a franchised holder, did Mr. Mack, to your knowledge, make any plans or arrangements for divorcing himself from the Stauffer System?

A. Well, he opened up—while he was still man-

(Testimony of Bernard H. Stauffer.)

aging my salon in Chicago he opened up a system in the same building, in competition to my operation, at 30 West Washington.

He opened up additional salons in the New York area, predicated on the same principle. [79]

Q. Did he take with him, when he opened these new salons, any of your own employees?

A. He took practically all our employees but two people.

Q. Do you happen to be acquainted with the manager of the Slenderella salon—

Mr. Lyon: You may correct me if I have the wrong address. I believe it is 610 South Broadway, Los Angeles?

Mr. Cox: There is a salon at that address.

The Witness: I don't know the present manager, no.

Q. (By Mr. Lyon): Do you happen to know the name of the woman who is the manager of Slenderella Systems of California Incorporated?

A. I know her, but I can't think of her name. But she was—

Q. She has changed her name, hasn't she?

A. Yes, she has. She was an employee at one time of the Stauffer System in Chicago.

Q. Now, is it not a fact there was previous litigation between you and Mr. Mack?

A. Yes, sir.

Q. And is it not a fact that that litigation ended up in a settlement contract by which the parties, as a certain date in 1953, exchanged mutual releases?



(Testimony of Bernard H. Stauffer.)

A. Yes, sir.

Q. I show you a document which is Exhibit A to [80] Defendant's Second Request for Admissions, which you have admitted is genuine, as a record in this case, and ask you if that is the document you just referred to?      A. Yes, sir.

Q. I note that this document recites that:

“ . . . in further consideration of a release of the undersigned executed by the persons and corporations hereinafter named under even date herewith, have, jointly and severally, remised, released and forever discharged, . . . ”

That indicates to me there was another document running from Lawrence Mack, Mr. Blanchette and the people listed in this document, to you or Stauffer System, Inc., by way of a general release.

Can you produce any such document?

A. I don't think we have been able to find it to this date.

Q. But do you have an independent recollection of such a document?

A. Yes, there was such a document.

Q. It was in general terms like most of these releases are?      A. Yes, sir.

Q. Perhaps the court would be interested in knowing about the circumstances concerning the disappearing of your [81] safe. Would you like to make that of record?      A. We have had—

The Court: This doesn't seem to bear upon unconscionable acquisition of a knowledge of the structure or of the design and so on.



(Testimony of Bernard H. Stauffer.)

It seems to go more to an unfair competition feature, which is not raised by the pleadings in this case.

Mr. Lyon: Well, deliberate infringement is always considered by the courts in matters of this type, and this shows that the president of the defendant was fully aware of the structures, made so as an officer, acting as a trusted employee, and with that situation in mind, while charged with management of our own business in Chicago, he was building a salon right next door in the same building, preparing to go into competition.

If there was ever a case of deliberate and willful infringement, this is it.

The Court: I wouldn't raise any object to that, but I don't see how it would make any difference if he cracked this safe or not.

Mr. Lyon: Oh, no, your Honor. I am just pointing out this is a lost document because someone stole our safe which had all our valuable documents in it. Just showing the reason for not producing our copy of the release.

The Court: Well, the release would not tend [82] to show, would it, anything that would bear——

Mr. Lyon: It is out of order, I will admit. I should be proving this release at another time, but while I had this witness on the stand and while we are talking about Lawrence Mack, it was convenient to prove the existence of another release running from Mack to Stauffer, on the basis of which

(Testimony of Bernard H. Stauffer.)

I will argue later that no evidence prior to the general release should be admitted in this case.

Mr. Cox: I just want to refer briefly, your Honor, to the analogy of Mr. Lyon's position.

On one hand he accuses the president of the defendant corporation of unlawful, illegal and improper conduct. In the same breath he averts to a general release back to that same individual, together with the corporation he represents, presumably and on the face of it two or three years subsequent to the alleged improper conduct.

I suggest that further demonstrates the impropriety of this entire line of investigation, your Honor .

The Court: Of course, a release always refers to present rights. It doesn't refer to future rights.

Mr. Lyon: That is right.

The Court: I have opened the door to this line of questioning, which I have now sought to some extent to close again, not all the way, hoping that counsel would limit it to the time intervening between the execution of the release [83] and the present day.

Mr. Cox: The court will have noted it all antedates the period of the release, their relationship which has just been inquired into.

Mr. Lyon: I am through with that line of questioning, except I would like to have this document received in evidence and I would like to make my record as to the fact that the lost document is lost because someone stole our safe.

(Testimony of Bernard H. Stauffer.)

I certainly am not accusing anybody having anything to do with this case of stealing our safe. But we did lose our safe and a great number of our valuable documents.

The Court: All right. Go ahead and prove it.

Q. (By Mr. Lyon): Go ahead and explain the situation about the safe, Mr. Stauffer.

A. We had not one but four or five robberies, and in one they backed a truck up and carried off a 600-pound safe, including most of our valuable papers. That has been our problem here with some of these documents that they requested.

Q. Whenever we can't find a document, we just assume it was in the safe?

A. Yes, that is correct.

Q. You are making that assumption with respect to the release that ran to you in this case?

A. That is correct.

Mr. Lyon: I will offer as Plaintiff's exhibit [84] next in order a photostatic copy of the Stauffer System, Inc.—Mack et al agreement of September 25, 1953.

The photostatic copy is an unexecuted copy, but I believe it will be stipulated by both parties the same was executed by Mr. Stauffer as president of Stauffer System, Inc.

Mr. Cox: No objection. That is so stipulated.

Mr. Lyon: What exhibit number will that be?

The Clerk: This will be Plaintiff's Exhibit No. 15. The other exhibits are marked Plaintiff's Exhibits 7 through and including 14.

(Testimony of Bernard H. Stauffer.)

(The exhibits referred to were marked Plaintiff's Exhibits 7 through 14, for identification.)

The Court: This one is admitted into evidence.

(The exhibit referred to, marked Plaintiff's Exhibit 15, was received in evidence.)

[See Book of Exhibits]

Mr. Lyon: You may cross examine.

#### Cross Examination

Q. (By Mr. Harris): Mr. Stauffer, you are not a Doctor of Medicine, are you?

A. No, I am not.

Q. You have never been licensed to practice medicine in the State of California or elsewhere, have you?      A. No, I haven't.

Q. You are not an engineer, licensed to [85] practice engineering in the State of California, are you?      A. No, I am not.

Q. You have had no academic or technical background in either engineering or medicine, have you?

A. No, sir.

Mr. Harris: I produce three drawings, one dated 7-22-55, one dated 7-19-55, and one dated 8-20-55, all stamped "Stauffer System, Los Angeles 4, California," which I ask be marked for identification as Defendant's Exhibits A-1, A-2 and A-3.

(The exhibits referred to were marked Defendant's Exhibits A-1, A-2 and A-3 for identification.)

Mr. Harris: I might say, if the court please, these are drawings which Mr. Lyon delivered to me

(Testimony of Bernard H. Stauffer.)

in response to our request to him for a drawing or drawings of the present machine made by the plaintiff in this case.

Q. (By Mr. Harris): Mr. Stauffer, I show you these three drawings which have been marked for identification, and ask you if you recognize those as drawings of the plaintiff's salon-type machine?

A. That is correct.

Q. Which one, the Rith-Matic or the Stauffer machine?

A. They are one and the same; and I testified on that yesterday.

Q. They have the same mechanism, do they, [86] those two machines?      A. That is correct.

Q. And is this mechanism substantially the same as that embodied in the physical exhibit, the home unit machine, Plaintiff's Exhibit 2 for identification, which was here in the court yesterday?

A. They are both a couch, they both have the slot coming up through, permitting the paddle to operate in a tilting manner. The belt and the pulley arrangement is different.

Q. Is the motion——

A. The motion is identical.

Q. Is the motion of the pad or seat or applicator or paddle, as you call it, the same in all three types of machines?      A. Yes, they are.

Mr. Lyon: At this point, your Honor, I think if it isn't already admitted, I would like to have Exhibit 2 introduced in evidence.



(Testimony of Bernard H. Stauffer.)

The Court: I don't recall what it was. What is 2?

Mr. Lyon: This home unit over here in the floor (indicating).

Mr. Harris: We have no objection.

The Court: We have all been proceeding on the theory it is in evidence.

Mr. Lyon: Mr. Harris called it Plaintiff's [87] Exhibit 2 for identification, which gave me some concern in that regard.

Mr. Harris: We have no objection.

The Court: It is now received, if it has not been received before.

(The exhibit referred to, marked Plaintiff's Exhibit No. 2, was received in evidence.)

Mr. Lyon: It was not so marked.

Q. (By Mr. Harris): Now, Mr. Stauffer, I have placed an enlargement of the drawing, Sheet 1 of the drawings of the Stauffer patent in suit, on the blackboard in front of you.

I propose to proceed to have you compare certain features of the machine illustrated by the drawings, Defendant's Exhibits A-1, A-2 and A-3, with the mechanism shown in the drawing of the Stauffer patent in suit.

First, these drawings do not show—the drawings I am referring to now are Defendant's Exhibits A-1, A-2 and A-3—any couch, do they? There is no couch actually shown in these drawings?

A. Well, these were drawings that, let us say,



(Testimony of Bernard H. Stauffer.)

were shop drawings of the mechanism only as it is put together in our shop. So what you have is strictly the mechanism and not the unit as a whole.

Mr. Lyon: We will stipulate there is no couch shown there, Mr. Harris.

Mr. Harris: Certainly. [88]

Q. (By Mr. Harris): And referring particularly to the drawing marked Exhibit A-3 for identification, where does that mechanism set, or how is it disposed with relation to the couch?

A. This unit here—(indicating)—

Q. Excuse me. By that you are referring—

A. This tubing that comes around in this manner (indicating) supports the entire mechanism. That bolts right up under the table and permits this section here (indicating) to extend up through the slot in the table, permitting the identical action on all three units.

Q. Excuse me. By this mechanism that is to be bolted to the top of the table, you are referring to the tubular construction marked with 8 on the drawing, is that correct?

A. That is correct, yes.

Q. So the two ends of that tube, as shown in this drawing, are bolted underneath the top of the couch?  
A. That is right, yes, sir.

Q. So that the support which carries a paddle, marked 2 on the drawing, extends up through this slot in the couch, is that correct?  
A. Yes, sir.

Mr. Lyon: Well, so the record may be clear, this

(Testimony of Bernard H. Stauffer.)

is really a cross member like that (indicating), that receives the padding. [89]

The Witness: This is the casting of which the padding goes on (indicating).

Q. (By Mr. Harris): Will you please mark on the drawing with a pencil what you have referred to as "this" with A?

A. (Witness complies.) Casting.

Q. No, that is enough, thank you, Mr. Stauffer. And in the table shown by this drawing, Defendant's Exhibit A-3, how high above the table does the paddle No. 2 on the drawing extend? How high is it above the top level of the couch?

A. Well, by the time you get the padding on there, which is something I can't tell you right now, it is computed to be the same, identical, as the original.

Q. What do you mean "the same as the original"?

A. Well, our—that is the original drawing you have displayed there.

Q. The same height?

A. The same motion is, from here to the top of this paddle will be identical, as to the distance there (indicating).

In other words, the axis here, through which that travels, is the same as the axis on this one in its travel (indicating.)

Q. Now, you say there is a pad in the actual tables that fits on top of this member that is marked 2 on this drawing?

A. Yes, sir.

(Testimony of Bernard H. Stauffer.)

Q. Would you please sketch that pad in with a pencil [90] I have here?

A. Well, it would be something like this (indicating).

Q. Is that a flat pad or is it a convex pad?

A. It is a flat pad very—exactly as we have on the home unit; flat and square pad.

Q. So that this salon-type table, which is illustrated in Defendant's Exhibit 3, is hung from the top of the couch and is not supported on an independent base, as shown in your patent in suit, that is correct, is it not?

A. That is right. We have carried it from the top, rather than from the bottom support.

Q. This arm that extends upwardly and which carries the paddle 2 in this drawing (indicating), Exhibit A-3, that arm has a pivot at its lower end, which is marked 24, does it not? A. Yes, sir.

Q. In that table there is no connecting rod connected to the arm at any point between the pivot 24 and the pad 2, as is the connecting rod 28 connected to the support 20 in your patent in suit?

A. No, other than we have connected it to the same shaft, and we have extended it down below, instead of up above, for machining purposes primarily. [91]

Q. It is a different construction, however?

A. It is a different position in which it is taken. The end result is identical, but the method of arriving at it has been changed.

Mr. Harris: If the court please, I move to strike

(Testimony of Bernard H. Stauffer.)

the last answer of the witness as being non-responsive and volunteered.

The Court: Granted.

Q. (By Mr. Harris): Now, referring to the drawing, which has been marked as Defendant's Exhibit A-1 for identification, the part numbered 31 on that drawing is the motor, is it not, the electric motor? A. Yes, sir.

Q. The part numbered 18 is a small pulley, is it not? A. Yes, sir.

Q. And that small pulley, in the mechanism shown by the drawing, is adapted to be connected to a large pulley 16 by a belt 19? A. Yes, sir.

Q. The large pulley 16 is carried on an idler shaft 14, is it not? A. Yes, sir.

Q. On the other end of which is mounted a second small pulley 18, is it not? A. Yes, sir.

Q. And that latter small pulley through a belt is connected to and drives a larger pulley, which is mounted on a shaft marked 6 on the drawing?

A. Yes, sir.

Q. By the belt 20. A. Yes, sir.

Q. And that shaft 6 is a transverse shaft, which extends transversely across the unit, and is mounted in bearings close to each end of the shaft, is it not?

A. Yes, sir.

Q. And mounted on that shaft at center or approximately at the center is an eccentric or cam, is it? A. Yes, sir.

Q. And that cam, in turn, is connected through

(Testimony of Bernard H. Stauffer.)

a connecting rod to the upwardly extending arm that carries the paddle 2, is that correct?

A. That is correct.

Q. In this drawing, Defendant's Exhibit A-1 for identification, there is thus a gear reduction between the drive shaft of the motor and the idler shaft 14, by reason of the difference in pulley sizes, differences in the sizes of the pulleys 18 and 16, is there not?

A. Yes, sir.

Q. Again there is a second gear reduction between the idler shaft 14 and the cam shaft or eccentric shaft 6, [93] through the difference in sizes of the pulleys 18 and 20, is there not?

A. Yes, sir.

Q. There is no such double gear reduction in your patent in suit, is there? There is only a single gear reduction, which is from the drive shaft of the motor 50, the small pulley mounted on that shaft, to the large pulley 48, which, in turn, drives the cam shaft 42.

A. We merely acquired the same speed by using the lower speed motor.

Q. There is a lower speed motor used in which ones?

A. In the first ones, where there is only one stage of reduction.

Q. But there is only one stage of reduction in your patent in suit?

A. That is right, yes, sir.

Q. Did you ever build any machine exactly as is illustrated in the drawings of your patent in suit?



(Testimony of Bernard H. Stauffer.)

A. When we first started we built them just exactly like that (indicating).

Q. You built only ten or fifteen?

A. Oh, no. The first year or two that is all we built, is that.

The Court: You mean ten or fifteen or your total output? [94]

The Witness: No, when we first started to build them they were built on this basis (indicating).

The Court: By "this basis" you motioned toward Figure 1, 2 and 3 of Patent No. 2,240,679?

The Witness: Yes. I don't know just how long we built them that way, but there was considerable time that we built them in that manner.

Q. (By Mr. Harris): Mr. Stauffer, you recollect, do you not, the taking of your deposition on December 21, 1955, at the offices of Mr. Cox, who is associated with me here in this case? You remember that, do you not?      A. Yes, sir.

Q. You remember, do you not, that as shown at page 84 of that deposition I asked the following questions and you gave the following answers:

"Q. Did you, the partnership or the corporation, ever make or have made for you any table as is shown in that patent?

A. "Yes, the original table was just like that.

"Q. How many tables were so made that were just like the construction in there?

"A. I would say ten or twelve, something like that.



(Testimony of Bernard H. Stauffer.)

“Q. And then the construction was changed, was it? [95]

“A. The motion of the table wasn't changed. The mechanics that approached the motion were changed.”

You remember so testifying, do you not?

A. Yes, sir, and that is just about—I stated then ten or twelve, and the first year or so we didn't build too many of these tables, Mr. Harris.

I was just estimating it, and that is about the size of it.

Q. As you so testified.

A. I beg your pardon?

Q. As you so testified in your deposition.

A. Yes, sir.

Q. What was the speed of the motor or motors in those first tables that you built, in accordance with your patent in suit?

A. As I remember, we used 1150 r.p.m. motor.

Q. What is the motor speed in the motors which you use in your present day— A. 1750.

Q. Is that true in your Stauffer salon table, in your Rith-Matic salon table, and in your home unit table?

A. The manufacturing of the motors today is primarily all 1750 revolutions.

Q. Are the motors in all three types of tables, which I have just enumerated, the same? [96]

A. They are the same, 1750, yes, sir.

Q. I might ask you, Mr. Stauffer, with respect to these drawings which you have before you, De-

(Testimony of Bernard H. Stauffer.)

pendant's Exhibits A-1, A-2 and A-3, and with respect to the height of the pad or paddle 2 above the couch top, when that mechanism is installed in a couch how does that correspond with or differ from the height of the pad or paddle above the couch top in the home unit, Exhibit 2 in evidence here?

A. Well, I would say there is some variation of the height in some of our models. The length of travel is quite an item in the arc that it travels through, and we have always tried to maintain three-quarters of an inch in the mechanical design.

Q. Three-quarters of an inch overall?

A. In the travel of the platform.

A. A total movement of three-quarters of an inch, is that correct?

A. That is right, yes.

Q. Can we summarize your testimony with regard to your three types of present tables, that is, the home unit, the Rith-Matic salon and the Stauffer salon tables in this way: That the nature of the movement of the pad or paddle in each of those three tables is substantially the same?

A. Yes, sir.

Q. And that is true as to all tables which you [97] have manufactured or sold, is it not?

A. We have tried to maintain that same motion, yes, sir.

Q. Referring you again to the drawing of your salon type table, which is marked Defendant's Exhibit A-3 for identification, and particularly to the

(Testimony of Bernard H. Stauffer.)

upstanding arm A, which you have marked as "A" on the drawing, it is a fact, is it not, that in the operation of this device the arm A moves in an arc about the pivot 24? A. Yes, sir.

Q. And in moving in that arc it moves in substantially equal distances on both sides of the vertical, taken through the pivot point?

A. It can be adjusted through 11 to suit any angle that you wish, by shortening or lengthening this threaded nut in there (indicating), which you will see was made for that specific purpose.

Q. But actually when you operate these tables in your own salons, the arm or support A does move through an arc on both sides of the vertical, substantially as in this home unit, Plaintiff's Exhibit 2, which is in evidence here in court?

A. Yes, sir.

Q. And that is an arc about a total of eight degrees, is it not, four degrees on each side of the vertical? [98]

A. Primarily, we try to always get it over in this angle, to bring it in just up or a little past that, depending on this adjustment here (indicating).

In other words, in this adjustment, it should be adjusted in such a manner that the arc goes further to one side than it does to the other.

Q. But it does go on both sides of the vertical, does it not? A. Yes, it does.

Q. That is true in the home unit, Exhibit 2 which is here in evidence, is it not?

(Testimony of Bernard H. Stauffer.)

A. That is right, yes, sir.

Q. All the tables which you have made and used commercially have that type of movement in the operation of the pad or paddle?

A. Basically, they are stronger on one side, but they do go past the vertical point.

Q. In none of these tables which you have actually used have you had the support for the applicator or pad, which is marked "A" on this drawing before you, move through a small arc on only one side of the vertical?

A. Would you state that again, please, sir?

Mr. Harris: May it be read, please?

The Court: Yes.

(The question was read.) [99]

The Witness: When we first started that was the idea, but as time proved we could extend it over into the other, why, we did extend it past that top point.

However, we have primarily kept to one side for the major motion of the paddle.

Q. (By Mr. Harris): You are familiar with the fact, are you not, that in your patent in the drawing and in the specification of the patent there is described a device in which the support 20 moves only on one side of the vertical, through a small arc of about ten degrees, from about minus fifteen degrees to minus five degrees from the vertical?

A. Yes, sir, I am familiar with it.

Q. So far as your patent is concerned—we are not speaking now about your commercial machines

(Testimony of Bernard H. Stauffer.)

in any way—but so far as your patent is concerned, that small arc of movement is a very important factor, is it not? A. It is, yes, sir.

Q. And the purpose in the device described in the specification and illustrated in the drawings of your patent in suit, the purpose in limiting the travel of the seat 18 to an arc, which is on one side of the vertical, is to establish a better motion of the seat as it is applied to the human anatomy, is it not? A. That is correct, yes, sir. [100]

Q. As a matter of fact, Mr. Stauffer, you regard that motion applied through the travel of the seat, in your patent in suit, as it is applied to a body? In other words, that motion to and fro, running through that degree of angle we referred to, has the essential factors or features of your patent in suit, does it not?

A. I would consider it important in the treatment process, yes, sir.

Q. But you do consider it as the essential factor in your patent in suit, do you not?

A. Well, I would say one of them.

Q. Referring again to the speed of movement of the pad or paddle in your commercial machines, illustrated by Plaintiff's Exhibit 2 in evidence and Defendant's Exhibits A-1, A-2 and A-3 for identification, is the speed of the movement of the pad in those machines in any way critical in obtaining the results claimed for in your patent, in the specification of it?

A. Well now, it depends upon what you say—



(Testimony of Bernard H. Stauffer.)

what you mean when you say "critical". Critical within a hundred cycles a minute, yes. Critical within four or five cycles a minute, no.

Q. In other words—

The Court: I don't see anything in the patent with reference to the speed. [101]

The Witness: Yes, we identify it as 130, your Honor.

The Court: You do? Where?

Mr. Harris: I was coming to that, if the court please.

The Court: All right.

Q. (By Mr. Harris): In other words, if the speed of the paddle is too fast you don't get the results stated in the specification of your patent, do you? A. No, sir.

Q. If the speed, on the other hand, is too slow you do not get the results claimed for in your patent application? A. That is correct.

Q. What are the maximum and minimum speeds permissible to obtain the results set forth in the specification of your patent in suit?

A. I think you could extend it 20 cycles a minute either direction and have less effectiveness than you would at the 130 cycles a minute, as we set as normal.

Q. 20 or 30 cycles per minute from what speed?

A. From 130, which is the one that we refer to in ours.

Q. You have a copy of your patent in suit before you, Mr. Stauffer? A. No, sir, I don't.



(Testimony of Bernard H. Stauffer.)

Q. I place Exhibit 1, the patent in suit, before you. [102] Will you kindly point out to the court any statement in your patent in suit as to the speed or movement of the pad or applicator 18?

A. I guess I was mistaken. I was reading one of the other patent applications. This one does not so state that I can find.

Q. Mr. Stauffer, you testified, I believe, yesterday that in the operation of the home unit, Plaintiff's Exhibit 2 in evidence, the motion of the pad or paddle is from the head to the foot of the table.

Which is the head and which is the foot of that table?

A. Well, I would say it depends upon the way the body laid on it. Normally, we consider the head towards the slight angle of degree, as being placed with the—may I illustrate here?

Q. Yes, certainly.

A. We consider the pitch being this way (indicating), as the head going this way. Or you can change it around and put the head on this area (indicating) and have—depending on which way the body is placed on it.

Normally, in the treatment process that we have considered we like to have them be placed with the head in the direction of the angle, slight angle of the platform.

Q. But so far as your commercial tables are concerned, your No. 1 table, exemplified by Exhibit 2 here, and the [103] Rith-Matic table, the mechanism which is shown in these drawings, De-

(Testimony of Bernard H. Stauffer.)

fendant's Exhibits A-1 to A-3, in the ordinary commercial operation of those tables, all three of them, the user or patient can lie on the table with his head at either end, can he not?      A. Yes.

Q. And the same thing is true of the table shown in the patent in suit, is it not?

A. Yes, sir.

Q. I place before you, Mr. Stauffer, Plaintiff's Exhibits 5 and 6, which are these cards. Those merely show an artist's conception of the Stauffer tables, do they not?      A. Yes, sir.

Q. They are not intended to be mechanical drawings showing the tables in correct proportion or in correct size?      A. No, sir.

Q. And they do not accurately show the tables, actually, do they?

A. They are, just as you say, artist's drawings.

Q. Neither shows any of the operating mechanism of the table, does it?      A. No, sir.

Q. Except the pad or applicator above the table top?

A. It merely shows the position of the body while on the applicator on the couch. [104]

Q. You were present yesterday in court, were you not, and saw the running of the motion picture, the film which is marked as Plaintiff's Exhibit 3?      A. Yes, sir.

Q. It was a fact, was it not, that in that motion picture in one sequence the model was seated on the machine, seated on the paddle of the machine, with her back to the camera? Do you recall that?

(Testimony of Bernard H. Stauffer.)

A. Yes. It was impossible to photograph the body while it was down, lying on the unit, so they had to set the model upright so we could show the expansion of the vertebrae and the motion of the unit.

Q. Is that actually one position of use of your commercial machines?

A. It could be, but normally we don't recommend it.

Q. In other words, if a patient wanted to sit on it, she could?

A. Let's say it has never been one of the Stauffer Systems.

Q. And that would be one position of use of the machine illustrated in your patent in suit, would it not?

A. I beg your pardon? Would you state that again, please?

(The question was read.)

Q. (By Mr. Harris): In other words, you could [105] sit on the paddle of the machine illustrated in your *patient* in suit equally well and have the treatment, could you not?

A. Well, we wouldn't recommend it. It has never been used as such in our salons.

Q. Now, in any of these machines of yours, the home unit, exemplified by Plaintiff's Exhibit 2, and the Rith-Matic salon table, or the Stauffer salon table, you could put your feet on the pad or paddle while the machine is operating, to exercise or massage the bottoms of the feet, could you not?

(Testimony of Bernard H. Stauffer.)

A. We exercise the legs, but not necessarily the bottom of the feet.

Q. But it could be so used?

A. Yes, sir, it could be so used.

Q. The same is true of the machine illustrated in your patent in suit, is it not? It could be so used?

A. It could be, yes, sir.

Mr. Harris: If the court please, we have not had an opportunity to examine the documents and things which counsel have produced here, and I would respectfully request a short recess, if I may have one, to permit us to just see briefly what those things are, because I think I may wish to cross examine Mr. Stauffer as to some of them.

The Court: All right. Short recess.

(Whereupon, a recess was taken from 3:01 p.m. to 3:20 p.m.) [106]

The Court: Are you ready to proceed?

Mr. Harris: Yes. Thank you, your Honor.

Q. Mr. Stauffer, all of your relations with Lawrence Mack, directly or indirectly, were prior to September 25, 1953, were they not?

A. Well, approximately, I would say, that was the date.

Q. The date of the release which is here in evidence?

A. Yes, sir.

Q. Mr. Stauffer, there have been produced here, in response to the subpoenas of the defendant, directed to you and your counsel, certain name plates which have been marked as Plaintiff's Exhibits 7 to 11, inclusive.

(Testimony of Bernard H. Stauffer.)

First of all, I shall display these to you. Do you personally have any knowledge of the use or extent of use of those name plates or name plates like them?

Mr. Lyon: I object to this line of questioning as not proper cross examination.

The Court: Just what does it go to? The name plate, certainly, will not establish the validity or invalidity of the patent.

Mr. Harris: They go only to this, your Honor, the question of marking. In the plaintiff's complaint he has alleged that he has marked all machines made under this patent with the patent number. It goes simply to that question, which we suggest is proper cross examination. [107]

The Court: All right. You may proceed with it.

Do you remember the question, Mr. Stauffer?

The Witness: I only knew them in a general manner.

Q. (By Mr. Harris): Referring first to the name plate marked Exhibit 6, was that name plate or ones like it ever used on any machine built or operated by you or under your direction?

A. That was the only one of the Stauffer System tables that we sold, yes, sir.

Q. The one that was entitled "Rith-Matic"?

A. Yes, sir. That was the one that has been sold.

Q. During what period of time were name plates of this type actually put on the tables that you sold? A. I couldn't answer that.



(Testimony of Bernard H. Stauffer.)

Q. You don't know whether any were ever put on the tables that you sold, do you?

A. I am sure that practically all of them, to my knowledge, had the "Rith-Matic" name on it, if they were sold.

Q. You don't know whether they had this particular name plate on, though, do you?

The Court: I can't recall, counsel. Probably the patent law requires a marking of some sort, but I don't recall it.

Is it like the copyright law or trademark law?

Mr. Harris: It requires marking, yes, your [108] Honor. There are two points on this.

First, it is unlawful under the patent law to mark something patented which is not patented. It is unlawful, it is illegal. It is a subject for a *qui tam* action.

Of course, in this case we are not contending now or we shall not contend that Mr. Stauffer is guilty of any crime, whether he marked or didn't mark his tables, but——

The Court: Or for any civil penalty.

Mr. Harris: Or for any civil penalty in this case, that is correct. But it has the further point, that there is a requirement in the patent law that a patentee shall mark his tables, which point goes to the question of damages. However——

Mr. Lyon: If I may be heard on that. There is no such requirement.

The law is that if a patentee has failed to mark, then he is limited to damages—in recovering dam-



(Testimony of Bernard H. Stauffer.)

ages, to a time after the defendant knew of the patent. Certainly, this defendant knew of the patent.

Mr. Harris: At any rate, that goes to the question of damages. We are not to that point in this case, anyway.

But there is the further point—and this is the important point I am driving it—and that is, if Mr. Stauffer made and used these machines over a period of years and did not mark, he knew himself [109] that this patent didn't cover his machines, which is our contention, of course.

So I think the question of whether he marked or not is germane to the issues in the case.

The Court: I appreciate now what question you are getting at.

Mr. Harris: Thank you.

The Court: I didn't know whether we had a marking requirement in patent as in copyright or not.

Mr. Harris: It isn't the same type of marking requirement. It is the requirement only, as Mr. Lyon stated, it goes to the recovery of damages by the plaintiff.

Q. Now, referring to Plaintiff's Exhibit 8, has that marking plate ever been used on any tables made, used or sold by you or under your direction?

A. That is one that I think—now, I am not positive on this, but generally I would say we used that on our own personal property we did not sell.

Q. In other words, the salon tables you leased or rented to franchise holders, is that correct?

(Testimony of Bernard H. Stauffer.)

A. That is right. That was our own personal property and we never extended it out of our hands.

Q. Those were tables which have been referred to here as tables leased or licensed by these franchises that you granted?

A. These were the ones that were licensed to the [110] franchise and many times they would have this one, which is identified as our property, together with another one that I don't see here.

Q. Well, "this one"—

A. Very often they had the combination here.

Q. This name plate, Exhibit 8, says on its face, "This Apparatus Property of Stauffer System".

A. That may have been one we used on, let us say, some of the equipment that wasn't patented.

Now, whether that went on No. 1, I don't know, but this is normally the one that went on where we said it was our property and it still carried the serial number.

Q. You don't mean the serial number, do you?

A. I mean the patent number.

Q. There is a serial number on that one, also?

A. The patent number.

Q. On "that one", you are referring to Exhibit 11?      A. Yes.

Q. Over what period of time was this Exhibit 11 used?      A. I wouldn't have any idea.

Q. Referring to Exhibit 9, Plaintiff's Exhibit 9, do you recognize that as being a label used on your tables?

(Testimony of Bernard H. Stauffer.)

A. Yes, I would say that we used that.

Q. On the No. 1 tables?

A. I would say we used it on the No. 1 tables.

Q. Over what period of time?

A. That I don't know.

Q. And referring to Exhibit 10, is the same true as to that exhibit?

A. Well, on this one I don't know what table it went on. Apparently, it didn't go on the table with the patent, because the patent number isn't on it. We may have used it on another table.

Q. The fact is, is it not, Mr. Stauffer, that prior to the middle of 1953 you never used the patent number of the patent in suit on any tables made, used, leased or sold by you, directly or indirectly?

A. To the best of my knowledge they all had them on.

Q. During what period of time?

A. Well, from the time we received our patent.

Q. Until the present?

A. Until the present time. You haven't got the old Rith-Mo—this is the Rith-Matic, but the old style label apparently isn't here.

Q. You are familiar with the table, the salon type Stauffer table which was exhibited to me, to Mr. Hudson Cox at your plant on October 16, 1956, with Mr. Lyon and Mr. Teasdale? You are familiar with that table, are you not?

A. Yes, I think I saw it in the back, yes.

Q. You saw us there, did you not? [112]

A. Yes, I did.

(Testimony of Bernard H. Stauffer.)

Q. You know, as a fact, that that table had no patent number on it, did it?

A. I don't know that, no. I think it was brought up out of the factory and still being in our possession didn't have the complete number put on it.

Q. Up to the present time have you personally ever seen any of the defendant's tables?

A. No, sir, I have not.

Q. And prior to this suit, the filing of this suit, neither you nor anyone in your organization had drawings or sketches of construction or mechanism of any of the defendant's tables, did you?

A. Not drawings, no.

Q. You had no information as to the detailed construction of the defendant's table or tables, did you?

A. We had information as to how it worked.

Q. The type of treatment it gave, and that is all?

A. No, the method in which the table functioned.

Q. By that you mean the movement of the paddle or pad?

A. By that I mean the similarity in the motion of the pad in relation to the slot, in relation to the position that the body was put on the movable platform, et cetera.

Q. And that was the only information you had, was it not?      A. Yes, sir. [113]

Q. During your direct examination yesterday, Mr. Stauffer, you rearranged the home unit table

(Testimony of Bernard H. Stauffer.)

that was here in court, Plaintiff's Exhibit 2, to give a transverse motion to the pad and paddle.

That cannot be done with any of your other tables, can it?

A. No, sir, not the salon tables.

Q. Referring back to these name plates, Plaintiff's Exhibits 7 to 11, inclusive, who made those name plates for you?

A. I think Kennedy Name Plate is usually the one that makes our name plates.

Q. Have they been making them throughout the years for you?           A. Yes, sir.

Q. Do you have any record of your purchases of name plates?

A. Well, I imagine we have for the last five or six years, but not for the 19 I am sure.

Q. I think during your direct examination you stated that in or about 1946 you had franchised some two hundred salons to use the Stauffer System, as you refer to it, in all 48 states. [114]

A. I think between '46 and '48 it ran to approximately two hundred salons, yes, sir.

Q. But in '46 you had a very substantial number of such salons operating, did you not?

A. Well, we had considerable, yes.

Q. And I think you said on direct examination that as of now you have approximately two hundred franchised salons, is that correct?

A. In excess of that, yes.

Q. Prior to the advent or the entry of the defendant Slenderella System, or any of its related



(Testimony of Bernard H. Stauffer.)

companies, into this business of providing passive exercise by mechanical couch-like machines, your Stauffer System and its use was the only system in use at the time, and prior to that time, the advent of Slenderella, for this type of thing, was it not?

A. It was the only one that used it mechanically. There were others that used it electrically.

The Court: I don't understand just what you are saying.

The Witness: Relaxacizor has an electrical apparatus they claim exercises muscles, puts electricity in the tissues.

Mr. Harris: Did your Honor wish to inquire further?

The Court: Well, what is the contact with the body, electrical current? [115]

The Witness: Yes, sir, it is a sinusoidal current that strictures the muscles. They claim it is an exercise.

Ours at that time was the only extended one that exercised it mechanically.

Q. (By Mr. Harris): So far as a couch-like table upon which a patient or user reclines, to take the treatment, your Stauffer System was the only system in use prior to the advent of Slenderella, was it not? A. Well, in a large way, yes.

The Court: That calls for a pretty big conclusion, I should say. He can answer as to whether he knows of any, but in your opening statement yesterday you suggested that there were several,

(Testimony of Bernard H. Stauffer.)

at least, which had reached the stage of being patented—

Mr. Harris: Oh, well,—

The Court: —so they might have been invented and used.

Mr. Harris: Yes, but I am speaking about business competition.

Q. In reducing or exercising salons for ladies yours was the first, was it not, in which they used a couch-like structure with an applicator, a movable applicator? A. To my knowledge, yes.

Q. You have been familiar with that business all over the United States, from the very beginning, have you? A. Yes, sir. [116]

Q. If there had been any others, you would have known it, would you not? A. I may have.

Q. As a matter of fact, as of today *Slenderella* is your only competition in this type of business, is it not?

A. Oh, no, there are quite a number of them.

Q. I am talking simply about business predicated upon a couch upon which a patient or a customer reclines to have a treatment by means of a movable applicator of some kind.

A. I know of three others.

Q. What are they?

A. Well, there is *Slim Line*. There is one in Texas that is operating on the same basis out of Dallas. And one operating in Toledo.

Q. What sort of a machine does *Slim Line* use?

A. It is mechanical, operating in a similar man-

(Testimony of Bernard H. Stauffer.)

ner as this. That is what I have been informed. I have never seen it myself.

Q. Does it have a couch on which the patient or customer reclines to have a treatment?

A. I understand it is a couch?

Q. Have you ever seen it? [117]

A. I have never seen it.

Q. Have you ever seen the one issued from Texas?

A. No, sir, I haven't seen any of these, other than just told exactly how they operate.

Mr. Harris: No further cross examination.

#### Redirect Examination

Q. (By Mr. Lyon): Mr. Stauffer, do the Stauffer salon tables, which you lease or rent to your franchise holders, bear serial numbers?

A. Yes, sir.

Q. And where is the serial number applied?

A. It is applied on this name plate.

Q. So then does that indicate to you anything as to whether or not each Stauffer table that has been distributed to the public had such a name plate?

A. It would have to in order to keep our records straight.

Q. A minute ago Mr. Harris suggested that you didn't have any other competition at the present time, except Slenderella.

Isn't it a fact that there are numerous people in the United States who own their own Rith-

(Testimony of Bernard H. Stauffer.)

Matic tables, who are offering reducing service to [118] the public, along the lines of the Stauffer System? A. Yes, sir.

Q. There is Marie Van Dusen in Las Vegas for one, isn't there? A. Yes, sir.

Q. And Mrs. Exely, whom you sued for using the name "Stauffer Tables", who was another one, wasn't she? A. Yes, sir.

Q. We have another instance of the same down in New Orleans, do we not? A. Yes, sir.

Q. In other words, those are just the ones that have been called to my attention. Are there any others?

A. Oh, I am sure there must be eight or ten more around the nation of a similar nature, where they own Rith-Matic tables and they don't operate under the Stauffer System franchise, but they are operating their own business.

Q. And we are having a little trouble keeping them from using the good name Stauffer, aren't we? A. Yes, sir.

Q. Mr. Stauffer, Mr. Harris suggested—I believe you agreed with him—that you are not a graduate chemist. But do you have any training in chemistry?

A. Oh, yes, I have the standard training in both high school and a short time in college. [120] I have about 35 years of research.

Q. What, if anything, have you done with respect to blood chemistry?

A. I was associated with a man who had exten-

(Testimony of Bernard H. Stauffer.)

sive training in that field, and when we developed the Stauffer System, and we were trying to arrive at the speed in which the fatigue acids were developed, we started at very high frequencies and it was necessary to make blood analysis to determine the amount of fatigue acids, to know when we would get the motion at the highest rate, yet without producing any fatigue acids. I have a world of experience in that respect.

Q. With respect to this question of mechanical engineering. Since 1938 you have been in the manufacturing business, haven't you?      A. Yes.

Q. You have been the head of a rather extensive manufacturing plant, is that right?

A. Yes.

Q. And you have designed a good deal of that machinery, have you not?

A. Primarily, all of our designs were my designs.

Mr. Lyon: That is all.

Mr. Harris: No further examination, if the court please.

The Court: Call the next witness.

(Witness excused.) [120]

The Clerk: You have some exhibits.

Mr. Lyon: Are you going to offer 7 through 11?

Mr. Harris: I don't know what the court's pleasure is on my offering the exhibits during my opponent's case.

Mr. Lyon: I will offer them, too. They have



plaintiff's numbers. I have no objection to them.

Mr. Harris: We have no objection to them.

The Court: What is the foundation for them?

Mr. Lyon: These are name plates he cross examined the witness on.

The Court: They are received into evidence.

(The objects heretofore marked Plaintiff's Exhibits 7 to 11, inclusive, were received in evidence.)

Mr. Lyon: I don't believe A has been received.

Mr. Harris: I might at this time, if it is proper procedure, offer into evidence Defendant's Exhibits of the same letters, the drawings, Exhibits marked A-1, A-2, and A-3 for identification.

Mr. Lyon: No objection.

The Court: Received.

(The documents heretofore marked Defendant's Exhibits A-1, A-2 and A-3 were received in evidence.) [121]

### DOUGLAS B. NICKERSON

called as a witness on behalf of the plaintiff, having been first duly sworn, was examined and testified as follows:

The Clerk: Be seated, please.

State your name in full, please.

The Witness: Douglas B. Nickerson.

The Clerk: How do you spell your last name?

The Witness: N-i-c-k-e-r-s-o-n.

The Clerk: Your address?

The Witness: 345 Blythe Road; B-l-y-t-h-e. In Pasadena.

(Testimony of Douglas B. Nickerson.)

Mr. Lyon: At this time, if the court please, I offer as Plaintiff's Exhibit 16 a print entitled "Exercising Machine for Slenderizing Systems, Inc." This was furnished to me by Mr. Harris at my request for a print illustrating the Slenderella machine.

Mr. Harris: No objection. We stipulate those are the facts.

The Court: It is received. This is the accused structure?

Mr. Lyon: Correct.

(The document heretofore marked Plaintiff's Exhibit 16 was received in evidence.)

Mr. Lyon: I next offer a print entitled "Sacro-Matic Inc." slenderizing machine, which has the [122] same history. It was furnished to me by Mr. Harris on my request for a drawing of the Slenderella Inc. slenderizing tables.

May it be stipulated, Mr. Harris, that you have informed me, and it is a fact, that there have been two types of tables manufactured and used by the defendant, and that the minor differences between the two are illustrated by these two separate drawings?

Mr. Harris: I think you misspoke yourself, counsel, but I am very glad to stipulate these two prints, Exhibits 16 and 17, illustrate tables which have been used by the defendant in this action.

Mr. Lyon: I see.

Mr. Harris: The defendant doesn't manufacture or sell anything.

(Testimony of Douglas B. Nickerson.)

Mr. Lyon: I will accept that. We offer these two, 16 and 17, in evidence.

The Court: Received.

(The documents heretofore marked Plaintiff's Exhibits 16 and 17 were received in evidence.)

Mr. Lyon: May I have 16, please, Mr. Clerk?

I had better qualify my witness, first, I guess.

#### Direct Examination

Q. (By Mr. Lyon): Mr. Nickerson, what is your technical education? [123]

A. I graduated from the California Institute of Technology in 1940 as a Bachelor of Science in mechanical engineering.

Q. Are you a registered engineer in the State of California?

A. Yes, I am a registered mechanical engineer.

Q. Is this the first patent infringement case in which you have ever testified?

A. No, it is not.

Q. It is the third, isn't it? A. Second.

Q. What is your present position?

A. I am assistant chief engineer for research and development for Hydro-Aire Incorporated, subsidiary of Crane Company.

Q. Prior to that, what was your position? Not at Hydro-Aire, but your previous employment.

A. I was previously employed by Aerojet Engineering Corporation in Azusa, as senior engineer.

(Testimony of Douglas B. Nickerson.)

Q. What is your experience, your personal experience with respect to patents?

A. Well, I have read some. I testified in a case for Lyon and Lyon on a latching mechanism.

Q. What I meant more than that is, do you have patents in your own name? [124]

A. I have a patent issued to me. I have an application for several more, and another application which is under secrecy.

Q. You are an inventor of at least several patents, is that correct?      A. That is right.

Q. And you have had occasion to read and interpret patents, is that correct?

A. That is correct.

Q. As a matter of fact, didn't I give you about 80 of them just the other day, which you were supposed to go home and study?

A. That is right.

Q. At my request, have you made a study of Plaintiff's Exhibit 16?

A. Is this Plaintiff's Exhibit 16 (indicating)?

Q. That is.      A. Yes, I have.

Q. Would you explain to the court what is illustrated in Plaintiff's Exhibit 16, as far as essential operating mechanisms? You don't need to worry about the frame and things like that.

A. Plaintiff's Exhibit 16 illustrates a table which is so arranged that it may oscillate, and an applicator supported from that table which also can oscillate. [125]

(Testimony of Douglas B. Nickerson.)

Do you want more detail than that? These are the essential elements of it.

Q. Well, you might point out the motor and the belts and things like that, and driving mechanism.

A. Each element is driven by an electric motor through a belt drive, and the cam is driven by the motor drive.

A connecting rod transmits the motion from the cam to a link, and the link in turn transmits the motion to a pad or table, as the case may be.

Q. Now, confining ourselves to the right-hand portion of the table, and particularly to Section Line CC, do you find a slot in the table?

A. There is a slot in the table, yes.

Q. Do you find an arm or pair of arms extending up through that slot?

A. That is right, there is an arm, or in this case there is a pair of arms up through that slot, which are connected together.

Q. I see. Those arms support applicators, is that correct

A. Well, applicators or pads.

Q. All right: Are those arms pivoted?

A. The arms are pivoted about a fulcrum point.

Q. I see. Now, what have you done in the way of making [126] a simplified model of the device shown in this?

A. At your request I made a Keno-Matic model to illustrate the motion of the table and the applicator.



(Testimony of Douglas B. Nickerson.)

The Court: What do you mean by "Keno-Matic?"

The Witness: A Keno-Matic model is one that illustrates the motion but not the forces.

The Court: Counsel, do I correctly understand that this litigation now involves only Claim 1 of the patent, of the Stauffer patent?

Mr. Lyon: That is quite correct, your Honor.

Mr. Harris: Yes, your Honor.

The Court: All right.

Mr. Lyon: I ask the clerk to identify this as Plaintiff's Exhibit 18.

(The object referred to was marked as Plaintiff's Exhibit 18 for identification.)

Q. (By Mr. Lyon): I now hand the witness Exhibit 18, and ask if that is the Keno-Matic model referred to?      A. That is the model.

Q. I have got the right one?

A. You have got the right one.

Q. Will you point out to the court what happens in that model and compare it to what is happening in Stauffer patent No. 2,240,679, or what is disclosed in that patent?

Mr. Harris: If the court please, there is no foundation [127] laid with respect to the patent, so far as this witness is concerned.

The Court: I think that is correct.

Q. (By Mr. Lyon): Have you read the patent in suit?      A. No, I haven't.

Mr. Harris: He hasn't even studied it, apparently.

(Testimony of Douglas B. Nickerson.)

Q. (By Mr. Lyon): I told you to do it.

A. I read the claims, but not the whole patent.

Q. All right. Explain what this does then. First, tell me what this model is.

A. This model demonstrates, or, illustrates the table here (indicating). This blue item illustrates the table (indicating).

Q. Just a second so the record will be clear. Plaintiff's Exhibit 18, is this the Keno-Matic model of Plaintiff's Exhibit 16? A. That is right.

Q. Now you can explain what the model shows.

A. The model shows in blue the table, and in red, the vertical red member is the applicator (indicating).

And the motion of the model illustrates the motion of the applicator and the motion of the table.

Q. Now, this vertically extending red member (indicating), is that the member that is indicated—in the table supports the applicator or pad? [128]

A. That is correct.

Q. Now, in the drawing, Exhibit 16, does this red member extend through a slot in the table?

A. Yes, it does.

Q. Actually, in the drawing, Exhibit 16, there are two such shafts running upwardly, is that correct?

A. They are actually one piece; they are two legs of the casting.

Q. Two legs. So you could say that picturewise you might take this as a section cut through here and looking this way (indicating). A. Yes.

(Testimony of Douglas B. Nickerson.)

Q. When I say "this" I mean this Keno-Matic model, Exhibit 18.

A. Keno-Matic model represents an illustration of the machine.

Q. I hand you now what has been identified as Plaintiff's Exhibit 17, and ask you to compare that with Exhibit 16 and——

First I will ask you, did you make a Keno-Matic model of Exhibit 17?      A. Yes, I did.

Q. You did?      A. Yes.

Mr. Lyon: I will ask the clerk to identify this as [129] plaintiff's next in order.

The Clerk: 19.

(The object referred to was marked Plaintiff's Exhibit 19 for identification.)

Q. (By Mr. Lyon): I will ask you if that is the Keno-Matic model of Plaintiff's Exhibit 17?

A. Yes.

Q. With those four exhibits before you, will you point out what is shown in Exhibit 17 and how that is illustrated in Exhibit 19?

A. The elements are essentially the same. In Exhibit 19 we have the upper structure, which I assume is a pad. The pad is not shown in Exhibit 17. But this is shown in green and has the same reciprocating motion.

Q. You mean the table is green, is that right?

A. The table—what I assume is the table. It is not defined on the drawing as a table.

And the upper, the vertical member or what is

(Testimony of Douglas B. Nickerson.)

assumed to be the applicator is also illustrated and has its reciprocating motion.

Q. It is in red, is that right?

A. It is in red.

Q. Compare the motion of the two red members of Exhibits 18 and 19.

A. The motion of the two members is very similar. [130] A slight difference exists because in Exhibit 18 the connecting rod moves about a horizontal line. Whereas, in Exhibit 19 the line is canted from the horizontal.

Q. What does that result in, a slight change in the motion?

A. That results in a slight change in the motion.

Q. Does that result in a change in which the motion is slightly greater off center in one direction than the other?

Mr. Harris: That is objected to, if the court please; leading and highly suggestive.

The Court: Overruled. It is, of course, but these presentations by experts in this type of matter are almost counsel on the witness stand, anyway.

I think that we are going to get the result of the leading interrogation whether we have it in the court room in that form or not.

Mr. Harris: I agree, your Honor.

Mr. Lyon: I will withdraw that question.

Q. I will ask you to describe the motion and how it differs in these two Keno-Matic models.

A. Well, with respect to the vertical member or applicator—

(Testimony of Douglas B. Nickerson.)

Q. That is all I am interested in.

A. —the Exhibit 18 will have an essentially pure [131] sine motion about the vertical.

The Court: A what?

The Witness: An essentially pure sine wave motion about the vertical.

The Court: How do you spell that "sine?"

The Witness: S-i-n-e.

The Court: I want to be sure we have our record correct.

Q. (By Mr. Lyon): By that you mean it will transverse an arc substantially the same—

A. On either side of the vertical.

Q. On either side of the vertical?

A. That is correct.

Q. Is that true of Exhibit 19?

A. Exhibit 19 will not be quite evenly distributed about the vertical, due to this distortion, due to the connecting rod not being horizontal.

Q. Due to the slight angle which the connecting rod bears to the horizontal?      A. Right.

Mr. Lyon: You may cross examine.

Excuse me. Have these Keno-Matic models been received in evidence?

The Court: I don't think they have been received.

The Clerk: No, your Honor.

Mr. Lyon: I would like to offer them. [132]

Mr. Harris: They are objected, if the court please, on the ground there is no foundation laid



(Testimony of Douglas B. Nickerson.)

they correspond to what is shown in these drawings; they are incompetent and irrelevant.

Mr. Lyon: If I haven't asked the witness that, I will ask him.

The Court: All right.

Q. (By Mr. Lyon): Did you do the best you could to make a Keno-Matic model which would represent and would depict Exhibits 16 and 17?

A. Yes, I did.

Q. And as a matter of fact, you made one mistake, didn't you, and had to go back and correct it?

A. That is correct.

Q. Do, in your opinion, Exhibits 18 and 19 respectively make a Keno-Matic showing of the action of Exhibits 16 and 17?

A. In a qualitative way, yes.

Mr. Lyon: I renew my offer of Exhibits 18 and 19.

Mr. Harris: Same objection.

The Court: Overruled. They are received.

(The objects heretofore marked Plaintiff's Exhibits 18 and 19 were received in evidence.)

### Cross Examination

Q. (By Mr. Harris): Mr. Nickerson, these Keno-Matic models, as you call them, Exhibits 18 and 19, are not made to scale, as shown in these drawings, are they?

A. They are scaled from the drawing, yes, sir.

Q. Let's look at that. What scale?

A. As close as I can ascertain I attempted to

(Testimony of Douglas B. Nickerson.)

make them full scale. The drawings show a scale on them, or a dimension, and working from that information I attempted to make the models to be life size or full scale.

Q. That is with respect to what parts of the model?      A. With respect to the motion.

A. With respect to the motion.

Q. Well, there is no motion shown on the drawings, is there?

A. It is indicated by the nature of the drawings.

Q. Are the parts on these models made to full scale?

A. As close as I could ascertain from scaling a drawing, yes.

Mr. Lyon: Except for the length of the table, you don't mean to indicate that?

The Witness: Excuse me. The mechanism is made to scale. I foreshortened the table, obviously.

Q. (By Mr. Harris): What mechanism are you referring to in these models? [134]

A. The cams, the connecting rods and the linkages.

Q. And the relationship between those cams, connecting rods and linkages, and the top of the table?      A. Yes.

Q. Just how did you go about doing that, Mr. Nickerson?

A. I laid the drawings out on a drafting table, and in one case I took the scale factor from the drawing.

(Testimony of Douglas B. Nickerson.)

In another case the drawing was dimensioned, and I used that as a basis.

And by means of a pair of proportional dividers laid out the length of the various linkage elements. From the layout of the linkage elements I cut out pieces of plywood to simulate them.

The location of the fulcrum point and the length of the connecting rods, as shown here, and the length of the applicator bar are taken—scaled from the drawing by proportional dividers.

Q. How did you cut them out of plywood, was it with a bandsaw or something?

A. Yes, by bandsaw.

Q. Then did you check the dimensions of those parts after you cut them out against the drawings again?

A. I want to make one point clear at the outset. The outside, contrary to these parts, is not the pertinent part. The distances between fulcrum points are important. [135]

These were carefully laid out with these dividers and spotted in with a drill press, so that the distances are appropriate, as close as I could determine from the drawings.

Q. But the question is, did you check the parts, dimensions of the parts against the drawings after you had made the parts?

A. Yes, sir, by the same method as I did before.

Q. There is in the defendant's table, illustrated by the drawing which is Plaintiff's Exhibit 17—strike that and I will start over again.

(Testimony of Douglas B. Nickerson.)

Which view, if any view on this drawing, did you use in making one of the Keno-Matic models?

A. The view shown as Section BB and Section CC.

Q. And what is the Section BB in this drawing?

A. The Section BB shows the mechanism which oscillates what I think is the table. It isn't shown as a table on the drawing, so I can't identify it positively.

Q. Did you ever see any table such as is shown in this drawing, Plaintiff's Exhibit 17?

A. No, sir.

Q. You say that the part that you have just described, which I take it is the part shown in Section BB on the drawing, is used to vibrate or oscillate the whole table? A. It appears to be so.

Q. The top of the table or the table including the [136] frame?

A. It appears, the top—to oscillate the top only, if this is a table; it isn't shown in this drawing clearly. If we could use the other one, it illustrates the table, and we could be more clear.

Q. You refer to a table as being the blue member illustrated in these or included in these Keno-Matic, or, the Keno-Matic, Exhibit 19.

What part of that is the table? Is it the whole thing or is it the top of it, or what are you referring to?

A. Well, this blue member (indicating) illustrates or is intended to represent the table structure.

The table structure is a frame and it includes

(Testimony of Douglas B. Nickerson.)

brackets, on which a motor is carried and on which the applicator fulcrum is carried, and the applicator cam is carried.

Q. And this mechanism shown by the Section BB in the drawing, Plaintiff's Exhibit 17, which is the mechanism shown on the left in the model, Exhibit 18, that has nothing to do with the operation of or the motion of the applicator shown in the middle of the exhibits, does it?

A. Exhibit 17 has nothing to do with Keno-Matic model 18.

Q. Excuse me. We are working on the wrong model. We will get the right model.

I put before you the model which is Exhibit 19, which, [137] as I understand it, you say corresponds to the drawing, Exhibit 17?

A. That is correct.

Q. All right. Now, my understanding is that this mechanism on the left of the model, Exhibit 19, is taken from the Section BB on this drawing (indicating)?

A. That is correct.

Q. And that mechanism has nothing whatever to do, does it, with the operation of the red object, the upstanding arm in the middle of the model?

A. That is correct.

Q. Why did you include that in this model, if it has nothing to do with the operation of the applicator arm?

A. I was asked to make a Keno-Matic model of the machine, not of a specific part of it.

Q. This does not show all the machine, does it?



(Testimony of Douglas B. Nickerson.)

A. It shows the—well, it is a representation of the motions through which the machine goes, and all of the motions.

Q. Now then, in making the parts of the model, Exhibit 19, which are in the center of the model, the upstanding red piece of wood here (indicating), with the rod connected to it in blue (indicating), what did you use, what view of the drawing, Exhibit 17, did you use to make that from?

A. Section CC. [138]

Q. Section CC? A. Yes (indicating).

Q. How did you get the length of the connecting rod for the model in that mechanism?

A. By a set of proportional dividers, and multiplying the length by four. Section CC is indicated as a scale of one-quarter of an inch to an inch.

Q. In talking to you about this model making job, Mr. Nickerson, did Mr. Lyon indicate to you that he wanted these models, so far as possible, to have an applicator arm which moved on one side of the vertical?

A. We discussed this one side of the vertical to some extent, although I can't say that he asked me to lead the model in one direction or another.

We discussed the results of making the model and of studying the drawing.

Q. A small difference in the location of the pivot point for the red upstanding applicator arm makes quite a difference in the arc of movement of that arm relative to the vertical, does it not?

A. Yes, it will make some difference.

(Testimony of Douglas B. Nickerson.)

Q. And the same thing is true as to the location of the pivot point for the little crank that you have put on here in lucite? A difference in the location of that pivot point, even in a small amount, changes materially the arc [139] arrangement in which the red applicator arm moves, does it not?

A. To a lesser degree, yes.

The Court: I don't see these fine points of whether it does or does not are involved here in determining whether Claim 1 of the patent is or is not infringed.

You might enlighten me, if I am just dense in not getting your point, but I can't see what you are driving at because it doesn't seem that Claim 1 relates at all to this subject, as to the fine points of it.

Mr. Harris: This is merely cross examination because I don't think this model corresponds with the drawing. I am attempting to bring that out. It doesn't—

The Court: You may go ahead. I just didn't see that even if you traveled the entire length of this road it would be getting us anywhere in our lawsuit.

Mr. Harris: Well, it is a question, your Honor, of what type of movement the plaintiff has in his patent, what kind of movement the defendant has in its tables. That is one of the main issues in the case.

The Court: Well, it says the “\* \* \* applicator is adapted to tiltingly move, and means to oscillate said applicator axially \* \* \*” and so on.

(Testimony of Douglas B. Nickerson.)

It doesn't get down to the refinements that either of you have been laboring in the examination of this witness. [140]

Mr. Harris: Well, the specification——

The Court: If it does, I just don't see it there.

Mr. Harris: The specification is very plain in this patent, if the court please. The specification, with regard to the movement of the vertical support 20 in the patent, or the upstanding support, it says that “\* \* \* the degree of movement ranges from about minus 15 to minus 5 degrees from the vertical, thereby causing the manipulator to swing through a range of 10 degrees, during which interval the seat or manipulator support 20 at no time passes the vertical, \* \* \*”

This patent teaches at no time does this support for the seat or applicator come up to the vertical itself, always on one side of the vertical in a range as shown in the dotted lines in the drawing of the patent, and as I have read here in column 2, top of column 2 on page 2 of the patent.

In other words——

Mr. Lyon: That, I submit, pertains entirely to Claim 2 of the patent and has nothing to do with Claim 1.

The Court: You have been reading this first part of the patent and the small portion I read to you is indicative of the incapability of what you were going into was from the claim, and the suit, of course, is upon the claim.

Mr. Lyon: That is correct. [141]

(Testimony of Douglas B. Nickerson.)

Mr. Harris: But the court please, the law tells us we must interpret the claims in the light of the specifications and the drawings. We must refer to the specifications and drawings to interpret the claim.

Whereas here, the plaintiff has limited his specification and his drawing by the amendment he made to them, to be very specific in this type of movement we are just talking about now.

It is our position that by doing so he is estopped now from contending, from any interpretation of these claims to cover any other movement, any broader type of movement.

Mr. Lyon: I would like to see some authority that holds there is any estoppel ever created by an amendment to the specification, as distinguished from an amendment to a claim.

Mr. Harris: Well, that is a matter of argument, of course.

The Court: You mean you are challenging the existence of such. You wouldn't really like to see it.

Mr. Lyon: Judge, you put the words right in my mouth.

Mr. Harris: No, if the court please, there is an argument in here, there will be an argument in here as to just how the devices operate, and whether or not these models that the plaintiff has produced do correctly show the operation of defendant's [142] structure, because we shall contend they do not. I wish to cross examine this witness at some greater length on this.

(Testimony of Douglas B. Nickerson.)

The Court: My instituting this colloquy was simply to get myself educated as to the direction or what you were aiming at in the cross examination, because I was beginning to fail to follow you.

Mr. Harris: Thank you, your Honor. I am very pleased to have an opportunity to speak to it.

The Court: These little colloquies are not to be taken as indicative of the court having a view one way or another, as to the ultimate merits of the litigation.

Mr. Harris: I understand. I am going to be quite a little while longer with this witness. It is now after the time your Honor indicated you wished to close. I don't wish to keep your Honor here. If you wish to recess now, we will be glad to.

The Court: If this is an opportune time, we will do so. I thought we would stay a little later, because as usually happens we taken a recess contemplating ten minutes and some lawyer comes in and the recess extends to thirty. I think we got by today with about twenty, however.

Mr. Harris: Whatever your Honor's pleasure is, of course.

Mr. Lyon: May I ask, Mr. Harris, about how [143] much longer Mr. Nickerson will be on cross examination.

He has another job he would like to get back to. He would like to have some idea when he can get back.

Mr. Harris: I think it will be fifteen or twenty minutes more, certainly.



(Testimony of Douglas B. Nickerson.)

The Court: If it is that brief, let's take the fifteen or twenty minutes now.

The Witness: Thank you.

Q. (By Mr. Harris): In making these models you have I notice indicated some notches on the right hand blue connecting rod member of Exhibit 19.

What do those correspond to?

A. Those correspond to the notches shown in Section CC for that same member, right here (indicating).

Q. And from Section CC, how do you tell the length of the connecting rod arm? It is broken in Section CC, is it not?

A. The length of the connecting rod is shown in section, in Section CC. In other words, you can scale it. This is a true view, taken looking at the side view of the connecting rod (indicating).

Q. In Section CC the connecting rod is actually broken there by lines, is it not,—

A. That is correct.

Q. —to indicate that something else is in [144] there besides what is shown? It is a foreshortening, isn't that the conventional way—

A. Possibly so. However, as closely as I could ascertain the axis distance is the same on CC—is represented the same, excuse me, on Section CC as it is in the plan, of the top view of the mechanism.

Q. Now, the fact is that in this machine shown by Plaintiff's Exhibit 17 there is not one, but there

(Testimony of Douglas B. Nickerson.)

are two vertical arms on the top of each of which is an applicator pad? That is a fact, is it not?

A. This is a fine point. Actually, there are two legs of a common arm. They are all one single weldment.

See, this one is welded on here and this one is welded on here (indicating). It is a single element of the machine; however, there are two legs.

Q. And on the top of each of those two legs there is a separate pad support, is there not?

A. In this drawing there are no pads shown.

Q. But a pad support?

A. Well, possibly. There is a——

Q. I call your attention to Section CC, the item that is indicated in the small square as "S.A. D." on the top of the arm. That is the support pad, is it not?

A. I have no way of knowing that. I assume it is.

Q. There is nothing in this model, which [145] is Exhibit 19, to indicate that the two pad supports, which are parallel, as you just described them, may be operated in unison or oppositely, is there?

A. Yes, there is on the drawing, Exhibit 17. The drawing indicates that both of these vertical members are welded to a common tube.

Q. So then it is your conclusion that both of these members, the vertical members, do not operate in unison? A. I assume so.

Q. And that they cannot operate independently in opposing operation? A. That is correct.

(Testimony of Douglas B. Nickerson.)

Q. Do you find any indication on that drawing, Exhibit 17, of any timer to control the sequence of operations of that mechanism? A. No, sir.

Q. And in this mechanism, illustrated by the drawing Plaintiff's Exhibit 17, there are two slots in the top of the table, are there not?

A. Exhibit 17 has no slots because it has no table.

Q. Oh, you don't consider—

A. This is only a structure around on which you might bolt a table.

Q. There is no table shown in this drawing at all? A. Not on 17, no sir. [146]

Q. And then in Exhibit 19, do you indicate any table there?

A. We represent the table structure, if you will, what is assumed to represent the table if it were shown on the drawing.

Q. But you cannot tell from Exhibit 17 whether the defendant's structure has one slot or two slots, can you? A. No.

Q. You can tell, however, that it does have two applicators in the structure in the center?

A. This is a fine point. There are two legs on a common member. Now, whether that represents two or not, I don't think—I don't know.

I don't think it does. If I designed a structure and it had two extensions on it, it would still be the same piece of mechanism.

Q. But that is because you have never seen one

(Testimony of Douglas B. Nickerson.)

of these actual tables, according to this drawing, and therefore you don't know, is that correct?

A. Well, I have never seen one of these tables, and from the drawings I can't state whether or not it has two or one pad, actually.

Q. Now, going to the other drawing which is Exhibit——

Mr. Lyon: 16.

Mr. Harris: I don't find any marking on this drawing. [147]

The Witness: Here it is (indicating).

Q. (By Mr. Harris): Oh, yes. Exhibit 16, which you say corresponds to Exhibit 18,—is that correct?

A. I think that is right. Yes, this corresponds to 18.

Q. Now, in the construction shown in the drawing, Exhibit 16, it definitely shows two slots through which the upstanding applicator arms extend, does it not?      A. Correct.

Q. And it shows two sets of double applicators, one on each of those arms, does it not?

A. That is correct.

Q. And those applicators in the defendant's machine, shown by Exhibit 16, are not on the longitudinal axis of the machine, are they?

A. Pardon me. Would you repeat that again?

Q. Well, I will just restate it. Neither of the applicators or pads, nor sets of applicators or pads in the mechanism shown in Exhibit 16 are on the longitudinal center line of the table or machine?

A. That is correct.

(Testimony of Douglas B. Nickerson.)

Q. Now, from this drawing, Mr. Nickerson, can you tell us how this machine operates, whether these pads or paddles operate together or whether they operate in opposition, or how they operate?

A. It is not possible to determine from this drawing.

Q. Also, there is no timer shown in this drawing, is there?

A. I didn't look for that. Let's see. No, no timer here, so far as I can ascertain.

What is that (indicating)? Well, unless it is this control switch (indicating). There is a control switch shown.

Q. And in the making of the model, which is Exhibit 18, the same things apply, do they not, which you said applied to the making of the model, Exhibit 19, insofar as the location of the various pivot points and the length of the members is concerned?

A. That is correct.

Mr. Harris: No further cross examination, your Honor.

The Court: Redirect?

Mr. Lyon: A couple of questions.

#### Redirect Examination

Q. (By Mr. Lyon): Mr. Nickerson, in the making of these models, Exhibits 18 and 19, did I give you any instructions about the necessity of being very careful?

A. Yes, you did. You wanted to be very careful to truly represent the motion. [149]



(Testimony of Douglas B. Nickerson.)

Q. And after you had delivered these models to me, did I ask you to make a re-examination of the drawings to be sure they were actually correct, insofar as you could make that correct?

A. This was the intent. We discussed the motion, as represented on the drawings, and as shown on the model.

Q. When you delivered the model to me in the first place, the model of Exhibit 18, you had this crank arm on the left—

A. Connecting rod.

Q. —this connecting rod on the left (indicating) on the right, and the one on the right on the left (indicating)?

A. That is correct.

Q. How did you discover that mistake?

A. By rechecking the drawing.

Q. How come you were rechecking the drawing?

A. You asked me to.

Mr. Lyon: That is all.

Mr. Harris: Nothing further, your Honor.

The Court: May this witness be excused?

Mr. Harris: Certainly.

(Witness excused.)

The Court: Will 1:30 be a convenient time tomorrow?

Mr. Lyon: 1:30? [150]

The Court: Yes.

Mr. Harris: Yes, your Honor.

The Court: The court is recessed until tomorrow morning at 9:30. This case until 1:30 tomorrow.

(Whereupon, at 4:30 o'clock p.m., Wednesday, November 14, 1956, an adjournment was

taken to Thursday, November 15, 1956, at 1:30 o'clock p.m.) [151]

Thursday, November 15, 1956; 1:35 p.m.

The Court: Are you ready to proceed?

Mr. Lyon: The plaintiff has concluded its prima facie case.

Mr. Harris: First, if the court please, I produce a certified copy of the file wrapper and contents of the Stauffer patent in suit, No. 2,240,679, which is offered into evidence as Defendants' Exhibit B-1.

The Court: It will be received.

(The document referred to was received in evidence and marked Defendants' Exhibit B-1.)

[See Book of Exhibits.]

Mr. Harris: Next, if the court please, I produce a certified copy of a document entitled "Search Sheet" with regard to Patent 2,240,679, which I ask be marked as Defendants' Exhibit B-2.

I offer that in evidence as Defendants' exhibit of the same designation.

Mr. Lyon: On what basis?

Mr. Harris: This indicates the field of search of the Patent Office in connection with the application for the Stauffer patent in suit.

Mr. Lyon: I don't know whether you can prove anything that way. This, your Honor, is merely the examiner's notes in the file. It is nothing that was communicated to the defendant. [155]

It is not part of the prosecution of the patent. It is wholly as if we went back to the Patent Office and found a piece of paper with some scribbling on it in the examiner's handwriting.

The Court: This is not a review of the examiner's work, and——

Mr. Harris: Yes, your Honor, it is. I beg your pardon.

The Court: I understand that it is an independent determination of the validity of the patent in which the fact that the patent has issued is prima facie evidence of its validity, and that the prior art, which might have escaped the patent examiner's attention, is accorded kind of a different category in our weighing the evidence than the prior art which he did consider.

Mr. Harris: Yes, your Honor.

The Court: But I have never had his work papers brought in here.

Mr. Lyon: I have been practicing patent law for 20 years, your Honor, and this is the first time anybody has tried to put something like this in evidence in my cases.

The Court: It might be valid, counsel, but it is a point of novelty in this department, at least.

Mr. Harris: I think there is no question of admissibility, your Honor. I think it is clearly [156] admissible under the statutes. It is an official document and a certified copy of an official document. I think the question is the weight to be accorded by the court——

The Court: Even official documents must have relevancy to the case.

Mr. Lyon: That is correct.

Mr. Harris: This has relevancy to the examination made by the Patent Office in considering the

application for the Stauffer patent in suit. This is relevancy.

The Court: Have you seen it, Mr. Lyon?

Mr. Lyon: Yes, I have seen it, your Honor. As I say, it is just the same as if—there is a word here under “Examiner” of “Miles”.

We have no way of knowing what that means. This is just his notation of the work he has done.

The Court: Actually, is this a review of his determination in the way that, say, we review the referees in bankruptcy? There we act rather as an appellate court.

Mr. Lyon: No, your Honor, this is not.

The Court: I have understood that a trial of the validity of a patent is not comparable to a review from any one of the many commissioners or special bodies, finders of fact, whose opinions we do review.

Mr. Harris: Of course, we are not making any contention on that score. We are simply suggesting [157] that this document is relevant to show the field which the examiner searched when he considered this application for the patent in suit. It is a part of the official records of the United States.

It shows he did not consider the field of search in which two of these prior art patents are located.

Mr. Lyon: The file wrapper of the patent in suit is admissible, your Honor, on the ground that it shows the negotiations leading up to the grant.

The Court: It was admitted, wasn't it?

Mr. Lyon: Pardon?

The Court: I have admitted it.

Mr. Lyon: That is right. And he is attempting to supplement the file wrapper by showing what was in the mind of one of the parties, uncommunicated to the other.

The file wrapper comes in because it is communicated, it is acts between the parties. This is a totally unilateral document.

The Court: Kind of a work sheet?

Mr. Lyon: Exactly, it is a work sheet.

Mr. Harris: It is a work sheet. It is part of the records of the United States Government, and I think it is admissible clearly. It is a question of relevancy.

The Court: If it is clearly admissible you will have no trouble finding a case which so holds.

Until such a case is produced, I believe it is [158] inadmissible, although it is certified.

Mr. Harris: Very well, your Honor. May we have it marked for identification?

The Court: Surely. Tell us what number.

The Clerk: Defendants' B-2 for identification.

The Court: Thank you.

(The document referred to was marked Defendants' B-2 for identification.)

Mr. Harris: I might say at this stage I particularly call the court's attention to pages 13 and 24 of the file wrapper of the Stauffer patent in suit.

The page numbers, your Honor, are written in pencil on the bottom of each page. I particularly call your attention to pages 13 and 24.

Page 13 being the original drawing filed by Mr. Stauffer with his original application. Page 24 be-



ing the presentation of the predecessor of Claim 1 of the patent in suit.

In other words, page 24 of the file wrapper shows Claim 1 as it was originally submitted to the Patent Office as Claim 10 of the application. That claim on its face, as so submitted on page 24 of the file wrapper, shows the amendments which the applicant, Mr. Stauffer, made to claim 10 before the Patent Office would allow the claim.

We are suggesting that those amendments are [159] very material to this issue here.

The Court: I made a note of those pages. Do you want me to examine it now in order to better understand other evidence that comes in, or may I—

Mr. Harris: No, your Honor, not now, thank you.

The Court: All right.

Mr. Harris: Next, if the court please, I produce a photoprint copy of page 1286 of the Official Gazette of the issue of September 29, 1931, which I ask be marked as Defendant's Exhibit B-3 for identification.

(The document referred to was marked Defendant's Exhibit B-3 for identification.)

Mr. Harris: I offer this into evidence at this time.

Mr. Lyon: On what theory.

Mr. Harris: This is also a copy of the official publication of the United States Patent Office. It shows an abstract of the Gunderman patent, No.

1,825,588, upon which we are relying here in this case as a defense.

It shows the search classes in which this patent is located in the Patent Office records, which does not appear on the face of the Gunderman patent itself.

The Court: Well, even if the patent examiner in this Stauffer case had found that patent and had determined that it was not an anticipation of this present patent, if this court felt that it were, it wouldn't make any difference, would it? [160]

Mr. Harris: It wouldn't make a bit of difference, that is correct. I am probably going through these two exhibits in excess of caution, so far as the record is concerned.

The Court: It seems to me that caution just hangs onto use with a great deal of force, or a great deal of weight.

Mr. Harris: At any rate, we think the last exhibit, Exhibit B-3 for identification, is clearly admissible and relevant, both. We offer it.

Mr. Lyon: I certainly object to it. I know of no theory on which——

You do intend to offer the Gunderman patent itself, do you not?

Mr. Harris: Oh, certainly. As I say, the search class in which the Gunderman patent is located does not appear on the face of the Gunderman patent.

The Court: It is rejected, that is, this particular exhibit, the Gazette, is rejected without prejudice, and if you have some authority, some court, to the

effect it should be admitted, then I will reconsider the offer.

Mr. Harris: Thank you, your Honor.

Next, if the court please, may I call Mr. Knapp to the stand. [161]

ROBERT T. KNAPP

called as a witness on behalf of the defendant, having been first duly sworn, was examined and testified as follows:

The Clerk: Please take the stand.

Will you state your name, please?

The Witness: Robert T. Knapp.

The Clerk: How do you spell your last name?

The Witness: K-n-a-p-p.

Direct Examination

Q. (By Mr. Harris): What is your residence address, Mr. Knapp?

A. 1801 North Country Lane, Pasadena, California.

Q. Do you have any interest, financial or otherwise, in the outcome of this case? A. I do not.

Q. What is your present occupation?

A. I am professor of hydraulic engineering in the mechanical engineering department in the California Institute of Technology.

Q. How long have you been employed by the California Institute of Technology?

A. Since about 1922.

Q. Will you state briefly and generally some of the courses which you have taught at the University or Institute?

(Testimony of Robert T. Knapp.)

A. I have taught mechanical drawing, mechanism, [162] applied mechanics, strengthen materials, thermodynamics, hydraulic and power plant laboratories and hydrodynamics. I think that is the general ones.

Q. Dr. Knapp, what is your academic background, briefly?

A. I studied for about three and a half years at the California Institute of Technology and then went back to the Massachusetts Institute of Technology for a bachelor's degree in mechanical engineering.

Q. When did you receive that?

A. That was in 1920.

Q. Then what did you do?

A. Then I was asked to return to the California Institute in 1922 as instructor, and during the time I was instructor I also studied for the doctor of philosophy degree in mechanical engineering.

Q. Did you receive such a degree?

A. Yes, received it in 1929.

Q. Dr. Knapp, are you listed in any national directories?

A. Yes, in Who's Who in Engineering, American Men of Science, and the general Who's Who.

Q. By the latter you mean Who's Who in America?

A. Who's Who in America; excuse me.

Q. Are you a member of any national, [163] professional or honorary societies?

A. I am a member of the American Society of

(Testimony of Robert T. Knapp.)

Mechanical Engineers, the American Society of Civil Engineers.

I am a fellow of the American Physical Society. I am a member of the American Geophysical Union, and some of the engineering honorary societies, Alpha Beta Phi and Sigma Psi.

Q. During the last 20 years have you had any practical experience in applied engineering?

A. I had an opportunity to do considerable consulting work on quite a wide variety of subjects with engineering and government firms, government departments.

Q. In general, what practical experience have you had in the design or building of machinery?

A. In some of the consulting work I have had to design and supervise the construction of special equipment.

My main interests have largely been in research in engineering, and as such I have had to design and supervise construction of considerable large scale apparatus and also precision instruments, optical instruments and mechanical instruments.

Q. Have you had any experience or are you familiar with United States Letters Patent?

A. I have taken out a few patents at the request of some of the people I have done consulting work for. And I have had some experience in studying patents of others. [164]

I do have a speaking acquaintance—not a very liberal one—with patent literature.



(Testimony of Robert T. Knapp.)

Q. You say you have taken out patents. What do you mean by that?

A. Well, I mean that I have applied for patents on devices and the patents were granted on machines and on instruments.

Q. Are you a patent attorney, yourself?

A. No.

Q. You haven't acted as a patent attorney for others, have you?      A. No.

Q. Are you familiar with the Stauffer Patent No. 2,240,679 involved in this action?

A. I have read the patent.

Q. Do you have a copy before you?

A. Yes, I think I can find it in here.

I am sorry, but it must be mixed up with some of this other literature. Oh, yes.

Q. Will you kindly describe briefly what this patent relates to and the construction shown in it?

A. The patent drawings are labeled "Muscle Relaxing Machine". The Figure 1, I believe the most of it is shown on the large diagram on the board. Figure 1 shows the couch with a person lying on it for treatment. [165]

Figure 2 is a vertical section of the operating mechanism of the applicator or paddle. This consists of a support projecting upward from a pivot on the base.

Q. Excuse me. What is the support number?

A. The support number is 20. Pivoted—the bearing, I think, labeled 22, which is carried on

(Testimony of Robert T. Knapp.)

what appears to be a piece of chanel iron labeled No. 4, which is fastened to the frame 26.

Mr. Lyon: Excuse me, Doctor. May I inquire, that handwriting on that patent, is that your own handwriting?

The Witness: All the notes on all the patents are in my own handwriting.

Q. (By Mr. Harris): Now, will you please continue your description of Figure 2 of the Stauffer patent in suit?

A. At the top of this arm 20 there is a pad or a table—well, let's say a tablet—fastened to it at what appears to be 90 degrees.

Q. What is that number?

A. That is No. 18. To see the details of the mechanism which oscillate the structure we have to go to Figure 3, because some of it is concealed by Figure 2 by the member being in front of it.

The same numbers, I believe, are carried on Figure 3, with additional ones from the other members. This is oscillated through a rather complicated linkage. [166]

Arm 28 goes from this support member to a pivot point 30 (indicating).

Q. Excuse me, Dr. Knapp.

A. Could I use that drawing (indicating)? I think it is an identical copy?

Q. I think this would be a little more satisfactory in explaining it to the court, to use this enlargement of Figure 1.

The Court: It certainly is easier to follow you

(Testimony of Robert T. Knapp.)

on that one, because you can point. It is kind of difficult to follow on the soft copy.

The Witness: Here we have this support member with a table (indicating).

Now I would like to see how it is fastened on here, and we go down to this member and see that at this point, which is here concealed, we have a pivot point (indicating) and a connecting rod or pitman coming over to this pivot point 3 (indicating).

Q. (By Mr. Harris): What is that connecting rod numbered?

A. That is No. 28, and the pivot point is numbered 30.

Now, this is a junction of three members (indicating), a link 32, which is numbered only up here (indicating),— That is common at the point 30 and comes over to a fixed support, which is here numbered 36 (indicating). [167]

And here 36 seems to go to the base, but it must be this vertical support which carries the other end of the link 32 (indicating).

Also, at the pivot point 30 is connected the projecting link of an eccentric strap, which goes around the eccentric cam—I prefer the word “eccentric”—No. 40.

Q. What is that link numbered in Figure 3, please?

A. The link is not numbered in Figure 3. We have to go back and forth between the two to get all the numbers.

(Testimony of Robert T. Knapp.)

The eccentric strap is numbered 38 in both figures. This eccentric is carried on a shaft numbered 42 on bearings, which are carried on a base. The bearings are numbered No. 44.

This same shaft carries a pulley (indicating), I believe No. 48, which is with a belt connected to the motor No. 50, so that the motor No. 50 drives this shaft No. 42 together with the eccentric (indicating).

The eccentric strap, that is moved by the eccentric or cam, then oscillates point 30, which is constrained to move in a circular path by this little link 32 (indicating).

That then transmits the motion to the link 28, which is nearly at 90 degrees to the motion of the eccentric, and this in turn oscillates the support 20 (indicating).

There is a spring in between some of the parts, of the fixed parts and the arm 20, I presume, to [168] take out slack and keep the bearings tight.

Q. What does the Stauffer patent in suit teach with regard to movement of the upstanding arm or support 20?

A. Well, if I read the specifications of the construction, it teaches that the arm 20 could be constrained to move in an arc, which lies wholly on one side of the vertical.

Q. Is that arc shown in the drawings?

A. Two positions are shown, the solid one and the dotted one, both of which are on one side of the vertical.

(Testimony of Robert T. Knapp.)

The description also teaches that that inclination should be toward the head of the patient.

Q. Dr. Knapp, have you made any study of the type of motion that is imparted by this mechanism of the patent in suit to the support 20?

A. Yes, I made a little analysis of the mechanics of the motion, in order to try to understand some of the other description and claim material found in the patent.

Q. Will you describe the conclusion that you came up with on that?

A. The reason I made the investigation was because I found the statement in the patent that this applicator or paddle had "more effect" when moved in one direction than the other.

And since, obviously, the motion is repetitive, the actual motion must be the same in both directions. [169] So I tried to find out what was meant by "more effect," and I thought possibly it was this rather complicated linkage down here (indicating), so I simply made on the drawing board a rough, very rough sketch, rough determination with compass to determine the relative motion of this arm 20 with respect to time, as compared with the motion of the shaft with respect to time, which we assume is a constant motion.

In doing this it turns out that this motion of the arm 20 is something like the quick return motion on a shaper. In other words, it moves faster in one direction than it does the other.

So that although this deviates only comparatively



(Testimony of Robert T. Knapp.)

small amount from simple harmonic motion, it does give a quicker motion in one direction than the return, and therefore might be what is meant by the patent in saying it had more action in one direction than the other.

Q. In which direction does it give a quicker motion?

A. I have to look at my sketch to be sure of that.

What I did here was to lay out on the drawing to the best I could scale from the patent drawings the points of motion of these three pieces of the linkage.

Then giving them numbers on the 30-degree points clear around the full 360-degree circle, I carried this motion across to the final point—I don't believe it is numbered—on the arm 28, where it connects to the support 20. [170]

The most rapid point of motion seems to be point 5 to 11. It seems to be on the forward point, on the forward half of this motion toward the head and the first half of its return from the head.

In other words, coming over slowly and speeding up and coming back and then going slowly the second half.

Q. What do you call a study of that kind? Is it a time motion study?

A. No, I would say it was a Keno-Matic study of the motion of the parts.

Q. Now, what does the Stauffer patent in suit, so far as the specification is concerned, teach to

(Testimony of Robert T. Knapp.)

you as to the extent of movement of the support 20?

A. In the specifications it defines this rather carefully on the bottom of page 2 in the first column.

Q. Would you please read that portion you refer to?

A. Yes, it begins, I think, about line 72 in the first column, or, 71:

“Operation of the machine causes the member 18 to be oscillated upon its hinge at 21, carrying the member forward and upwardly, due to radius of the arm of movement, for as will be noted from the drawings, the degree of movement ranges from about minus 15 to minus 5 degrees from the vertical, thereby causing the manipulator to swing through a range of 10 degrees, during which [171] interval the seat or manipulator support 20 at no time passes the vertical, hence movement imparted to a body lying thereon is accentuated in that its greatest thrust or lift is in one direction only, the return movement being a lowering and receding movement as distinguished from a positive upward and forward lift.”

Q. What is the subject matter at the top of column 1 on page 2? Does that have any relation to this?

A. This is also a description of the—we have to go to the bottom of page 1 and start this where it discusses this seat 18, which I have been calling an applicator or a paddle.

Q. Would you read the portion you refer to?

(Testimony of Robert T. Knapp.)

A. "A padded structure in the form of a seat 18 is fixedly positioned upon legs 20 which are oscillatably positioned upon bearings 22 secured upon a transversely positioned member 24, which is in turn suitably secured to the frame 26 of the couch 10. The legs 20 as will be noted in the drawings, are inclined toward the head A of the couch, the degree of inclination being relatively small, being of a probable maximum of 15 degrees from the vertical when in extreme forward position and approximately 5 degrees from the vertical when in the other extreme end stroke position. This arrangement causes the seat 18 to lie at a constant [172] although variable angle with respect to the upper surface of the couch."

Q. Dr. Knapp, what does that last phrase mean to you, that phrase which says, "\* \* \* a constant although variable angle \* \* \*"?

A. Well, to me it seems at first sight quite ambiguous, saying "\* \* \* a constant although variable angle \* \* \*"

After looking at the drawings and reading the rest of the specification the only meaning that I can get out of it, that isn't ambiguous, is that the seat 18 here (indicating) shall always lie at some angle to the horizontal, and vary, but never reach the horizontal. That is all I can make out of "\* \* \* a constant although variable angle \* \* \*"

Q. Is there any chance in the patent in suit of that seat or pad 18 ever reaching a horizontal position?           A. No.

(Testimony of Robert T. Knapp.)

Q. As disclosed in the drawings and specifications in the patent in suit, does the support 20 for the seat 18 ever reach or pass beyond the vertical?

A. No, it specifically states in the specifications that it does not.

The Court: Never reaches the vertical?

The Witness: Never reaches the vertical. This was in that part of the text I read in that first section.

Q. (By Mr. Harris): Dr. Knapp, I show you Plaintiff's Exhibit 16, a drawing of one of the defendant's machines. [173]

Are you familiar with the drawing that is before you?

A. I have seen a copy of this same drawing.

Q. Have you made a study of it?

A. Yes, I have examined it.

Q. Now, with a pencil would you kindly put on the drawing — I suggest in Arabic numerals — an Arabic numeral to indicate, or identify each of the views on the drawing and describe very briefly what each view shows. Let's start up here in the upper right hand corner?

A. Let's call this 1?

Q. Let's use Roman numerals.

A. All right.

Q. What does that view generally show?

A. That is a side view, I would say, of the couch and applicator with the covering panels on, as it would appear when in use.

Q. And then would you mark this II, if you

(Testimony of Robert T. Knapp.)

please. A. (Witness complies.)

Q. What does that view generally illustrate?

A. This appears to be the top view of the couch and operating mechanism with the tops and pads removed; probably a section just below the top.

Q. Then will you mark the next III?

A. (Witness complies.) [174]

Q. I think there may be some confusion if you put it there. Perhaps if you put the Roman numerals out at one side it will not be confused with the view below. A. (Witness complies.)

Q. What does the view, the III, show generally?

A. This is a larger scale view of the machine as seen in Figure I, a side view, but with the covering panels removed so that some of the mechanism can be seen.

Q. Then will you kindly mark this view as IV.

A. (Witness complies.)

Q. And that is a section on the Line BB of Figure III, is it?

A. That is shown, the section line is shown in Figure III as the section from—looking towards the foot, I believe.

Q. Then will you kindly mark this view V?

A. (Witness complies.)

Q. And is that view a section of the Line CC, taken on Figure III?

A. Yes, this is also shown on Figure III.

Q. Looking towards which end?



(Testimony of Robert T. Knapp.)

A. The vertical section. Again looking towards the foot.

Q. You have marked the last few, I believe.

A. Started to mark VI. [175]

Q. VI, is that likewise a section but taken in the line DD? A. DD is right.

Q. Shown in Figure III?

A. That is right. Again a vertical cross-section, looking in the same direction as the other two.

Q. Now, will you kindly describe in a little more detail the operating mechanism shown on the right-hand side of Figure III of this drawing applying Arabic numerals to the parts as you point them out to the court.

A. If we start from the top down, I would say—

Q. Start with 10.

A. —10 is a pad which is fastened to the top of a rocker arm, which we can call 11.

This rocker arm is pivoted on a bearing 12, which is carried on a support 13, which is fastened to the tabletop; welded to the tabletop, I would imagine. This appears to be an angle iron fastened to the top (indicating).

Q. Excuse me. In this machine shown in the drawing is there one pad 10 or more than one pad?

A. If we go down to Section CC, Figure V, there are four pads, two on each side.

Q. Are the arms 11 in Figure III shown in this view, Figure V? A. They are. [176]

Q. Would you mark those as 11 on both sides?

(Testimony of Robert T. Knapp.)

A. May I mark one 11-A? They are somewhat different.

Q. Yes, indeed. So that, as I understand your testimony, in the defendant's machine shown in this drawing there are two pads mounted on the arm 11 and two pads mounted on the arm 11-A, is that correct? A. That is correct.

Q. Is there any connection, mechanical connection between the arms 11 and 11-A in this machine shown by this drawing?

A. Arms 11 and 11-A are pivoted on the same pivot which runs in bearing 12. Shall we give that another number?

Q. If you will. A. Pivot shaft here.

Q. Yes. A. I think we are up to 14.

Q. That is a shaft, is it?

A. That is a shaft that goes across the width of the machine between these two supports 13. Two supports 13 are shown in Section CC as well.

Q. And going back, is there any connection between the arms, any mechanical connection between the arms 11 and 11-A that are on that transverse rod?

A. No, they are both free to oscillate about this rod independently. [177]

Mr. Lyon: How do you show that?

The Witness: This line here is a division line from 11 and 11-A (indicating).

Q. (By Mr. Harris): Now, will you please mark that line that you have just pointed to with 15, the division that you referred to?

(Testimony of Robert T. Knapp.)

A. (Witness complies.)

Q. Then going back to Figure III on this drawing, will you continue your explanation of the general construction?

A. Yes. This arm 11 has an intermediate pivot point on it, which we can call 16.

Q. You say a "pivot point". What sort of a point is that?

A. Well, there is a small shaft that runs across—we can see it best on this Section CC. There is a small shaft. We will label this 16, which is shown here,—

Q. Yes.

A. —which is fixed to the arm 11 and goes through one end of a pitman or connecting rod at that point.

Q. Will you mark that connecting rod as 17?

A. (Witness complies.) Connecting rod 17. The other end of this goes over to a similar shaft, to 15, which is located on another set of supports. This shaft I will label 18. This is carried from another set of supports.

Q. Do those supports hang from the top of the table or are they— [178]

A. They hang from the top of the table in the same manner that supports 13 hang; call them supports 19. These carry bearings similar to those shown in 12, through which this rod, this shaft 18 can be rotated.

These are bearings 20 in this view. This is shown partially in Section DD.

(Testimony of Robert T. Knapp.)

Q. And how is the connecting rod or pitman 17 connected to the shaft 18?

A. The connecting rod 17 on the large end of it, it is enlarged to go around the outside of an eccentric which is carried on this shaft 18.

This eccentric—since this is an assembly drawing it is a little difficult to indicate exactly which part is which. I think this is the large end of the connecting rod 17. We will call it 17.

Q. I think we already have a 17. 17 is something up here (indicating).

I beg your pardon. It is the connecting rod.

A. It is the connecting rod, and this is the cam (indicating), which I believe we can call 21.

Q. Yes.

A. This cam, incidentally, is not the same as the cam on the other side of the machine working on 11-A. That is why I wish to have a separate number. [179]

Q. You refer to a cam on the other side of the machine. Where is that?

A. That would be this cam No. 22, which drives the pitman which oscillates the arm 11-A.

Q. So those arms 11 and 11-A are separately driven?

A. They are separately driven by separate pitmen.

Q. And what is the drive connection?

Mr. Lyon: What is the number of this cam?

The Witness: This cam I have called No.—

Mr. Harris: 21.

(Testimony of Robert T. Knapp.)

The Witness: —17.

Mr. Harris: Excuse me.

The Witness: 21.

Q. (By Mr. Harris): The connecting rod is 17 and the cam is 21 and the second cam is 22.

Mr. Lyon: And the shaft is 18?

Mr. Harris: The shaft is 18.

The Witness: The shaft is 18. Now, it is impossible for me to tell in this drawing which part corresponds to which in the functioning of this assembly 22.

Now, the eccentric or cam 21 is a simple eccentric fastened to the shaft 18. The eccentric 22 is made of two pieces. One, a sleeve with a dog clutch, which is fixed by set screws to the shaft. This I think is what I have labeled 22. [180]

Mr. Lyon: May I have that read?

(The record was read.)

The Witness: I will revise this, to call this 22-A (indicating). The eccentric itself is loosely carried on the eccentric carrier 22-A. The eccentric itself is 22-B. It also has the engaging member, the opposite engaging member of this little dog clutch.

Q. (By Mr. Harris): What is the purpose of that little clutch in there?

A. The clutch permits a free sliding of 180 degrees of the eccentric on the shaft, so if the shaft is revolved in one direction the eccentric slips until the dog clutch comes along and drives it then continuously at that phase angle with respect to the eccentric 21.



(Testimony of Robert T. Knapp.)

If the motor is reversed, then the dog clutch permits the eccentric to slide 180 degrees out of phase and changes the action of the eccentric and the pitman and the oscillating arm.

Q. How is that shaft 18 driven?

A. Shaft 18 is driven—we can see this in view III—is driven by a simple pulley on its outer end, and the end towards this end of the view (indicating) by a small electric motor fastened to the lower part of the base.

This motor is the reversible motor which I was saying made this possible to revolve this in either direction. [181]

Q. Dr. Knapp, have you ever seen any actual machine built as generally shown in this drawing before you?

A. I have seen the *Slenderella* table.

Q. Now, would you describe briefly to the court just what effect or how this operates? Do these pads which you have marked 10 on Figure III, do all these pads operate together in the operation of this machine, or what is the operation?

A. The operation of this machine is a program operation with a timer which controls the motion of the three possible events that can occur, plus rest periods.

The mechanism which we haven't described on the left hand side of the table is a simple linkage which makes it possible to oscillate the whole table a small amount.

(Testimony of Robert T. Knapp.)

Q. By "the whole table" do you mean the whole couch?

A. No, the couch top which is pivoted on two arms. Do you want me to mark these?

Q. Yes, I think you should.

A. I wish someone would keep track of these numbers. 23, I believe, is the next.

Q. Let's mark it 24 and be safe.

A. Let's call this one 24 and a similar one over here 25 (indicating). Arm 24, in addition, carries a little offset arm, which is driven by another pitman from a shaft and a separate motor. [182]

When this motor operates it causes the whole table top to oscillate back and forth longitudinally.

Q. Does that have any effect on the operation of the pad 10?

A. No, the pad 10, the mechanism for the pads 10, with the exception of the motor itself, are carried on the top of the table so that when this is operated it does not make this move (indicating).

Q. So, as I understand you, there is one type or one setting of operation for this particular machine, which you just described, and in which the tabletop moves as a whole back and forth?

A. That is right. The three possible motions then are with the tabletop oscillator motor operating, and that would be the same in no matter what direction that motor operated.

And then the two possible motions when the applicator or paddle oscillator motor is operated first in one direction and then the other.

(Testimony of Robert T. Knapp.)

Q. Will you explain that?

A. This is the program. The program seems to be that first, when the machine starts to operate, the motor operates in such a direction that the two arms 11 and 11-A operate together in unison, like this (indicating).

Q. Does that make the paddles on the arm move in unison? [183]

A. The paddles on top move in unison, so that there is a simple back and forth motion.

Mr. Lyon: At that time is what you call the dog clutch firmly engaged?

The Witness: Yes, the clutch is simply a limit which will permit a motion of 180 degrees, a half a revolution in one direction or the other. All during each operation it is engaged on one phase of the clutch.

Q. (By Mr. Harris): Would you explain the next position of operation?

A. Then the machine pauses for a short time and then goes to the reverse. See, this motor is reversed.

Q. There is a reversible motor used in this machine?

A. Yes. When the motor reverses arm 11 does exactly what it did before, but the eccentric which drives arm 11-A slips this 180 degrees and then it is firmly driven from then on.

And the motion of these two arms or the two pads are like this (indicating), they are just exactly opposite in phase.

(Testimony of Robert T. Knapp.)

Q. They move in opposition?

A. They move in opposition, yes.

Q. Next I place before you Plaintiff's Exhibit 17, which is the drawing of the defendant's Sacro-Matic table.

Would you briefly describe whether this shows [184] substantially the same mechanism as the other drawing, Exhibit 16, and any major differences in the two mechanisms.

A. Substantially the two machines operate in the same manner. The construction differs in a few minor points.

In this machine most of the construction is by welding. In the other machine it was partially welding and partially casting.

In this machine the drive motor for the applicator or paddle is carried on a bracket which comes from the tabletop instead of from the lower part of the couch.

Q. Will you mark that bracket with 30, if you please?

A. This bracket, which should also include this piece, is 30 (indicating).

Q. So that in this machine, illustrated by Plaintiff's Exhibit 17, the motor is mounted on a bracket suspended from the top of the table.

Whereas, in the other machine, illustrated by Plaintiff's Exhibit 16, the motor is simply mounted on a separate base. A. That is correct.

Q. Is there any other significant difference that you think of?

(Testimony of Robert T. Knapp.)

A. There are not other significant differences, except in the type of construction. The length of the, or the distance from the lower pivot point to the connection of the pitman is somewhat shorter [185] in this machine than the other, which makes the angle or the amount of oscillation slightly smaller in this machine (indicating).

Q. The arc of movement of the vertical arm in this machine, that supports the pad or applicator, is smaller or greater than in the other machine that is illustrated by Exhibit 16?

A. It is smaller than Exhibit 16.

Q. And does this machine, the Sacro-Matic machine illustrated in Exhibit 17, does that like the other machine have two supports that carry pads or paddles on their tops?

A. Yes, it has two supports. It has two supports that carry paddles on their tops.

These supports are oscillated independently as with the other ones, from two separate pitmen and two separate cams.

Q. Are those supports illustrated in the Sections CC and DD on Exhibit 17?

A. Yes, they are. This also shows the difference in construction, in that these supports are made up of two bars of iron welded to a sleeve at the top—at the bottom, and a pad at the top, in place of the single casting 11 shown before. So we have four, what appear to be four vertical supports in this machine; two for each pad. But they are taking the place of a larger casting.



(Testimony of Robert T. Knapp.)

Q. In other words, the support shown in the Section CC on Exhibit 17 is the same in function as the support 11—— A. Yes. [186]

Q. ——on Exhibit 16, is that correct?

A. Could I use the same numbers on this drawing?

Q. Yes, if you will please.

A. Then this is bracket 11 (indicating), and this is bracket 11-A (indicating). And they differ only in the same features that they differed in this one, in that this carries the dog clutch on the other shaft (indicating).

Mr. Lyon: Where is that dog clutch shown?

The Witness: That dog clutch is shown here in this view (indicating). This is the dog clutch (indicating).

Now, it is a very simple construction, easily overlooked. It is also shown here (indicating).

Q. (By Mr. Harris): By "here" you mean in Section DD?

A. In Section DD it is designated on the drawing as subassembly J, "S.A.J." This is a shop erection drawing.

Q. You said that the support 11 on Exhibit 17 was welded to a sleeve. You also said that the support 11-A on the same drawing was also welded to a sleeve.

Are those two sleeves one and the same or are they separate?

A. No, they are separate sleeves, just as they were in the other type of machine. And the junc-

(Testimony of Robert T. Knapp.)

tion is shown again on the end elevation, which I will label with the same number, 15. [187]

Q. And what is the operation of this machine, the Sacro-Matic machine, shown by Exhibit 17, as compared with the other machine shown in Exhibit 16?

A. As far as I could determine from watching them both operate, the operation, external operation is identical.

Q. They go through the same cycle?

A. They go through the same cycle. I didn't check the time, whether or not they are the same. They appeared to be the same, without taking a stop watch to it; the same sequence, same approximate time.

Mr. Harris: Next, if the court please, I produce a further drawing entitled "Slenderella Tables Operating Mechanism Range of Movement" which I ask be marked as Defendant's Exhibit C.

The Clerk: Defendant's Exhibit C for identification.

(The document referred to was marked Defendant's Exhibit C for identification.)

Q. (By Mr. Harris): Dr. Knapp, I show you Defendant's Exhibit C for identification. What is that drawing?

A. This is a drawing of the supports, the pad supports, the pitman and the eccentric of these two types of machines we have just been discussing.

Q. And under the left-hand view I notice the

(Testimony of Robert T. Knapp.)

legend "Drawing 9-26-56". Does that refer to the mechanism illustrated in—— [188]

A. I think this drawing, which was——

Q. Exhibit 16?           A. ——Exhibit 16.

Q. And then under the right-hand view on Defendant's Exhibit C there is the legend "Drawing 6-5-56", and does that refer to the mechanism illustrated in more detail in Plaintiff's Exhibit 17?

A. Yes. This is the corresponding arm and support, and so forth.

Q. I note that the parts in this drawing, Exhibit C, are much larger than illustrated in the other drawings, Plaintiff's Exhibits 16 and 17. What is the explanation for that?

A. This appears to be a full size drawing of the two. This is the casting which we referred to on the first machine and this is the welded replacing structure on the other one (indicating).

Q. Well, now, using this drawing, Defendant's Exhibit C, will you kindly explain the range of movement of the upwardly directed supports in each of the views on this drawing?

A. Both of them are driven by the two pitmen which are caused to move back and forth by the eccentrics.

The support is pivoted around this shaft labeled "pivot" and is moved back and forth by this pitman under the influence of the eccentric (indicating). [189]

The three positions shown are the center position and the two limits.

(Testimony of Robert T. Knapp.)

Q. By the three positions you are referring to the full line position? A. Full line position.

Q. The full line position. And then there is a heavy dashed line position and a light dashed line position in each of the views?

A. That is correct.

Q. Are those the three positions you are referring to?

A. Yes, the full line position is the center position. The heavy dashed line is the position at the end of the motion towards the head of the table, and the light dashed line towards the foot.

Q. You have examined the Slenderella tables corresponding to the structures shown in Plaintiff's Exhibits 16 and 17, have you? A. I have.

Q. And how do these views, illustrated in Defendant's Exhibit C, correspond with the actual motion of the corresponding parts in the actual tables which you have examined?

A. If these are supposed to be full size drawings—and they appear to be—I would say that in both cases the actual arc of motion is greater than is used on the tables.

Q. In other words, in the tables you have [190] actually examined they have a smaller arc of movement than is shown by this Exhibit C, is that correct?

A. That is correct. I have measured both of them. I have the figures in my notes.

Q. Yes. Will you please tell us just what those

(Testimony of Robert T. Knapp.)

notes show with respect to that motion in the tables that you have examined?

A. I seem to have too many envelopes.

The Court: Well, it might be a good time to take our afternoon recess.

Mr. Harris: Very well, your Honor.

(Whereupon, a recess was taken from 2:46 p.m. to 3:09 p.m.) [191]

Q. (By Mr. Harris): Dr. Knapp, referring back to the defendant's tables illustrated by Plaintiff's Exhibits 16 and 17, do the applicators in those tables move axially of the length of the tables or couches?

Mr. Lyon: Excuse me. Before you go into that, Mr. Harris, I was a little interested in what the witness was testifying about just before we took the recess, about the arc in the tables being less than in the drawing.

Mr. Harris: We will take that up, if the court pleases, later.

The Court: I came back expecting to find that the doctor had located his notes and was going to tell us about it.

Mr. Harris: He has, your Honor. I am afraid I will forget this question if I don't ask him now.

The Court: You do it in your own way. I was just hoping we weren't going to be left in suspense much longer.

Mr. Harris: No, we are not.

The Witness: The pads, as I understand, actually do not move axially of the table.



(Testimony of Robert T. Knapp.)

Q. (By Mr. Harris): What does "axially" mean to you?

A. Axially to me means along the center line of the table.

Q. In the Stauffer patent in suit does the pad move along the center line of the table? [192]

A. From the description in the patent, it does.

Q. Coming back to this question as to the amplitude of movement of the upwardly upstanding support for the pads in defendant's tables exemplified by Plaintiff's Exhibits 16 and 17, which tables you have actually seen, will you please describe the amplitude of movement in each of those two tables?

A. On the table which we first discussed, Exhibit 16, I measured the horizontal amplitude of the applicator which is pad C—or, pad 10, and found that the total movement from one side to the other was 7/8ths of an inch.

Q. What was the total movement in the other defendant's table?

A. On the other table, drawing 17——

Q. Exhibit 17?

A. ——Exhibit 17, called the Sacro-Matic table, the motion was somewhat less. It was, as I measured it, about 49/64ths. It compares to 7/8ths as 56/64ths; 49 to 56.

Mr. Lyon: This measurement, did you make it from these drawings?

The Witness: I made it from the machines.

Q. (By Mr. Harris): Now, did you measure the amplitude of the arc of movement in degrees—

(Testimony of Robert T. Knapp.)

the amplitude of the arc of movement of the [193] upstanding supports for the pads in both of the defendant's tables?

A. I measured it in only the Sacro-Matic tables, but on that I measured the arcs on six tables.

Q. Will you please give the results of those measurements?

A. Yes. These six tables were all that were in the particular salon that I had access to.

Perhaps I had better, before I say what the angle was, tell you how I measured it.

Q. Yes, if you will, please.

A. I brought my so-called combination square. The protractor head which contains a movable protractor and the level bubble, because the discussion seems to be concerned with angles with respect to the horizontal and vertical, and the level bubble is an independent reference.

With this I was able to place this on the vertical arm and then adjust the level bubble until it showed a level, and then take off and read the arc. The accuracy, I would say, was about a quarter of a degree.

I found that—I think I had better read what I found and also describe what I mean. I measured the angle with the horizontal first, as the pad was in its furthest excursion towards the foot of the table, and then measured it at its furthest excursion towards the head of the table.

On the first unit which I measured these angles [194] were both one and a half degrees with the

(Testimony of Robert T. Knapp.)

vertical. One on one side of the vertical and the other on the other.

On the next table it was one degree towards the foot, two and a quarter degrees towards the head.

On the third table it was two and a quarter degrees towards the foot and one degree toward the head.

On the fourth table I measured what appeared to be slightly less than one and three-quarters degrees towards the foot and one and three-quarters degrees toward the head.

On the fifth table two degrees toward the foot and one and a quarter degrees toward the head.

On the last table, the sixth table, two and three-quarters degrees towards the foot and one-half degree towards the head.

I checked the over-all excursion by measuring this amplitude and the radius of the vertical arm and calculated the angle. It came out about three and a half degrees, which is within the limits of accuracy I would expect from my measurements.

Q. Have you made any measurement of the speed of reciprocation of the pads in either of the defendant's accused machines?

A. I counted the number of oscillations against a sweep second hand for a minute on the table shown in Exhibit 17, and that, as I counted, was 186 oscillations per minute. [195]

Mr. Lyon: How many was that?

The Witness: 186, plus or minus a couple.

(Testimony of Robert T. Knapp.)

Q. (By Mr. Harris): Did you observe the operation of any of the Sacro-Matic machines?

A. Yes. I did not watch them through a time cycle, but I operated them by turning them to one of—to each one of the three possible movements.

Q. And how did the rate of movement of the pads in the Sacro-Matic machine compare with the rate of movement of the pads in the machine shown in Exhibit 16?

A. As near as I could see, they were the same. I felt the same rhythm. I also noted that the pulley sizes and the motor speeds seemed to be the same in the two machines.

Q. Referring to the mechanism shown in the drawings of and described in the specification of the Stauffer patent in suit, and with particular reference to the motion relationship study that you made, what type of motion does the support 20 have in the patent in suit?

A. In the Stauffer patent?

Q. Yes. Is there any way to describe it generally?

The Court: Where is 20?

The Witness: The vertical arm.

The Court: I see it. I just couldn't find it.

Q. (By Mr. Harris): May I put it this way: [196] Does that mechanism in the Stauffer patent in suit operate in simple harmonic motion?

A. No, it does not. It operates one-half of the cycle taking place faster than the other half.

Q. And how about the defendant's accused ta-

(Testimony of Robert T. Knapp.)

bles shown by Exhibits 16 and 17 that you have seen, what type of motion do the pads have in those tables?

A. They approximate very closely simple harmonic motion.

The Court: Can you define simple harmonic motion for me?

The Witness: Simple harmonic motion is a motion which you obtain if you have a crank and connecting rod going to a piston, such as the motion of a piston in an internal combustion engine, automobile engine, and so forth, where the crank moves at a constant speed and the piston starts from one end of its stroke, slowly accelerating to maximum at the center and decelerating at the end, and repeating this very nearly on the return stroke.

It is defined by the relationship with the sine of the angle. You can express it mathematically, exactly, a pure simple harmonic motion.

Q. (By Mr. Harris): The word sine, s-i-n-e——

A. S-i-n-e.

Q. ——is a mere mathematical term, is it not?

A. It is a mathematical term which defines the [197] ratio of two sides of a triangle.

Mr. Harris: Does your Honor have any further questions?

The Court: No.

The Witness: I can draw what I mean on the board.

Q. (By Mr. Harris): I don't think it is required.



(Testimony of Robert T. Knapp.)

The Court: No. I think I follow it.

Mr. Harris: Next, if the court please, I produce a booklet containing, first, United States patent to Parker, No. 1,978,223, and United States patent to Miller, No. 1,953,424, and United States patent to Gunderman, No. 1,825,588.

I ask the booklet be marked as Defendant's Exhibit D, and that each of the three patents which I have identified in the booklet be marked separately as Defendant's Exhibits D-1, D-2 and D-3.

(The documents referred to were marked Defendant's Exhibits D, D-1, D-2 and D-3 for identification.)

Mr. Lyon: May we identify which one is which and——

Mr. Harris: Yes, I shall. Parker is D-1, Miller is D-2 and Gunderman is D-3.

I also have here an extra copy of this booklet for the court's use in case the court wishes to mark the copies up in any way.

The Court: Thank you.

Q. (By Mr. Harris): Dr. Knapp, do you have before you [198] a copy of the Gunderman patent?

A. Yes, I have such a copy.

Q. Have you studied it and are you familiar with its contents?

A. Yes, I have read the patent. I am familiar in general with its contents.

Mr. Harris: I next produce an enlargement of the Gunderman—I should say an enlargement of sheet 4 of the drawings of the Gunderman patent,

(Testimony of Robert T. Knapp.)

No. 1,825,588, which I ask be marked for identification as Defendant's Exhibit E.

(The document referred to was marked Defendant's Exhibit E for identification.)

The Court: Is that the same as Figure 6? It is an enlargement of 6?

Mr. Harris: Figure 6, yes, your Honor.

Q. Now, referring to the Gunderman patent, Mr. Knapp, will you kindly briefly describe what this shows and relates to?

A. The Gunderman patent is called a portable vibrating machine. This is the working mechanism of it (indicating).

Q. Excuse me just a minute, and I shall get these exhibits out of your way.

A. This machine really has two parts, a left-hand [199] mechanism and a right-hand mechanism.

The right-hand mechanism is a motor or some sort of a drive mechanism which operates two cranks or eccentrics.

Q. The motor is numbered what on the drawing?

A. Motor No. 10.

Q. Where are those cranks or eccentrics?

A. The crank going to the right is No. 21, and that to the left is numbered 50. 21 is carried on a pin which gives it a crankshaft action, which is the same as the eccentric and transmits this motion to the link 17, which is pivoted at the top at point 19 on a bracket 12, which is fastened to the base.

This arm 17 then is oscillated back and forth by

(Testimony of Robert T. Knapp.)

the revolution of the motor and carries a series of hooks 25, which are apparently used for some sort of belt or other mechanism to oscillate the patient's body.

The left-hand side we have an applicator 26 which is pivoted—it is carried on a vertical arm, pivoted on a bearing held at the base. The bearing bracket 41 and the shaft 40 is the pivot around which this oscillates.

Q. What is the vertical arm, how is that numbered?

A. The vertical arm seems to have two numbers, 27 and 31. I think 27 is a rib on the main arm 31.

This is driven by the eccentric 52 through the pitman or connecting rod 50 to the pivot 44 on this applicator 31. [200]

It causes the applicator to move on an arc around pivot point 40.

Q. What is the motion of the vertical arm or support 31 in that movement?

A. As far as it can be determined from the drawing it is approximately simple harmonic motion. In other words, it is a simple crank connecting rod. There is some complication, the fact this is at an angle. This only changes the motion in minor detail.

Q. Is the enlargement, Exhibit E for identification, a correct enlargement of the drawing, the accompanying drawing or the corresponding drawing of the Gunderman patent?

A. As far as I can see it is a direct enlargement

(Testimony of Robert T. Knapp.)

of the drawing, with the exception of these little lucite buttons which are fastened to it.

Mr. Harris: I produce a plastic model which I ask be marked for identification as Defendant's Exhibit F.

(The object referred to was marked Defendant's Exhibit F for identification.)

Q. (By Mr. Harris): Dr. Knapp, I hand you Defendant's Exhibit F for identification. What is that?

A. It appears to be a Keno-Matic model of the machine shown in this patent drawing.

Q. By "this patent drawing" you mean the enlargement—— [201]

A. That Figure No. 6 of the Gunderman patent.

Q. How do the parts of this model correspond with the parts illustrated in the enlargement, Defendant's E?

A. It appears to be the same size and same location. It looks as if we might fit the device to it.

Q. If we could lay this flat on your table here, then will you kindly fit the lucite model, Exhibit F, to the enlargement, Exhibit E, and demonstrate to the court.

What are those lucite buttons for that are on the enlargement?

A. They seem to be orienting buttons, to make this lucite model coincide in position quite closely to that in the drawing.

Q. Will you please operate the lucite model, and as you do so for the record describe what you are

(Testimony of Robert T. Knapp.)

the revolution of the motor and carries a series of hooks 25, which are apparently used for some sort of belt or other mechanism to oscillate the patient's body.

The left-hand side we have an applicator 26 which is pivoted—it is carried on a vertical arm, pivoted on a bearing held at the base. The bearing bracket 41 and the shaft 40 is the pivot around which this oscillates.

Q. What is the vertical arm, how is that numbered?

A. The vertical arm seems to have two numbers, 27 and 31. I think 27 is a rib on the main arm 31.

This is driven by the eccentric 52 through the pitman or connecting rod 50 to the pivot 44 on this applicator 31. [200]

It causes the applicator to move on an arc around pivot point 40.

Q. What is the motion of the vertical arm or support 31 in that movement?

A. As far as it can be determined from the drawing it is approximately simple harmonic motion. In other words, it is a simple crank connecting rod. There is some complication, the fact this is at an angle. This only changes the motion in minor detail.

Q. Is the enlargement, Exhibit E for identification, a correct enlargement of the drawing, the accompanying drawing or the corresponding drawing of the Gunderman patent?

A. As far as I can see it is a direct enlargement



(Testimony of Robert T. Knapp.)

of the drawing, with the exception of these little lucite buttons which are fastened to it.

Mr. Harris: I produce a plastic model which I ask be marked for identification as Defendant's Exhibit F.

(The object referred to was marked Defendant's Exhibit F for identification.)

Q. (By Mr. Harris): Dr. Knapp, I hand you Defendant's Exhibit F for identification. What is that?

A. It appears to be a Keno-Matic model of the machine shown in this patent drawing.

Q. By "this patent drawing" you mean the enlargement— [201]

A. That Figure No. 6 of the Gunderman patent.

Q. How do the parts of this model correspond with the parts illustrated in the enlargement, Defendant's E?

A. It appears to be the same size and same location. It looks as if we might fit the device to it.

Q. If we could lay this flat on your table here, then will you kindly fit the lucite model, Exhibit F, to the enlargement, Exhibit E, and demonstrate to the court.

What are those lucite buttons for that are on the enlargement?

A. They seem to be orienting buttons, to make this lucite model coincide in position quite closely to that in the drawing.

Q. Will you please operate the lucite model, and as you do so for the record describe what you are

(Testimony of Robert T. Knapp.)

doing so that both the court will know and the record will be clear as to just what you are doing in demonstrating the model.

A. Well, I am turning the disk on the shaft corresponding to the drive motor and causing the different parts of the machine to follow the motion they would in the case of the machine itself.

As I turn it, if we look at the left-hand mechanism it will be seen that it oscillates about this point 40 through an arc and back, and oscillates on the other side and [202] back.

Mr. Lyon: May I ask a question?

Mr. Harris: Why, certainly.

Mr. Lyon: As you operate that, Doctor, I notice that the top of applicator 26 as it moves appears to move about an arc which coincides with the top of the applicator 26.

In other words, as you move the model the top of the applicator 26 follows along the top line drawn on the drawing, is that correct?

The Witness: It appears to do so.

Mr. Lyon: There is no lifting effect there, is there? That wouldn't have any tendency to lift anything that was supporting it, would it?

Mr. Harris: Excuse me, if the court please. I think that is cross examination. I welcome any clarification that Mr. Lyon has, but I think that goes in the cross examination.

The Court: Do you object to his doing it now?

Mr. Harris: Yes, I do.

The Court: All right. Sustained.

(Testimony of Robert T. Knapp.)

Q. (By Mr. Harris): What type of motion is this that is exemplified by the model, Exhibit F, with respect to the Gunderman patent and the movement of the support 31 and its applicator 26? What type of motion is that?

A. The motion of this point is the close approximation [203] of simple harmonic motion. And this oscillation has the characteristics of simple harmonic motion.

Q. How does that compare with the motions of the pads in the defendant's machines illustrated by Plaintiff's Exhibits 16 and 17?

A. In general it is very similar. This angle is a greater angle with respect to the horizontal than in either of defendant's machines.

In one this angle is practically—this arm is practically horizontal and the other, it has a slight angle; quantitatively the thing is the same.

Q. By "this angle" you are referring to the angle the arm 50 makes with the horizontal?

A. Yes.

The Court: I thought you had shifted from non-infringement to a lack of invention.

Mr. Harris: We are, we are on that now.

The Court: You seem to be getting back again to the other.

Mr. Harris: We are on both. Things are interchangeable. I mean, they both go together hand in hand. Our point is if the defendant's structure is just like the prior art we can't possibly infringe.

(Testimony of Robert T. Knapp.)

Q. Is there any couch shown or described in the Gunderman patent, Doctor? [204]

A. There is no couch shown here. I will have to refresh my memory, but I believe there is no couch shown in the Gunderman patent.

The Court: I think Gunderman suggests the floor.

Q. (By Mr. Harris): Excuse me. Did you have an answer to that question?

A. No, I find no sign of a couch.

Q. In the Gunderman patent is there only one applicator 26 or are there more than one applicator?

A. On drawing Figure 5, sheet 3, it shows what appears to be a vertical plan, a plan looking down vertically from the top of the machine with two applicators 26.

Q. And as described in the Gunderman patent, do those applicators oscillate together?

A. I believe they are made so they can be, they oscillate—they could be easily set so they oscillate either together or at any phase angle desired.

Q. Are those applicators separately supported on separate supports, or are they supported from the same support?

A. No, they are completely separate. They are separately supported from separate supports, as shown in Figure 5, and seemingly driven by separate pitmen.

Q. How do those compare with the supports and

(Testimony of Robert T. Knapp.)

applicators in the defendant's machines, the Slenderella [205] machines?

A. To me they appear very similar. These are somewhat simpler construction, but very similar.

Q. Dr. Knapp, I note in Figure 6 of the Gunderman patent the connecting rod 50 is connected to the cam or eccentric 51 which is directly connected to the drive shaft of the motor.

Whereas, in the Stauffer patent in suit the drive shaft of the motor and the connecting rod 28, between them is a large pulley 50.

I shall put before you the enlargement of the Stauffer patent drawing. I am pointing out there is a direct drive from the motor through a cam or eccentric and a connecting rod to the vertical support 31 in the Gunderman patent. Whereas, in Stauffer there is an intermediate large pulley 48, which is built connected to the motor and then, in turn, drives a cam shaft or eccentric shaft which is 42 in the Stauffer patent.

What difference, if any, would that make in the operation of these devices?

A. Well, it would make no difference in the general type of motion. It would indicate that probably in the Gunderman machine it would operate at a higher speed because if this is a simple motor it would normally go at higher speed because of the speed reduction shown in the Stauffer [206] patent.

Q. The speed reduction by virtue of those pulleys shown in the Stauffer patent?

A. The pulleys and the belt.



(Testimony of Robert T. Knapp.)

Q. And is it conventional practice or is it not conventional practice in electric motors to include a gear reduction unit directly in the motor itself?

A. This has been a type of motor which has been available for, I would say, approximately 30 years, and which you can buy off the shelf, a motor with an integral gear reduction on one or both ends with specified speeds.

Q. Is there any disclosure in the Gunderman patent as to whether it has such a gear reduction unit or not?

A. I remember no discussion of speed in the Gunderman patent.

Q. Referring next to the Miller patent, No. 1,953,424, which is marked as Defendant's Exhibit D-2, do you have a copy of that Miller patent before you, Dr. Knapp?           A. Yes, I do.

Q. Have you studied it and are you familiar with its contents?

A. Again, I have read it and I am in general familiar with the contents.

Mr. Harris: Excuse me. Before we proceed with that, I offer into evidence the enlargement of sheet 4 of the [207] drawings of Gunderman as Defendant's Exhibit E.

The Court: Received.

(The document heretofore marked Defendant's Exhibit E was received in evidence.)

Mr. Harris: And next at this time, I offer into evidence the lucite model of the Gunderman mecha-

(Testimony of Robert T. Knapp.)

nism, Exhibit F for identification, as Defendant's Exhibit of the same letter.

The Court: Received.

(The object heretofore marked Defendant's Exhibit F was received in evidence.)

Q. (By Mr. Harris): Will you please describe briefly and generally what this Miller patent shows and relates to, first, with reference to Figures 1 and 2 of the drawings in the patent?

A. This shows a machine of the type that we have been discussing here, in which a patient is placed on some sort of a table or in some sort of a chair, if it is like the last one, a portable machine.

This seems to be a semi-portable machine of a relatively low couch, with a head rest and a foot rest that can be placed on the floor, with some sort of an applicator coming up along the axis of the machine. This applicator is No. 27. And some straps going over the body with some sort of devices on the side. [208]

Mr. Harris: Next, if the court please, I produce what purports to be an enlargement of sheet 3 of the Miller patent, No. 1,953,424, which I ask be marked for identification as Defendant's Exhibit G.

(The document referred to was marked Defendant's Exhibit G for identification.)

Q. (By Mr. Harris): Now, with respect to Exhibit G, Dr. Knapp—

Mr. Lyon: Pardon me, Mr. Harris.

Mr. Harris: Yes.

Mr. Lyon: Did you say sheet 3 or is it Figure 3?

(Testimony of Robert T. Knapp.)

Mr. Harris: It is sheet 3. It is Figures 4, 5 and 6. Sheet 3 showing Figures 4, 5 and 6 of the Miller patent.

Q. With respect to this enlargement, Dr. Knapp, is this also a correct enlargement of the corresponding sheet of the Miller patent?

A. I have examined it, and as far as I can see, with the exception of these little buttons again, it is a correct enlargement.

Q. Now, with respect to Figure 4 of the Miller patent, would you kindly describe briefly to the court the mechanical construction of this device, first?

A. The device shown here seems to be a section of the table which we were just examining a minute ago, in which 20 is the top surface and the pad indicated by 22, [209] bolted or fastened to the upper—the supporting surface of this pad is the mechanism, consisting of a motor 49, some sort of a clutch 51, and the reduction gear—it appears to be a worm reduction gear—labeled 50, which carries on the slow speed shaft a crank arm 68, and something similar on the other side in an assembly labeled 53.

The crank arm has a ball and socket joint on it, which is engaged in a connecting rod or pitman 71, driving, oscillating by connection at point 70 a bell crank, which I take it is No. 38, which is pivoted on a shaft, a fixed shaft at 43, and carries on its out-board end a pin 37.

Q. How is that pivot 43 mounted?

(Testimony of Robert T. Knapp.)

A. That is mounted to a bracket which is carried by the frame of the machine.

Q. Suspended from the top of the table?

A. Suspended from the top of the table. Everything is suspended from the top of the table of this machine.

Q. Will you proceed with the explanation of the mechanism? You got to the pin 37.

A. Yes. Now, there is an independent link or lever 35, which is independently pivoted around a shaft, a fixed shaft 41, which is carried by the fixed bracket 40.

On the top edge of this link is a device for holding a movable applicator, which I think is No. 37. This is [210] adjustable about point 32.

Q. Excuse me. Did you refer to the applicator—as what? A. 27.

Q. 27. Yes.

A. This is adjustable—how it sets with regard to the horizontal about point 32, and the whole device can be slid along what appears to be rails 34.

Q. Are those shown in Figure 5 here, that mounting of the applicator—

A. Yes, that mounting is shown clearly in Figure 5 in which 33 is these rails at 34—I see no particular difference between 33 and 34, except the two opposite sides of a T rail is clamped by the bracket 31 coming down from the applicator 27.

Q. Is that whole applicator mechanism adapted to be slid back and forth on the arm or link 35?

A. It can be slid back and forth on the arm or

(Testimony of Robert T. Knapp.)

link 35 and independently adjusted as to tilt around point 32. Then this is an independent link (indicating).

This bell crank is the device which is oscillated by this gear reduction and the bell crank—and the crank on the motor shaft (indicating).

They are held together or caused to move—this link 35 is caused to move by an adjustable link 45, or, 44, [211] which is so fashioned it is a fork and slips over the pin 37 on the outboard end of this bell crank (indicating).

The other end is a yolk carrying—like two fingers of your hand, carrying a pin across it in the horizontal direction, I take it, is 45. That can be dropped into the circular slots 36 that were cut in the bottom edge of this arm or link 35.

Q. What is the purpose of those notches 36 in the arm 35 and the notches 46 in the member 44?

A. Apparently, these notches 46 are to adjust the vertical position, or the angular position of this member 35 with respect to the link 38 and with respect to the machine itself.

In other words, by changing this you change the center of the motion about which this arm will move if this link is oscillated.

If notches 36 appear to be for the purpose of varying the amplitude of this motion, because this has, this pin point 37 has a constant amplitude. Therefore, by moving this towards the pivot point here (indicating), the amplitude of this will be increased.



(Testimony of Robert T. Knapp.)

By moving it away the amplitude will be decreased with a constant motion at this point (indicating). So we have a double adjustment on this.

It also will give a slightly different character to [212] motion. This is a little too complicated and too many sharp angles to say it is approaching simple harmonics. I do not know how far it deviates from it.

Mr. Harris: Next, if the court please, I produce a further lucite model which I ask be marked as Defendant's Exhibit H for identification.

(The object referred to was marked Defendant's Exhibit H for identification.)

Mr. Harris: I display this to counsel.

Q. Mr. Knapp, you have examined this model, have you?      A. Yes, I have.

Q. And what does it represent?

A. It appears to represent the principal operating parts of the drawing as shown here (indicating).

Q. By "the drawing shown here" you mean Exhibit G?      A. Exhibit G, yes.

Q. Will you please superimpose the lucite model on the drawing, Exhibit G, enlargement, and demonstrate to the court, explaining as you do so, the operation of this model and the Miller machine.

First, I suggest, Dr. Knapp, that you arrange the model so that its parts correspond with the position shown on the enlargement, Exhibit G, so that the parts overlay the similar parts on the enlargement.

A. This appears to be that position (indicating).

(Testimony of Robert T. Knapp.)

Q. Yes. Will you explain what you do and demonstrate the model to illustrate to the court how this Miller patent mechanism operates?

A. This shaft with a little turning disk on the end (indicating) represents the closed speed shaft coming out of the gear reduction.

Q. By that you are referring to the shaft—I don't know it is marked on this view. But at any rate,—

A. Shaft 52—no. No, this is the other mechanism on this end (indicating).

Q. At any rate, it is this knob which is mounted on the member?

A. Yes, this piece, we can look through the lucite and see the ball and socket joint. It corresponds to 69. This is the arm 68. This is an adjusting thumb screw 72.

Q. Now, will you move that member 68 and illustrate the movement?

A. This, of course, you see this revolves normally by the motor (indicating) and causes the machine to move as shown.

Q. As you move that from the position illustrated in the drawing, Exhibit G, what happens to the position of the pad or applicator 27?

A. Well, it moves on an arc about the pivot point 41, driven by this link 44 (indicating). [214]

I think this clearly shows the independence of these two links with this adjustable connecting lever. It moves on an arc, as you see, about this point (indicating).

(Testimony of Robert T. Knapp.)

This motion is a simple oscillation around this point with its time variation affected by these rather severe changes in angle involved in this link (indicating).

Q. And with the parts of the model in the position in the enlargement, Exhibit G, is the movement of the applicator or pad 27 on only one side of the vertical or does it move on two sides of the vertical line?

A. It is on one side of the vertical because this pivot point—wait a minute, now.

Yes, it is basically pivoted around this point—(indicating)——

Q. About the point——

A. About the point 39.

Q. 41, isn't it?

A. 41, yes. And thus any point that stays above this, vertically above a horizontal line going through this point will move only on an arc at one side of the vertical (indicating), no matter what complications we have in this mechanism.

Q. Now, by adjusting the model, Exhibit H, so as to put the pin 37 in the lowest notch 46 on the arm or link 44, and putting the pin at the upper end of that link 44 [215] in the right hand notch, the most right-hand notch 36 of the member 35, as so adjusted will you demonstrate to the court the operation of the device?

A. The motion is a shorter arc, as you will see, because moving this link 44 out to the extreme posi-

(Testimony of Robert T. Knapp.)

tion gives it the smallest arc possible with this mechanism.

But moving it up as far as it can on the vertical, to the last notch 46, it swings the arc of the pad to a more—more towards the vertical again.

Q. And in that movement what is the limit position of the pad relative to the limit position shown in the drawings, Exhibit G?

A. It projects considerably higher above the table at the upper limit.

Q. And farther toward one end of the table, is that right?

A. And farther toward, as I remember it, the foot of the table, yes.

Mr. Harris: If the court please, the enlargement, Exhibit G, is offered into evidence as Defendant's Exhibit of the same letter.

The Court: Received.

(The document heretofore marked Defendant's Exhibit G was received in evidence.) [216]

Mr. Harris: And the lucite model of the Miller patent, Exhibit H, is offered into evidence as Defendant's exhibit of the same letter.

The Court: Received.

(The model heretofore marked Defendant's Exhibit H was received in evidence.)

Q. (By Mr. Harris): Are you familiar with the contents of the Parker patent, No. 1,978,223?

A. I have a copy of this patent and I have read it. Again, I am familiar in general with what is contained in it.

(Testimony of Robert T. Knapp.)

Q. Will you please describe briefly and generally the construction shown and described in the Parker patent?

A. This patent again shows the operating mechanism built into a treatment table. The table is shown here as No. 13 with the head on the left-hand side, the headrest 14.

Q. First of all, Dr. Knapp, what are these two views, Figure 1 and Figure 2, of the Parker patent?

A. Figure 1 is a plan view looking down from the top with a portion of the top surface broken away to show some of the mechanism beneath.

Figure 2 is a vertical elevation in cross section so as to show the working mechanism.

Q. Yes. Now will you proceed with your explanation of the mechanism shown in those views?

A. The mechanism consists of a motor No. 33 and speed-changing [217] unit No. 32, with a belt drive from pulley 31 to pulley 28 in the vertical plane.

The motor and speed reducer is mounted on a base, the floor of the machine, and this device is mounted on the table top (indicating).

Q. By "this device" you mean the pulley arrangement 28 and 29?

A. The pulley arrangement carrying with it a slot which is, in effect, an adjustable throw cam, adjustable throw eccentric or crankshaft.

On this a pivot point 28b, which acts as an eccentric or crankshaft, to drive the member 27, which



(Testimony of Robert T. Knapp.)

is again a pitman or connecting rod, whose end is pivoted at 26 on a mechanism which is constrained to move only in the horizontal direction.

So that by operating the motor this rod 24 is caused to oscillate back and forth on again a very close approximation of simple harmonic motion.

Q. And what is connected to the left of the arm 24?

A. The arm 24 carries a long bar which is guided——

Q. Is that the bar 23?

A. The bar 23. ——which is guided by the rod 24 at the right-hand side and by a corresponding rod at the lefthand side; presumably 24 continued through guide bushings 25, the same number on both sides. This whole device then [218] oscillates back and forth in simple harmonic motion (indicating).

On this device there are pins which project horizontally, or rods which project horizontally that can engage each one in a mechanism whose number in general, I believe, is 18.

This is again an oscillating member of vertical support, which is pivoted at the lower end about a shaft 36, which remains fixed in the operation of the machine.

So these are all No. 36. The vertical position of 36 can be adjusted by a series of jacks, one under each of these operating supports, so that they can be varied, as is seen in the patent drawing, from a

(Testimony of Robert T. Knapp.)

low position, something like that (indicating), to a high position, like this (indicating).

Q. Is the construction of each of those supports illustrated in Figures 3 and 4 of the drawings of the Parker patent?

A. This is a drawing in detail of the construction of each arm support or applicator.

Q. First, as to the support shown in Figure 3, that is a view, is it not, similar, taken from the same position that the views are taken—

A. Yes.

Q. —in Figure 2 of the Parker patent?

A. This is enlarged view of any one of these applicators. [219]

Q. Then what is shown in Figure 4?

A. It is the view at 90 degrees, looking from, presumably from the head end of the machine—no, the foot end of the machine, the motor end of the machine.

Q. Of one of these applicators?

A. Of one of these applicators.

Q. Will you retrace a little bit the construction of that in more detail?

A. The jack which adjusts vertically the pivot shaft 36 is shown here with the jack screw 38 and the base 43.

This is the pivot point of the support member which consists of two arms (indicating). The rod 23, which we previously described—was previously numbered in 23—is the rod that oscillates back and forth by the pitman and the motor (indicating).

(Testimony of Robert T. Knapp.)

This rod goes through the two arms 45, through a slot which permits this vertical adjustment, the slot 18b, so that although the jack is operated, the motion of this will be always forced by the motion of the rod 23 (indicating).

Q. And what are these things 17 on the upper end of the upstanding arms or supports you have described (indicating)?

A. These are seemingly the applicators which contact the body of the patient. They contain, I believe, heating elements and provide heat as well as motion. [220]

Q. What is this screw that is numbered 34 in Figure 4 of the Parker drawing?

A. No. 34 is a screw which makes it possible to adjust the lateral separation of these two arms of this applicator; presumably to fit the body, I suppose (indicating).

Q. Going back for just a minute, in the Slenderella accused machines shown in Exhibits 16 and 17, is there any provision made for moving the pads towards or away from each other?

A. Yes. Each arm carries twin pads. The outer, speaking laterally from the axis of the machine, the outer pad is adjustable and can be—its separation from its mating pad can be adjusted over quite a wide range.

Q. And when this Parker machine is operated, what is the nature again of the motion of the vertical applicators 18 or 17, whichever we consider them?

(Testimony of Robert T. Knapp.)

A. The motion is again simple harmonic motion. From the way the drawing is built it is evident that they contemplated an oscillation symmetrical about the vertical. The crank is shown at 90 degrees when this is in vertical motion (indicating). So it means it would oscillate on both sides of the vertical, the amount controlled by the position of the pin 28b.

Q. Do I understand you to mean by adjusting the position of this pin 28b in its slot 28a, you can control [221] the length of throw or the arc of movement in each of these applicators 17?

A. That is correct.

Mr. Harris: If the court please, this enlargement of sheet 1 of the Parker patent No. 1,978,223, which the witness has been referring to, I offer into evidence as Defendant's Exhibit I next in order.

The Court: Received.

(The sheet referred to was marked Defendant's Exhibit I and was received in evidence.)

Q. (By Mr. Harris): Dr. Knapp, does this enlargement correctly illustrate, or is it a true enlargement of the corresponding sheet of the Parker patent?

A. So far as I can ascertain it is a true enlargement.

Mr. Harris: Next, if the court please, I produce a further lucite model, which I ask the clerk to mark as Defendant's Exhibit J for identification.

(The model referred to was marked Defendant's Exhibit J for identification.)

(Testimony of Robert T. Knapp.)

Q. (By Mr. Harris): Dr. Knapp, I show you this lucite model, Defendant's Exhibit J for identification.

Do you recognize that model?

A. It appears again to be a Keno-Matic model of the working parts of this Parker machine.

Q. The parts of the model correspond, do they, to the [222] parts shown in the enlargement, Exhibit I?

In other words, the parts of the model correspond, do they, to the parts on the enlargement?

A. We can demonstrate that by setting the model on top of the enlargement; setting this in this position, as shown (indicating).

Q. Do you have the parts of the model in position shown in the drawing?

A. They appear to be.

Q. Now, will you illustrate to the court just how this Parker machine operates?

A. This shaft that carries this disk is driven by the belt from the pulley on the speed changer 32 (indicating), so that when I turn this it is doing what the motor would do to the machine. And as this turns it will be seen that——

Q. First of all, what happens to the connecting rod 27?

A. Connecting rod 27 oscillates, this end oscillates (indicating). That is driven by the motion of the right-hand end around the crank circle. This describes again a very close approximation of simple harmonic motion, which is communicated to each of



(Testimony of Robert T. Knapp.)

these applicators by the pins, I take it, 40 (indicating), which project from the bar.

Mr. Lyon: 34, Doctor.

The Witness: 34. To the individual applicators. This [223] end, which may be confusing, this cross piece shown, is simply the handle at the outboard end of that pin (indicating).

Q. Those are for what purpose?

A. Those are for adjusting the separation shown here of the two applicators carried on the single arm.

The vertical motion of this is again, as I indicated from inspection of the drawing, a motion which is apparently symmetrical about the vertical.

And the top of these applicators (indicating) then moves in a small arc essentially oscillating about the horizontal.

Q. How does that motion of each of these applicators compare with the motion of applicators or pads in the defendant's accused machines?

A. I would say they were, for all intents and purposes, identical.

Mr. Harris: This lucite model is offered into evidence as Defendant's Exhibit J next in order.

The Court: Received.

(The model heretofore marked Defendant's Exhibit J was received in evidence.)

Q. (By Mr. Harris): Referring, first, to this Parker patent, Dr. Knapp, could the motion of the vertical applicators 17 be changed to approximate

(Testimony of Robert T. Knapp.)

that or to be the same as that of the Stauffer patent in suit? [224]

A. The position of, shall we say, the midpoint of the arc of the applicator is determined by the relative relationships of the parts. That is, we have to have the right length and the right position at this end and the right length here (indicating), in order to get this to oscillate about the vertical.

If, for example, this base 29, carrying the pulley and crank, were to be moved to the left the whole arc would be shifted more—with most of the arc on the left-hand side and less on the right-hand side of the vertical (indicating), and if the shift is continued, it could be easily carried, providing it didn't hit a portion of the machine, so that all of it was on one side of the vertical.

By shifting the base 29 in the opposite direction it could be made to be on the foot side of the vertical rather than the head.

Likewise, by changing the length of the member 24, leaving position 29 the same, it could be shifted in the same manner and, likewise, by shifting, changing the length of the connecting rod 27, it could be shifted.

Changing the position of the crank throw—changing the amplitude of the crank throw would do nothing toward changing the range of the arc. All of these other adjustments would modify it.

Q. In the Parker patent is there a slotway formed in [225] the top surface of the couch or table?

(Testimony of Robert T. Knapp.)

A. Yes, there is a slotway shown in Figure 1, presumably designated by 13a.

Q. And in Parker is there a vertically directed and oscillatable support for an applicator?

A. Yes, each of these members 18 would be so described.

Q. And there are six of those, are there not?

A. There are six of those shown here.

Q. In Parker there is, is there not, means to oscillate said applicators axially the length of the couch—strike that question. Excuse me.

In the Parker patent do the applicators move lengthwise of the table or couch?

A. The motion—the amplitude of the motion is lengthwise of the couch.

Mr. Harris: I don't know what your Honor's pleasure is. I will be a little while longer with this witness and I am sure Mr. Lyon will have some cross examination. I don't want to keep your Honor if you are——

The Court: Do I take that as a suggestion we adjourn?

Mr. Harris: Yes, your Honor.

The Court: All right. I will follow your suggestion. 1:30 tomorrow.

(Whereupon, at 4:20 o'clock p.m., Thursday, November 15, 1956, an adjournment was taken to Friday, November 16, 1956, at 1:30 o'clock p.m.) [226]

Friday, November 16, 1956—1:38 P.M.

The Court: All present. You may proceed.

Mr. Harris: The court please, at this time we offer in evidence Defendant's Exhibit C for identification as Defendant's Exhibit of the same letter.

The Court: Received.

(The document heretofore marked Defendant's Exhibit C was received in evidence.)

Mr. Harris: At this time we offer into evidence Exhibits D, D-1, D-2 and D-3 as Defendant's Exhibits of the same letters.

The Court: That is the prior art?

Mr. Harris: The prior art, yes, your Honor.

The Court: Received.

(The documents heretofore marked Defendant's Exhibits D, D-1, D-2 and D-3 were received in evidence.)

[See Book of Exhibits.]

### ROBERT T. KNAPP

called as a witness on behalf of the defendant, having been previously duly sworn, resumed the stand and testified further as follows:

#### Direct Examination—(Continued)

Q. (By Mr. Harris): Dr. Knapp, you explained yesterday certain differences in the movements of the applicator supports in the six [230] Sacro-Matic tables of the defendant, which you personally examined.

What, in your opinion, is the explanation for that variation that you described in the movement of those six table supports?

(Testimony of Robert T. Knapp.)

A. I would say that the primary reason for this difference is in the errors in construction in the machine. The frame of the machine and the frame of the mechanism are both made of welding pieces of standard structural shapes. These must be held in a jig or something of this kind while they are being welded, and the welding process causes warping and distortion, so that a certain reasonable tolerance has to be accepted in this.

Now, the construction of this, of the supports, in which the oscillation is relatively small, that is, of the order of three-quarters of an inch, and where the pitman is connected quite low down on a support, it only requires relatively a third or 40 per cent of the total motion of the top of the pad at the connecting point of the pitman. So that a small displacement there in the manufacture can cause the device to be, the arc of actuation to be moved on one side or the other a bit. It could be easily corrected if there was a point to it, but this seems to be all the required accuracy.

Q. What was the total amplitude of movement of the [231] applicator supports in the two types of defendant's machines which you have examined, in degrees?

A. In degrees the two movements, as I remember them, were approximately  $3\frac{1}{2}$  degrees in the Sacro-Matic and 3.9 degrees in the first machine.

Q. By "the first machine" you mean the Findlay, Ohio machine?

A. Findlay, I believe it is called.



(Testimony of Robert T. Knapp.)

Mr. Harris: Next, if the court please, I produce a card which I ask be marked for identification as Defendant's Exhibit K.

(The card referred to was marked Defendant's Exhibit K for identification.)

Q. (By Mr. Harris): Dr. Knapp, I hand you Exhibit K. Will you describe what that is and what it illustrates?

A. This is simply, shall we say, another Keno-Matic model of the vertical support which carries the applicator pad of this type of machine.

The rivet, the copper rivet at the bottom represents the pivot point. There is no connection to the pitman shown, just simply the vertical arm.

And the cross-hatched areas represent the arcs of movement.

Q. Of what?

A. Well, there are two sets. The ones that are [232] symmetrical around the vertical, two degrees on each side, represent what we can call the envelope of the movement of the two Slenderella machines.

In other words, it is slightly larger than the largest motion of either of the two machines, two degrees on each side of the vertical, moving as I am showing it moving now, oscillating it back and forth (indicating).

The larger cross-hatched sector represents the 10-degree arc described in the specifications of the Stauffer claims—not the claims, but the patent.

Q. The Stauffer patent in suit?

A. The Stauffer patent in suit. It is interesting

(Testimony of Robert T. Knapp.)

to note that the 5-degree minimum tilt from the vertical, called for in the Stauffer claim, makes the two sectors not overlap. In fact, there is a space between the two sectors of action that is as nearly as large as the motion of the Slenderella machine.

Mr. Harris: Thank you. This Keno-Matic model, as the Doctor described it, is offered in evidence as Defendant's Exhibit K.

The Court: Received.

(The card heretofore marked Defendant's Exhibit K was received in evidence.)

Q. (By Mr. Harris): Referring to the comparative drawing, which is Defendant's Exhibit C, does the view on [233] the right illustrate the pad on the top of one of the tables, defendant's tables, which you have examined?

A. It illustrates the end view of the two pads that are on each applicator.

Q. The end view or the side view?

A. Well, the side view looking at the machine normal to the longitudinal axis.

Q. Yes. What sort of a pad was on the other machine you examined, the machine illustrated by the right-hand view in this drawing, Exhibit C?

A. As far as I could determine they were identical.

Q. Thank you. I place before you Plaintiff's Exhibits 18 and 19.

The Court: There are now in evidence, are they?

Mr. Harris: Yes, your Honor.

Q. (By Mr. Harris): Do those, in your opinion,

(Testimony of Robert T. Knapp.)

accurately represent the nature of the movement of the applicator supports in either or both of the defendant's machines which you have examined?

A. I would say, to answer that specifically, they do represent accurately the movements. They represent the general type of movement.

Q. I show you the drawings, Plaintiff's Exhibits 16 and 17, Dr. Knapp. Are those production drawings, or what are they? [234]

A. No, I would say they are—this Exhibit 17, I would say, was an illustrative drawing for assembly purposes. It refers—it is a direction to an assembler how to put the pieces together. They are referred to as subassemblies, as you would expect on an assembly line, where we have many articles labeled "Subassembly G, Subassembly J," Subassembly so and so. It illustrates where to put them on the assembled table.

Q. Are drawings of this nature normally used by a manufacturer for the purpose of actual manufacture of the part?

A. No, no, they would be used only for assembly after the parts are manufactured.

Q. Is the same true of Plaintiff's Exhibit 16?

A. I would say this is more of an illustrative drawing, not meant particularly for assembly or for construction.

Mr. Lyon: Mr. Harris, are you attempting to impeach the drawings which you furnished at my request?

(Testimony of Robert T. Knapp.)

Mr. Harris: No, indeed. You asked me for drawings of the machines and I produced them.

Mr. Lyon: Are you now trying to say they don't represent the machines?

Mr. Harris: No. I just want to know what kind of drawings these are and that is what the witness has testified to.

The Court: Now, I would like to ask a question.

Mr. Harris: Certainly, your Honor.

The Court: To what extent may I safely look to Exhibits 18 and 19 in this case, and what will they show me if they are used to the fullest extent, as illustrations of portions of these structures?

The Witness: Well, I would say something of this nature (indicating). This is headed identification No. 18.

If we restrict ourselves only to this action and not to the oscillation of the table——

The Court: Yes.

The Witness: ——because we haven't discussed that, that this drawing seems to illustrate the general motion, with the exception that the amplitude is considerably greater than the amplitude of the machine. This looks to be not more than a full-scale drawing, but the angle——

Mr. Lyon: You mean model, don't you, Doctor?

The Witness: Full-scale model. I would just guess this is of the order of 12 inches (indicating).

The Court: Yes.

The Witness: But this amplitude is 50 per cent to 75 per cent greater than the amplitude I meas-

(Testimony of Robert T. Knapp.)

ured. So it swings on a bigger arc, but it does about the same thing.

The Court: Which swings on a greater arc?

The Witness: This vertical——

The Court: This 18—— [236]

The Witness: Exhibit 18, this vertical red support swings on a greater arc (indicating).

The Court: Thank you.

Q. (By Mr. Harris): A greater arc than what, if you please?

A. Than the actual Slenderella machine. On this one marked 19, which I believe is made to illustrate the Sacro-Matic table, the difference that I note in addition to it still swinging on a greater arc is that as I observe it it seems to only go slightly past the vertical on one side and considerably past the vertical on the other, which——

Mr. Lyon: At this point, Doctor, didn't you testify yesterday that several of the machines you measured at Slenderella, one of them was  $2\frac{3}{4}$  degrees one way and only  $\frac{1}{4}$  degree the other way?

Mr. Harris: The court please, Mr. Lyon is cross-examining now—or if it is helpful to you——

The Court: I think it is not quite the place to do it, Mr. Lyon. The court wasn't quite certain about these Exhibits 18 and 19, and I asked the witness to clarify my uncertainty, which he was doing, and you cut right in the midst of one of his sentences.

Can you find where he was at the time? We will let him finish that answer.



(Testimony of Robert T. Knapp.)

(The record was read.) [237]

The Witness: ———would not correspond to the information on those drawings. The information on the two drawings, from which these were presumably made, showed the member in the vertical position.

It is common practice on a symmetrical moving device you would show the member in mid-position. I think that discrepancies like this could be explained from trying to get accurate dimensions from these illustrative drawings, where the draftsman would have no reason to exert care enough for manufacture.

The Court: Drawings of this kind often occur, do they not, when the invention is still a brainchild of the inventor and has not been reduced to practice, so they are all in the early stage of the creation?

The Witness: Yes, you can express things in rough sketches, but when you do, you wish to convey to yourself a future idea, you usually use the conventions.

The Court: Yes.

The Witness: So, although they are not accurate to dimensions, they will illustrate to a person used to drawings and to yourself later on, if you are trying to remember something, a concept.

The Court: Yes. These cases are seldom decided immediately in the courtroom. The lawyers usually get this transcript and they ask me to read

(Testimony of Robert T. Knapp.)

it back, in the light of [238] arguments which they will submit in writing.

I wanted to have a little clarification, which you have now given me, regarding these exhibits, so I will be better prepared to cope with the arguments when they are presented.

Q.(By Mr. Harris): Dr. Knapp, do you have a copy of the Stauffer patent in suit before you?

A. Yes. I believe I have all the papers here.

Q. Do you have it? A. Yes.

Q. Have you read Claim 1 of the patent in suit?

A. Yes.

Q. And studied it with relation to the specifications and the drawings of the patent in suit?

A. Yes, I have.

Q. I call your attention to the words that appear in the sixth line of Claim 1 of the patent in suit, the words "tiltingly move."

What to you, as a man skilled in the art, do those words mean?

A. When I first read them I didn't know what they meant, because, like most English words, they could mean a variety of things. I tried to figure out what they meant from, first, the content of the claim, the rest of it, and then the contents of the specifications.

Assuming, since I am not a patent expert, but feeling [239] that patent procedure is pretty complicated, that words were probably used in rather narrow senses because of the necessity of distinguishing between things that are nearly alike,

(Testimony of Robert T. Knapp.)

so I went through some sort of a process like this:

Reading this applicator adapted "tiltingly move" in the previous part of the same sentence here it is supported on an oscillatable support. And then in the same sentence it says "\* \* \* means to oscillate said applicator \* \* \*"

So I assume that "tiltingly" could not mean simply oscillate, because it had been said twice before and that would make it very redundant.

Therefore, I went back to the specifications which describe the movement of the support, and thereby of the applicator, and found on page 2 at the end of the first paragraph, where it says:

"This arrangement causes the seat 18 to lie at a constant although variable angle with respect to the upper surface of the couch."

Preceding that it is said that the support moves between a probable maximum of 15 degrees from the vertical and an extreme forward motion of 5 degrees from the vertical on the other extreme.

And, furthermore, on the second column of this same page it specifies very clearly that the seat shall at no time pass the vertical. So I assume that this meant what it does [240] mean in geology. I looked it up in Webster's Unabridged and find that "tilt" or "tiltingly" means inclined to the vertical or the horizontal. So I assume that "tiltingly moved" meant it never became horizontal.

Q. Now, Dr. Knapp, I read you a quotation from Mr. Lyon's pretrial memorandum on file in this action, appearing on page 1, and I quote:

(Testimony of Robert T. Knapp.)

“The patent device is quite simple, consisting simply of a couch having an open section or slot in which is reciprocatedly mounted a flat applicator or pad to tiltingly move in the slot to manipulate or massage a portion of the body of the patient.”

Now, referring to the drawings of the Miller patent—one of the prior art patents in evidence here—does the device shown and described in the Miller patent, is that a couch or does it have a couch?

A. As I remember this, it is specified this unit 20 or 22 is a couch (indicating).

Q. And does that couch have an open sector slot?

A. Yes. I don't believe it has a number as such, but it is clearly shown here (indicating).

Q. Clearly in which figure of the drawings?

A. Figure 4.

Q. In that slot is there reciprocatingly mounted a flat applicator or pad? [241]

A. There is a flat applicator or pad mounted so it could oscillate. I assume that would be synonymous with reciprocate, the way it is meant.

Q. Well, I was simply asking you as to the structure. Does it have in the slot a flat applicator or pad? A. Yes.

Q. That is what element in Figure 4?

A. That is element 27.

Q. Does that applicator or pad in the Miller patent tiltingly move in the slot to manipulate or massage a portion of the body of a patient?

(Testimony of Robert T. Knapp.)

A. Yes, it tiltingly moves.

Mr. Harris: You may cross examine.

### Cross Examination

Q. (By Mr. Lyon): Dr. Knapp, how long has it been since you were instructor of mechanics?

A. Instructor of mechanics?

Q. Mechanism.

A. Mechanism was one of the earliest courses I was instructor in. Probably 25 years.

Q. Now, directing your attention to Exhibits 16 and 17, I believe it was your testimony that in one cycle of these devices, these two arms which are——

A. 11 and 11-A. [242]

Q. ——11 and 11-A are locked together by the clutch so that they move in unison, is that correct?

A. No, that is not correct.

Q. What is incorrect about it?

A. The arms themselves have no connection with each other at any time. They are driven by pitmen, individual pitmen, which—one pitman drives 11, one pitman drives 11-A.

These pitmen are caused to reciprocate by two separate eccentrics which are on a separate shaft. Not this shaft, but a shaft on another part of the machine (indicating).

Q. There is just one shaft, is that correct?

A. One shaft.

Q. There is just one belt that drives that shaft?

A. Just one belt that drives that shaft.

Q. Just one motor that drives that belt?



(Testimony of Robert T. Knapp.)

A. Yes.

Q. And that shaft then in one cycle—the first cycle, I believe you said,—drives these two supports 11 and 11-A in unison, is that correct?

A. Drives the two supports in unison, that is correct.

Q. If I laid a board across those four pads and we were in this first cycle so the supports 11 and 11-A are in unison, would you then say that that board which I have laid across the top is being caused to move axially of the couch? [243]

A. I would say the board could be considered to move axially along the couch.

Q. Now, on direct examination you stated you measured six of these tables. One of your measurements was  $2\frac{3}{4}$  degrees to one side and  $\frac{1}{2}$  degree to the other side, is that correct?

A. That is correct, as I remember it.

Q. You criticized these exhibits here, and particularly Exhibit 19, because it just goes a very little bit of the distance past the vertical on one side and maybe two or three degrees past the vertical on the other side.

Wouldn't that indicate to you that Exhibit 19 is a pretty fair exemplar in that regard, of at least the Slenderella table whose movements you measured and found to be  $2\frac{3}{4}$  degrees to one side and  $\frac{1}{2}$  degree to the other?

A. I would not consider it a good illustrative example of how the general table functioned.

Q. All right. Now, what is wrong with it?

(Testimony of Robert T. Knapp.)

A. Because it does not represent the typical movement. It represents one limit possibly observed in the manufacture. A model should represent what the machine is designed to do on the average, not the deviations in the manufacturing process.

Q. All right. If it differs from what it is supposed to be—actually, this Exhibit 19, I believe, is supposed [244] to be a model, Keno-Matic model illustrative of Exhibit 17.

You don't criticize Exhibit 19 because of anything in connection with this piece that is supposed to represent the table, do you (indicating)?

A. I don't criticize anything about it. That is not illustrating the exact motion.

Q. Let's see how many pieces there are. There is this main frame piece, the table piece (indicating)?

A. Yes.

Q. There is this red piece that comes up here, like this (indicating).

There is the pitman, there is the eccentric, and then there are the various centers (indicating).

If this Keno-Matic model is wrong, one of those must be wrong. Which one?

A. Your statement is not correct.

Q. I think it is your statement that is not correct.

A. No. I say that you just stated one of these must be wrong.

Q. That is right.

(Testimony of Robert T. Knapp.)

A. It could be one of several or it could be a combination of two or three.

Q. All right. At least one of them must be wrong if there is something wrong with the model, is that right?

A. I say at least one of them is not made accurately. [245]

Q. Show me which one isn't made accurately.

A. It can be one of three, at least three. This could be slightly too long, between this point and this point (indicating).

This position can be slightly to one side or the other, or this position can be slightly to one side or the other (indicating).

Just as I know this throw (indicating) is too great on this eccentric, any one of these in a very slight amount can do it (indicating).

In other words, this is a sloppy model which introduces errors which distort the concept of the machine. That is why I am criticizing it.

Q. You are not prepared—of course, you realize this is made out of wood, is that right?

A. Well, I hadn't examined it closely enough to be concerned. I think it is—it looks like plywood.

Q. I will tell you it is plywood.

A. I am sorry to criticize your workmanship.

Q. No, actually it is Mr. Nickerson's workmanship.

A. I think it was my student's workmanship.

Q. It was. I just helped sandpaper some of the pieces.

(Testimony of Robert T. Knapp.)

You are not willing to put your finger on any one thing and say that that is wrong, is that right?

A. I couldn't tell from this drawing, in the first place, because this is not a construction drawing, which one is wrong.

Q. So far as being representative of anything you can get out of this drawing, this might be actually the perfect Keno-Matic model, isn't that right?

A. I am sorry, but that is not so. If you are skilled in the art of using assembly drawings which follow the convention, you would get quite a different picture out of this than is represented here; not quite a different—but you would not, shall we say, you would not accept a model which shows a motion to one side or the other,—

Q. Doctor, have you ever—

A. —when this is a questionable element of the case.

Q. Doctor, have you ever in your life held a position in a factory where they were making and selling things generally to the public or to the Air Corps, or anything like that?

A. I think you could easily see from the records in the reference books I have been a professor most of my life.

Q. You know how Mr. Nickerson is an engineer in a manufacturing company, is that right?

A. Many of my students are engineers in manufacturing companies.

Q. Don't you think he knows how to read a drawing?

(Testimony of Robert T. Knapp.)

Mr. Harris: If the court please, this is simply argumentative. [247]

The Court: Sustained.

The Witness: Might I add that the questioning has shown I was consulting engineer for many companies of this type who manufactured for sale.

Q. (By Mr. Lyon): Yes, but the point is you aren't personally called upon to put things together from a drawing and never have been in your professional life, is that true?

A. This is not true. I am an experimental research man. I have quite an elaborate shop of my own. My father was an operating engineer. I have done shop work all of my life. I went through the Los Angeles school system, through a very famous high school called the Polytechnic High School, which I took shop work of all types for four years.

The Court: The Polytechnic High School in Los Angeles?

The Witness: That is right, sir.

The Court: I still remember how it smelled around there, the odors of the foundries and things of that kind, some forty years ago.

The Witness: That was a wonderful development of Dr. Francis.

The Court: In that day it was strictly a polytechnic school.

The Witness: Yes.

Q. (By Mr. Lyon): Doctor, I believe you stated that the [248] motion which is intended to be illus-



(Testimony of Robert T. Knapp.)

trated by Exhibit C was different than any motion we found in any of the Slenderella tables that you examined, is that correct?

A. Let's see, which is Exhibit C?

Q. It is before you.

A. The only thing I remember stating about this, that is different from the Slenderella motions, was that the amplitude again was larger than any I measured.

Q. Yet that amplitude is supposed to represent what you would get if you were building what is shown in Exhibit 17, isn't that correct?

A. It probably represents what the draftsman measured from that drawing, which, as I said, was not a construction drawing and it might have shown a slightly larger amplitude here (indicating).

If you try to scale this drawing and then multiply it by the factor to bring it up here (indicating), you will find if you look at the division lines on a scale it would be rather difficult to estimate that closely.

Q. Comparing the motion of Exhibit C, the right-hand part of Exhibit C, and the motion of Exhibit 18, how do they compare?

A. Well, Exhibit C goes according to the convention and shows the oscillation taking place on equal sides of the vertical center line. This one does not. [249]

I am not making a severe criticism of this. I am saying it is distorted in a way which I do not think is correct, to bring into a case of this kind, when

(Testimony of Robert T. Knapp.)

this kind of an angle is a part of the thing in question.

Q. Now, this angle between the pitman and the vertical support—— A. Yes.

Q. ——not being 90 degrees, doesn't that indicate to you that of necessity there is going to be a greater movement to one side of the vertical than the other?

A. It does not. I shuddered when I heard my student say that; ex-student, I should say, I am sorry.

I think if counsel would note that if he would simply shove this whole bearing this way (indicating), he could make the thing oscillate on this side completely (indicating).

If he pulled it this way, he could make it oscillate on this side (indicating). If he would take care he could make it oscillate evenly around the center (indicating).

Q. That is correct. But beginning with the drawings we are supposed to be depicting in this device, Exhibit 18 is supposed to be——

A. One number is on one end and one on the other.

Q. I want 16. A. 16?

Q. No, this is 17, that is correct. This drawing with [250] the support being straight up in the air—I am talking about Section CC,——

A. Yes.

Q. ——the maximum eccentricity is straight down, right?

(Testimony of Robert T. Knapp.)

A. No. I don't know; this kind of a drawing I cannot tell on.

The Court: Would that make any difference under Claim 1 of this patent?

Mr. Lyon: I don't think so, sir, but what I am doing now is I am defending my exhibits. I am not worrying about the patent.

The Court: But I am. That is what I have to decide, the patent and the accused structure, and it seems to the court that the claim of the patent does not call for all of this elaboration of matters which might be one way or the other and still be within that claim.

Mr. Lyon: I agree with you. I won't belabor that any more.

Q. (By Mr. Lyon): Dr. Knapp, you said that the motion in the Stauffer patent was not a simple harmonic motion.

Do you care to make any statement as to how far it differs from a simple harmonic motion?

A. I would be glad to. Would you mind removing some of this stuff if you are not going to refer to it again, so I can get to my papers? [251]

Q. Yes.

A. I will try to make one more attempt to be a little clearer about what is simple harmonic motion. Another way of looking at it is we can say it is something of this nature (indicating).

The Court: You are going to do some drawing now? It looks as if you are.

The Witness: If I may.

(Testimony of Robert T. Knapp.)

The Court: You certainly may. But let's get it upon something we can retain here as an exhibit in the case.

Will the lines on here bother you (indicating)?

The Witness: No, I don't think so.

The Court: All right.

The Witness: My drawing of a circle would be so crude that—if we have a circle of this type (indicating), all we really need is a point moving in a circular path at a constant speed.

If this point—shall we call this point  $A$ —moving at a constant radius  $R$ , around the center  $C$  continuously, as it moves up here a given angle (indicating), if we would simply drop a perpendicular line down to a point on the diameter, and do this at each instant of time, as it goes around, then the trace of this point along the diameter (indicating) would represent simple harmonic motion.

In other words, it is the component of the motion of [252] this point in the direction of the diameter (indicating), when the point is going at a constant speed at all times.

When it is starting from this point (indicating) it is going straight up, the motion of the point of the diameter is zero. When it is at the top the motion is in the direction of the diameter, so the velocity is the greatest at this point (indicating).

As it comes down here the component gets less and less, until it comes back down here there is no motion, so this point oscillates back and forth here

(Testimony of Robert T. Knapp.)

(indicating), going the slowest at the two ends and the fastest in the middle.

Whereas, the acceleration is the greatest, forcing it to start from a stop here, moving in a direction toward the center, is the greatest at the outside and is zero in the center (indicating). This motion is called simple harmonic motion. It is a motion which we get approximately when we put a crank pin on here and connecting rod, and cause this end to move in a straight line (indicating).

It would be exactly the same if, instead of a connecting rod, we had a slot, like this (indicating), with a rod and this pin would fit snugly in the slot and would drive this rod back and forth (indicating).

The only difference is a slight difference due to the arc, the length of the connecting rod here (indicating), this point, which is on a diameter that corresponds—on the arc [253] —to a point a little bit advanced.

That is why we say it is, it differs slightly or more greatly from simple harmonic motion, as some of these distortions come into the picture.

Q. (By Mr. Lyon): Isn't another way of expressing that same thing, that simple harmonic motion, that it is the motion of a true pendulum?

A. A true pendulum, the motion of the true pendulum follows simple harmonic motion, but not in this picture.

Q. That is right. Now, will you explain the de-



(Testimony of Robert T. Knapp.)

gree of difference in the Stauffer patent mechanism?

A. I didn't make this drawing to become an exhibit, because it needs interpretation to know what my different sets of figures mean on here, but it is pretty evident from it what we are talking about.

Simple harmonic motion, the time required to make a half circle is the same as the time required to make the other half circle (indicating). That is, the two sides of the motion are symmetrical, going and coming, or shall we say from here around to here is the same as from here around to here, if we take the two extremes (indicating).

This is one of the prime characteristics of simple harmonic motion. We can have other motions that do that, but all simple harmonic motions have to do that. They have to be symmetrical, so that we could describe a degree of distortion [254] from simple harmonic motion by saying how much time it would require to go half the way around, compared with the time it required to go the other half the way around. That is what I tried to plot in the case of this Stauffer machine, from my rough picture.

What it amounts to is that this is the center line of the motion (indicating), and I have one, two, three, four, five, six large squares—this is time I am plotting along here (indicating)—represents the time required for simple harmonic motion to do a half cycle.

(Testimony of Robert T. Knapp.)

This light curve which I have here (indicating) is the Stauffer motion, and it is one, two, three, four one-half—well, it is approximately one more square. So that the Stauffer on this half, shall we say, (indicating), takes about  $7/12$ ths of the time and  $5/12$ ths of the time to go the other way.

Q. Which Stauffer?

A. This is the one that is labeled "Stauffer" (indicating).

Q. You say that is four. I count six.

A. The extra time required by the Stauffer machine, to go the same distance—extra time—it is the original time of the simple harmonic motion, plus this distance, plus this distance (indicating).

I was counting small squares. There are five small [255] squares and one large one in here (indicating). One, two, three and about a half.

Over here we have one and about a half (indicating); slightly less.

So I was saying this, plus this (indicating), is equal to one big square. There are six big squares. That makes seven big squares represent the time of the Stauffer to go one-half of the way on its cycle, and five squares then would represent the other half because there are 12 to make the whole business. So  $7/12$ ths to  $5/12$ ths is a very appreciable distortion of simple harmonic motion.

This gives a jerk. If you were experiencing this motion you would feel it as a jerky motion. That is why I referred to it as a quick return motion as used in machine tools.

(Testimony of Robert T. Knapp.)

Q. Dr. Knapp, in describing the Gunderman patent you noted that there was no gear reduction, is that correct?

A. Being an absent-minded professor I prefer to look at the patent.

Q. Here it is.           A. Yes.

Q. There is no gear reduction?

A. I said I believe that unit 10 was a motor drive of unspecified type.

I don't believe I said there was no gear reduction, because I have no way of knowing. [256]

Q. Well, there is no gear reduction shown. Put it that way.

A. To my knowledge, for something like thirty years, motor manufacturers have made motors with integral gear reduction.

From the end view of a schematic drawing like this they would look just like that (indicating).

Q. Is it your opinion that the Gunderman patent intended to have a motor with built-in gear reduction?

A. I often wanted an Ouija board, but I have never found one.

Q. You know it is a fact, do you not, that Gunderman is a vibrating machine? It says so right there (indicating), doesn't it?

A. "Portable Vibrating Machine."

Q. And in this art, when they want vibration, do you have any idea what the rate of vibration is?

A. No, I know nothing about the process of removing excess weight or massaging people.

(Testimony of Robert T. Knapp.)

Q. But you are an expert on the patent here before the court, are you not?

A. I am trying to discuss the mechanical motion. I am certainly not discussing what the machine does to the human body.

Q. I am not asking you that. I am asking you if you [257] know what is the rate or range of rates in this art that we are operating in, and we are talking about vibration.

A. I have no knowledge of that. I know in some of the very early patents I read that the machine could be operated from 50 to 200 for one purpose and from, I think, 1,000 oscillations up for another purpose. I don't remember what they were. So I would say it would cover quite a wide range.

Q. Have you read the Miller patent, No. 1,953,424?

A. I have read all of these three patents at one time.

Q. I call your attention to the first paragraph on page 4 of the specifications of the Miller patent, the first full sentence reading:

“The operation of the motor causes the link, to which the strap is attached, to reciprocate rapidly, thus imparting to the strap a vibrating motion, the vibrations being equivalent to the speed of the motor which is preferably about 1,700 R.P.M.”

Now, does that indicate to you that when they want a vibrating machine, as distinguished from a manipulating or a massaging machine, that there would be no gear reduction employed?

(Testimony of Robert T. Knapp.)

A. It indicates to me that Mr. Miller was considering his machine to be operated at 1,700 R.P.M. and causing vibrations of that frequency. Beyond that it doesn't give me any [258] ideas.

Q. Using that as a clue, it would give you an idea that certainly Mr. Gunderman didn't want any gear reduction in his vibrating machine?

Motors about the time, January 29, 1929, generally ran at 1,700 R.P.M., didn't they?

A. This was one of the common speeds. There are quite a few. I have had occasion to use quite a few motors. It is never 1,700. It is a slip from 1,800, depending upon the efficiency of the motor. Usually about 1,760.

Q. Now, turning our attention again to Gunderman, the top of the element 26 is curved, is it not?

A. Yes.

Q. Do you know what the center radius curvature of that curve is?

A. No, I haven't checked it. To my eye it would appear, oh, somewhere around the pivot point 40.

Q. You demonstrated a model yesterday—supposed to be a model, Keno-Matic model—of this device? A. Yes.

Q. And you noted that when you turned it that the unit 26 followed the outline very accurately, isn't that right?

A. I didn't notice exactly. As I say, I think it appears about that. I could easily check it on the model. [259]



(Testimony of Robert T. Knapp.)

Q. Well, we will do that.

A. I would say within the limits of accuracy of the drawing that this is pivoted around this point (indicating).

Q. So that is fair to say, is it not, Doctor, that there is no lifting action imparted by the operation of the Gunderman device to anything resting upon the member 26?

A. I would have to ask you what you mean by "lifting." Let me illustrate——

Q. There is no component force in the vertical direction, is there?

A. If you are talking about a rigid body that this slides underneath, I would say there is no lifting action. A rigid body will not move up or down.

Q. Now, did you make these models?

A. No.

Q. Do you know who did?

A. I have heard the name. I do not know the person, I have never seen him.

Q. I show you the Keno-Matic model, Defendant's Exhibit H, of the Miller patent. A. Yes.

Q. In direct testimony I believe you stated that the pad 27 of Miller is adjustable about the pivot 32. What do you mean by "adjustable?"

A. Movable. [260]

Q. Freely movable, isn't it?

A. I have no idea. From what this shows it could be on a clamping screw or it could be on a free pivot or it could be on a tight one; I don't know.

Q. Have you read the specification?

(Testimony of Robert T. Knapp.)

A. I would have to look to refresh my mind on that detail.

Q. I will refresh your mind. On page 2, column 1, of the Miller patent, No. 1,953,424, appears the following:

“The purpose of the pivoted joint between the pad 27 and the clip 31 is to allow the pad to adjust itself to the body when in operative position.”

Now, wouldn't that indicate to you it was a free pivot?

A. It would indicate to me it was not clamped.

Q. That is right.

A. It could be free or not; tight.

Q. It is proper to say then this mechanism here is articulated, isn't it?

A. I think we could say that——

Q. All right.

A. ——not quite knowing what the word means.

Q. When you have such an articulated system and you move this through a degree, causing that to rise (indicating), and there is a heavy object on the top of this pad 27 (indicating), that pivoting will permit the link arm between the [261] pivot 32 and the top of the pad 27 to turn, as this link 35 (indicating) is raised, so that the resultant is a movement in a straight line upward of the pad 27, isn't that correct?

A. If I would—how shall I say it—build a rigid structure on the pad 32——

Q. Suppose there is a man's back sitting there.

(Testimony of Robert T. Knapp.)

A. A man's back? I wouldn't have much of any idea, because it is a very flexible sort of a thing, like a sack of sawdust. I wouldn't know what—

Q. If there was a man's back on this, in the first place the pad would be flat to conform to his back, in accordance with what I just read in the patent, wouldn't it?

It would adjust itself to his back because of the pivot?

A. Yes, it wouldn't be flat. I should say my back isn't flat, from what I can remember of it.

Q. All right. As we pivot the link 35 counterclockwise and the end of that pivot tends to traverse somewhat to the left, that will be compensated for by a pivoting of the member 27 in a clockwise direction, will it not? That is engaging—

A. Are we talking about relative or absolute motions? I mean, are we riding on this arm 33, or are we looking at it as we stand or as we feel it as if our back were against this pad?

This relative and absolute motion is a mess. I don't [262] quite see what you are after.

Q. What I am getting at, Doctor, is if there is a man's back here (indicating), and you raise the link 35, or, 33, vertically,—I mean pivot it in a counterclockwise direction, a man's back pressing upon the pad 27 will cause the pad to have a relative motion about the pivot point 32?

A. A relative motion—

Q. In a clockwise direction.

(Testimony of Robert T. Knapp.)

A. In a clockwise direction? If we pile all these ifs together, yes.

Q. The only if is a man with his back on it.

A. Rigid back?

Q. Yes.

A. I don't know what a man's back would do. That, as I say, I am not a physician or a physical culture man.

Q. As a practical matter then, what happens is that the pad is merely pushed upward, isn't that correct?

A. I think as a practical matter the motion is pretty complicated, because this pivot point 32 is going to move in an arc.

I think the whole business is going to slide on the man's back because I think you have too many motions.

Q. There may be some slide, Doctor. But isn't this main motion just an upward push?

A. I think the main motion is a push along this arc [263] (indicating).

Q. The patent, I believe, again gives us a light on that, I think, Doctor. It says on page 3, column 1, about line 17:

“When the motor is started it creates a pulling action on the straps which has the effect of imparting a contracting and expanding manipulation to the chest and abdomen and at the same time produces an upwardly pressing movement against the spine.”

(Testimony of Robert T. Knapp.)

So the patentee thinks he is getting an upwardly pressing movement, isn't that right?

A. I would say the patentee thinks he is getting an upwardly pressing movement.

Q. Again, in the same paragraph, a few lines later:

“The chest and back pads 28 and 27, respectively, operate in unison, that is, as the chest straps are pulled downwardly to contract the chest, the back pad 27 simultaneously presses upwardly against the spine.”

So we have that same concept repeated twice there.

A. I don't know what the strict meaning of the word “upwardly” is. I could say in an approximate vertical direction.

What the man says and what this motion does may be two different things, just as in the Stauffer patent. I cannot give testimony on what the man says. [264]

Q. With respect to Exhibit K, how did you happen to pick two degrees on each side of the Slenderella motion?

A. I picked the two degrees on each side on the Slenderella motion because in measuring up the five units of the one type of machine and the one unit of the other, I saw that the total motion was less than four degrees, and that the average motion was symmetrical about the vertical.

So I suggested that this be made to show an arc



(Testimony of Robert T. Knapp.)

that would include the widest motion for which either machine was designed to operate.

Q. Of course, actually, Exhibit K does not conform to any of the machines you saw, does it?

A. No. The arc is slightly larger than any of the machines. This was not a Keno-Matic model of the machine, as you remember.

Q. Referring again to this Miller patent and comparing it to any of the others here in evidence, Gunderman, Parker, or to the patent in suit, the pivot of the arm 35 is about point 41, isn't it?

A. Yes.

Q. And the arm extends from the point 41 at an acute angle of the horizontal, does it not?

A. Yes, at an angle to the horizontal. I don't know what you mean by "acute" here.

Q. You know the difference between an acute and obtuse [265] angle?      A. It is an angle.

Q. It is a small angle with a variable.

A. You said from the horizontal.

Q. From the horizontal, that is what I meant.

A. I was trying to decide whether it was this angle or this angle (indicating). You said an angle from the horizontal. I think that is sufficient.

Q. All the rest of these devices have got the pivot point down at the bottom, haven't they?

A. As I remember it, one version of Gunderman has the pivot point in the middle.

Q. Well, the pivot point is directly below the maximum height of the device. In other words,

(Testimony of Robert T. Knapp.)

directly below the applicator when it is in the vertical position.

That is true in Parker, that is true in Gunderman and it is true in Stauffer, is it not?

A. Except the Stauffer specifies that it never gets in the vertical position.

Q. All right. My point is that in Miller we are operating on this cycle of an arc, wherein most of the motion is vertical, where the vertical component of the motion is much greater than the horizontal component.

Whereas, in all these other devices, we are operating on this part of the arc (indicating), wherein the horizontal [266] component is much greater than the vertical.

That is a fair statement, is it not, Doctor?

A. In this connection I think I would have to call your attention to the fact that the angle which is important has nothing to do particularly with the arm 35. The angle which is important is the angle between the point 41 and the applicator 32.

Q. Doctor, I asked you if it wasn't true, if it wasn't a fair statement, that in Gunderman, Parker and Stauffer we are operating on the part of the arc being more nearly directly above the pivot point.

Whereas, in Miller we are operating on the part of the arc more nearly directly disposed horizontally, aside from the pivot point, so that in Gunderman, Parker and Stauffer we are operating it on an arc which has a larger component of motion in a horizontal direction.

Whereas, in Miller we are operating in an arc

(Testimony of Robert T. Knapp.)

which has a larger component of motion in the vertical direction. Is that not a fair statement?

A. Mr. Lyon, I am not trying to quibble. I am trying to bring out a point which I think is confused here, and that is that the motion we are concerned with is the motion of the applicator.

I could draw a support for one of these others in which the arm would start out horizontal and come around with a [267] curve to this other, and we would get the same motion, so that I have to go back to the arc from the point 41 to some point on the applicator, to find out what it is all about.

Mr. Lyon: No further cross examination.

Mr. Harris: No redirect, your Honor. May the witness be excused?

The Court: The witness is excused.

(Witness excused.)

The Court: Mr. Clerk, call our 3:00 o'clock case, and in between witnesses of this case will be a good time to handle a further pretrial. In the case on trial, Stauffer v. Slenderella, we will take a ten-minute recess.

(Whereupon, a recess was taken from 2:50 o'clock p.m. to 3:25 o'clock p.m.)

Mr. Harris: If the court please, at this time I would like to offer some further patents. These are the file wrapper references which were considered by the United States Patent Office in connection with its consideration of the Stauffer patent in suit. I shall identify them.

First, for identification as Defendant's Exhibit

L-1 is a patent, a U. S. patent to Taylor, No. 86,604;

Next, as Defendant's Exhibit L-2 is a patent to Hardy and Gibson, No. 1,276,526;

Next is a patent to Hardy, No. 1,391,893, which would be Exhibit L-3; [268]

Next is a patent to Iverson, No. 1,602,196, which would be Defendant's Exhibit L-4;

Next is a patent to Rosenquist, No. 1,616,065, which would be Defendant's Exhibit L-5;

Next is a patent to Torrence, No. 1,910,135, which would be Defendant's Exhibit L-6;—

Mr. Lyon: Does that complete the list?

Mr. Harris: No.

Next is a patent to Hardy, No. 1,999,412, which would be Defendant's Exhibit L-7;

Next is a patent to Snyder, No. 2,036,371, which would be Defendant's Exhibit L-8.

(The documents referred to were marked Defendant's Exhibits L-1 to L-8, inclusive, for identification.)

Mr. Harris: I offer those into evidence at this time on behalf of the defendant.

Mr. Lyon: If the purpose of this offer can be limited to merely showing what was before the Patent Office, I have no objection, but if the patents are to be received without limitation, I object to the receipt of the patents on the ground we have had no notice as required by law. They cannot be considered on the question of invalidity of patent.

Mr. Harris: We offer them generally, if the court please, because, of course, the plaintiff has

had notice of these patents—they are part of his file wrapper—since he got [269] his patent.

We offer them for any purpose. We are not going to adduce any testimony with relation to them, but we offer them for any purpose.

Mr. Lyon: Well, the law requires the defendant to give the plaintiff notice 30 days in advance of trial of any patent which it is going to rely upon. I have never even seen those patents.

Mr. Harris: Subject to, of course, any direction from the court. In other words, it is within the court's jurisdiction, under the statute, to admit the patents if the court believes they are relevant and if the plaintiff or its counsel have had notice of patents as such.

The provision of the statute is merely to provide that the plaintiff in a patent case shall have had notice of the patent prior to trial. And, of course, these patents, having been cited in connection with his application, he has had notice since 1938.

Mr. Lyon: You are perfectly aware that is no notice you intend to rely on those patents.

The Court: Are they cited in the Stauffer—

Mr. Harris: In the Stauffer file wrapper, yes, your Honor. They are all cited in the Stauffer application file wrapper.

Mr. Lyon: If the receipt of these patents can be limited, [270] having before the court and showing the court the art considered by the Patent Office, I have no objection.

If it is not so limited, I do, and insist my objection is well taken.



The Court: We will admit them and limit, as Mr. Lyon suggests, at this time. I am inclined to think that limitation should be removed. I just want to check in some authoritative work before allowing them in generally, because it does appear that it is unnecessary to give a person notice of that of which he is already informed.

Mr. Harris: Yes, your Honor. Thank you.

The Court: Of course, he isn't informed specifically that you are going to rely upon these. Apparently the patent examiner didn't rely on them. He considered them and rejected them as anticipations.

Mr. Harris: Well, he used them very widely in considering the Stauffer application for a patent and Mr. Stauffer's attorney amended the application repeatedly to avoid the rejection of his claims upon these very patents.

I might say that also there is one more file wrapper reference which I haven't offered in this group, and that is the Parker patent, which is already in evidence in the case. There is no point in encumbering the record with another copy of that same patent.

The Court: They are received and will be received for [271] the limited purpose indicated, until and unless the court makes further order.

(The documents heretofore marked Defendant's Exhibits L-1 to L-8, inclusive, were received in evidence.)

[See Book of Exhibits.]

Mr. Cox: Dr. Fishbein.

## WILLIAM I. FISHBEIN

called as a witness on behalf of the defendant, having been first duly sworn, was examined and testified as follows:

The Clerk: Please take the stand.

Will you state your name, sir?

The Witness: William I. Fishbein.

## Direct Examination

Q. (By Mr. Cox): What is your address, Dr. Fishbein?

A. 7853 South Shore Drive, Chicago, Illinois.

Q. Are you a licensed physician?

A. I am in the State of Illinois.

Q. Would you please state briefly, Dr. Fishbein, your academic record.

A. I graduated from the University of Chicago in 1921, bachelor of science; from Rush Medical College in 1923, Doctor of Medicine. I interned for two years at Michael Reese Hospital in Chicago.

From 1925 to 1931 I was school physician, part-time physician with the laboratory schools of the University of [272] Chicago, and also engaged in private practice during that period.

From 1931 until 1935 I also was in general practice and was working part time at the Chicago Board of Health.

Q. I just asked you at the moment for your academic background. A. Oh.

Q. Following 1935, Dr. Fishbein, what has been your experience in the field of medicine? I think you related it up to 1935.

(Testimony of William I. Fishbein.)

A. From 1931 to 1935 I was acting as director of surveys in the Chicago Board of Health. And from 1935 until 1956 I was the epidemiologist for the Chicago Board of Health. At the same time I was acting as consultant for a number of commercial firms, pharmaceutical houses, including Abbott Laboratories, McKesson-Robbins, Belchio Corporation, Chilean Idene Educational Bureau, International Latex Corporation, among others.

Q. Are you a member of any medical associations?

A. I am a member of the Chicago Medical Society, the Illinois State Society, the American Medical Association, the American Public Health Association.

Q. Dr. Fishbein, are you employed by the defendant in this case, Slenderella Systems of California, Inc.?

A. No, I am not. [273]

Q. Have you been employed or connected in any sense with any Slenderella companies related to the defendant?

A. Yes, I have been a part-time consultant with Slenderella; I think the home office is in Stanford, Connecticut.

Q. Are you familiar, Dr. Fishbein, with the two Slenderella tables which are illustrated in this case by—

A. Yes, I am.

Q. —Exhibits 16 and 17?

A. I am quite familiar—

Q. You might wait until I finish my question.

(Testimony of William I. Fishbein.)

A. O.K. I am quite familiar with the operation of the tables.

Q. From your observation of the two tables, Doctor, would you say the external movements of the tables are identical or substantially identical?

A. Yes, from my observations I believe that the motion imparted to the pads at the top is the same in both types.

Q. As a matter of fact, there are three separate and distinct motions to the Slenderella table, are there not?      A. Yes, sir.

Q. One, a motion backward and forward of the entire top of the table; and secondly, an alternating motion of the two pads inserted in the top of the table, and thirdly, the two pads moving in unison back and forth on top of the table? [274]

A. That is correct, those are the three motions.

Q. In the following questions, Dr. Fishbein, I am going to advert exclusively to this last mentioned motion, which is the two pads moving in unison within the top of the table. And for purposes of convenience I will refer simply to the Slenderella table, in the singular, is that clear?      A. Yes.

Q. Can you describe briefly what your experience has been in connection with the Slenderella table?

A. During 1955 and part of 1956 I made a study of 50 women who took regular treatments on the Slenderella tables. We conducted the study to determine what effects we might get, exclusive of any

(Testimony of William I. Fishbein.)

dietary regulation, so that these women continued with their regular dietary practices.

They visited the office. These were not conducted in the salon, but in the physician's office, away from the salons. They visited the salons two or three times a week. At the end of a six-month period we had obtained an average weight loss in the neighborhood of seven to eight pounds, and a change in the abdominal measurement of about 2½ inches.

The Court: Without diet?

The Witness: No dietary regulations at the time.

Q. (By Mr. Cox): Is your familiarity with the table, Doctor, sufficient to enable you to form a medical opinion as to the effect of the table upon users? [275]

A. I believe that it is. I have observed enough women using the table and made enough studies to determine what effects we are getting.

In addition, we are now conducting a second study to determine if we get any improvements in muscle strength. Those studies are only in progress and I can't make any statement now about the result we may get.

Q. Have you had occasion to read the specifications and claims of the patent in suit, with particular reference to the medical and therapeutic and physical claims made by the patentee Mr. Stauffer?

A. Yes, I have.

Q. The following questions, Dr. Fishbein, are going to relate to those physical and therapeutic



(Testimony of William I. Fishbein.)

claims to the patent in suit, as related to the Slenderella table.

In your opinion, is the defendant's table capable of alleviating pain due to nerve stricture arising from maladjustment of any of the vertebrae by the user?

A. I would not believe that it would have that effect, and I would be very fearful that it might make such pains worse, rather than better, because if there is pressure on nerve roots, on the nerves as they come from the spine, the spinal cord, any compression or movement of the spine in any direction would be apt to make such pains worse, to increase the pressure on the roots, and certainly would not be [276] advocated.

Q. Is the Slenderella table capable of alleviating pain by the massage of any of the muscles of the spinal tract?

A. Since the Slenderella table is not designed for massaging, it couldn't do anything in the nature of massaging.

Q. In particular is defendant's machine capable of alleviating pain by the massage of the erector spinae, or the semispinalis, multifidus or latissimus dorsi?

A. No, the table doesn't produce massage and, therefore, would not have any effect in relieving pain by a process of massage.

Q. In your opinion is the defendant's table capable of alleviating strictures in whole or in part?

(Testimony of William I. Fishbein.)

A. No, it would not alleviate any, any pressure effects that were occurring on nerve roots.

Q. In your opinion is the defendant's table capable of alleviating pain or discomfort due to pain from sagging or fallen internal organs.

A. Inasmuch as the table only gives exercise, it certainly could not alleviate any pains that were due to displacement of the intra-abdominal contents.

Q. Is the defendant's machine capable of strengthening any of the abdominal muscles of a user?

A. That is the point that we are trying to determine now by actual measurement. [277]

Now, since the table does have an effect of producing passive exercise and exercise is known to strengthen muscles, it is quite possible that some effect would be produced.

But until we have the exact evidence I would hesitate to say whether it could or it could not.

Q. That is the subject of the tests being presently conducted? A. At the present time.

Q. Is the defendant's table capable of a strong and repetitious differential of lifting or upstroking of muscles?

A. No, the machine doesn't operate that way. There is no lifting or upstroking. There is merely a—I think probably would best be described as a shaking.

Q. Is the defendant's table capable of relieving tension created by the stretching of any organs or supporting tissue?

(Testimony of William I. Fishbein.)

A. No, the effect is only on the muscle groups and those are the external muscles of the body.

Q. In your opinion is the defendant's machine capable of permitting such tissue and correlated muscular support to regain any lost strength?

A. Since it doesn't have any effect on them, it certainly couldn't alter their structure in any way.

Q. Does the Slenderella table tend to place any of the internal organs in a normal position after having been [278] removed from such normal position by reason of any weakening of the supporting tissue therefor?

A. No, I don't believe there is any table or any kind of exercise that would do that. I think it would probably require some surgery.

Q. In your opinion does the use of the Slenderella table alleviate pain and distress due to strictured nerves and blood supply?

A. Again, since, in order to relieve pressure on strictured nerves you would have to have constant stretching of the spine, I don't think that we would attain it with the Slenderella table.

Now, strictures of the blood supply are rare, without the development of gangrene, since if you cut off the blood supply the tissues will surely die.

I can't imagine any state where the blood supply has been cut off and any physician would rely on exercise to restore it.

Q. In particular will the defendant's table alleviate pain and distress due to stricture of the

(Testimony of William I. Fishbein.)

nerves and blood supply resulting from maladjusted vertebrae?

A. No, I think that the chances would be that we would only further maladjust maladjusted vertebrae.

The motion is contraindicated when we have dislocations of the vertebrae or when there is a protrusion or injury of [279] one of the intervertebral disks. The motion is contraindicated and would be harmful.

Q. In the use of the defendant's table is the movement of the pads thereon imparted to a body lying thereon accentuated in that its greatest thrust or lifting is in one direction only?

A. Would you read that again?

Q. In the use of the defendant's table is the movement of the pads thereon imparted to a body lying on the table accentuated in that its greatest thrust or lift is in one direction only?

A. Not by any means. The motion is equal in both directions and there is no lift.

I don't know whether you would call shaking a thrust in both directions. I suppose it would be possible to consider it that way.

Q. In the Slenderella table is there any positive upward and forward lift of the pads on the table?

A. No, there is no lifting.

Q. In the use of the defendant's table are any of the internal organs of the user lifted toward their normal position?

A. I suppose that if some of the abdominal con-

(Testimony of William I. Fishbein.)

tents were loose—and they usually of course are not, they are fixed except some sections of the bowel—as the table moves [280] toward the head it would shake them up there.

But the moment it moved back the other way it would shake them in the other direction equally as much, merely because by the force of gravity they would tend to stay where they are and until you put some force on them they wouldn't change position.

The Court: Aren't they pretty well anchored down, anyway?

The Witness: Yes, they are. It would be a sad thing if the internal organs were loose. Of course, the bowel isn't tightly fixed.

Q. (By Mr. Cox): In the use of the defendant's machine, Dr. Fishbein, is tension relieved in the supporting tissue for any of the internal organs?      A. I didn't hear that.

Q. In the use of the defendant's machine is the tension relieved in the supporting tissue for any of the internal organs?      A. Not at all.

Q. You understand that the reason some of these questions may appear rather complex is that I am following the language of the patentee in the specifications of the patent.      A. Yes.

Q. Is such supporting tissue rested and strengthened?      A. Not by any means. [281]

Q. In the use of the defendant's table are any of the internal organs gently lifted upwardly or towards the head of the patient, and then released?



(Testimony of William I. Fishbein.)

A. Not at all.

Q. In the use of the defendant's table are any of the user's internal organs constantly lifted toward their original position?

A. Well, since the organs rarely get out of their position, and since these tables are not used for the treatment of any abdominal condition, certainly, I would say the answer is no.

Q. Does the defendant's machine release tension upon strained tissue, giving nature an unrestricted opportunity to return any of the organs to normal position, and function?

A. I think it would have just the opposite effect.

Q. Would your answers to any of the foregoing questions about the use of the defendant's machine be any different if I had specified that as a condition of the use thereof the person using the same was lying on the machine in a position similar to that shown in Figure 1 of the Stauffer patent in suit, with his knees bent as shown there?

A. It would make no difference which way—

Q. You are familiar with that Figure 1 of the patent?

A. Yes, I am. It would make no difference in which position he would lie on the table. [282]

Q. I beg your pardon, Doctor?

A. I say, the position on the table would make no difference in the end effect with the table.

Q. Does the use of the Slenderella table relax any of the muscles of the spinal tract of the user?

A. No, our Slenderella table doesn't relax any-

(Testimony of William I. Fishbein.)

thing. It exercises, and exercise indicates a state of contraction rather than relaxation.

Q. In the use of the defendant's machine do such muscles of the spinal tract of the user become soft and pliant?

A. No, the effort on the part of the system is to make the muscles not soft and pliant, but to increase their tonicity and strength.

Q. From your study of the Slenderella table and in your opinion would the user of such a machine aid directly or indirectly the action of the heart of a user?

A. Of course, all exercise, no matter type, has the same effect. Exercise increases the rate of the heart beat, increases the rate of respiration and would speed up the rate of flow of the blood.

Now, for the normal heart and the normal individual those processes are going on every day. Your heart beats faster when you move around than when you are sitting quietly.

But for the individual with an abnormal heart these [283] increases in rate might be dangerous, and the Slenderella system would never be applied for anyone who had any circulatory difficulty, and particularly if there were a disturbance in heart function.

Q. Is the defendant's machine adapted to forcibly lift the body of the user in a direction toward his head, a distance of approximately two inches, and then return the body to the point of beginning?

(Testimony of William I. Fishbein.)

A. It doesn't lift at all, it merely moves the body back and forth or moves the muscle groups.

Q. In the use of defendant's machine, is there any relief of tension on the weakened tissue of the body?      A. Not at all.

Q. In the use of the Slenderella table, is a human body thereon moved in a greater degree, or the principal effect, in one direction of movement of the pad than in the other direction of the movement of the pad?

A. Movements are almost exactly the same in both directions.

Q. In a word, what would you characterize, Doctor, as the chief or principal physical or therapeutic characteristic of the Slenderella table, as you have observed it in operation?

A. Merely to give passive exercise. There is also some active component, since when any muscle is moved the [284] opposing muscle contracts in order to keep the movement from going too far. It is almost a reflex action. It is called the stretch reflex and depends on prolonged tendons. But by far the greatest effect is just passive exercise.

Q. As described by you, the Slenderella table has no apparent therapeutic or medical effect which you have observed?

A. It has never and would never be employed for any. Any therapeutic or medical effect should be carried out under the directions of a physician, and only under his directions.

Mr. Cox: You may cross examine.

(Testimony of William I. Fishbein.)

Cross Examination

Q. (By Mr. Lyon): Dr. Fishbein, what was the nature of the consulting work which you were employed to do for the Slenderella System of Stanford, Connecticut?

A. I was employed for a number of purposes. One was to prepare a series of diets for reducing purposes.

The second part of my employment was to educate the operators in the Slenderella salons, to give them some basic information relative to exercise and the effects that might be produced by the tables.

And then there are some matters connected with nutritive products.

Q. Do you have a proprietary interest in the defendant or any of the other Slenderella associated companies? [285]

A. Not at all.

Q. You are not a stockholder in any Slenderella Company?

A. Not at all.

Q. Do you obtain a regular retainer from any of the Slenderella organizations?

A. I obtain a retainer for services which I render to them.

Q. Were you here on the opening day of trial?

A. Yes.

Q. Did you see that motion picture?

A. Yes.

Q. Did you notice during the portrayal of the picture the X-ray shots?

A. I did.

Q. Do you disagree that the picture, by diagram and also by picture, indicated a flexing of the spine

(Testimony of William I. Fishbein.)

and opening up of the distance between the various vertebrae?

A. Well, since that motion picture went very rapidly I certainly would never base any scientific opinion of any kind on seeing it. In order for me——

Q. I didn't ask you that, Doctor. I asked you whether you disagreed with the picture when it makes that claim.

A. I refuse to comment on that picture because I couldn't tell what was happening. It went so rapidly that I [286] had no idea.

Q. Now, you recall a part of the picture was in diagram?      A. Yes.

Q. And that diagram purported to show an opening up and a closing of the distance between the vertebrae of the spine, as the treatment was given.

Do you agree or don't you agree that such an effect occurs when a patient is on a Slenderella table?

A. I would absolutely be unable to tell until I made the same type of observations on a patient who was on the Slenderella table.

Now, I might say that to stretch the spine and to bring about any noticeable variation in the interspaces between the vertebrae is practically an impossibility, without either fracturing something or injuring the disks.

The spine remains a fairly rigid structure. The inter-vertebral spaces only become altered when you



(Testimony of William I. Fishbein.)

take one of the disks and pull it out of place or it is ruptured or protrudes or herniates.

For the spine to separate to any degree, where you could notice it in an X-ray plate, it just doesn't occur in medicine.

Q. You mean that when a person bends over that—— A. There is merely—— [287]

Q. ——the spine does not open up on one side and close on the other?

A. No, there is merely a sliding of the intervertebral spaces, one over the other, and the change in contour is very slight.

You do have an alteration in the total structure, certainly, when you are in a bent position than when you are in an upright position, but the change is so slight that you can't see those things and certainly you don't see them in this movie and this X-ray.

Q. Did you observe in the movie a manipulation of the rib cage?

A. In the movie I saw some movement of that female body in various directions. I don't know what was producing them.

I certainly would never rely for any scientific evidence on a movie, because I have to see the thing myself before I draw any opinion.

Q. You did, however, notice a manipulation of the rib cage?

A. I noticed the rib cage moving. Now, whether the movement was due to the manipulation or

(Testimony of William I. Fishbein.)

whether she was taking a deep breath each time I couldn't tell that.

I could only tell it after I saw the patient or the person on the table. [288]

Q. Is it your opinion that the treatment of a patient who is suffering from a forward dip of the pelvis on a Slenderella table would not have any effect towards moving that pelvis back into its normal position?

A. Well, first, let me say that so far as I am aware in scientific medicine we don't have any term called "forward dip of the pelvis".

Now, it may be possible that the pelvis may tip anteriorly, but the effect would be produced primarily because of an original disturbance in the spinal column, and to manipulate the pelvis in order to force the spine back into position just wouldn't work out.

The vertebrae are in alignment, they are always in alignment unless we have some severe injury. We do get abnormal curvatures, particularly forward bending of the lower part of the spine.

But in order to correct that would require a great deal of voluntary effort. You could exercise for days and days and days, and unless the individual made a voluntary effort to stand up straight his spine wouldn't be pulled back in the normal position.

And in the same way, the pelvis is not going to be pulled back in the normal position without voluntary effort. Now, you could possibly strengthen

(Testimony of William I. Fishbein.)

muscles by table treatment, by passive exercise, so that once the structures were brought [289] into normal position it would be easier for the individual to keep them there.

But how extensive that is in the Slenderella table or any other table, or any system of passive exercise, of which there are thousands, I couldn't tell you because, as I said, we are just now engaged in making some measurements to see if passive exercise is really a factor in producing increased muscle strength.

Q. I believe you did agree, did you not, Doctor, that a patient taking a treatment upon a Slenderella table might have an increased rate of the flow of his blood?

A. Yes. But the same thing would happen if the patient merely walked down the street or took any kind of exercise; it wouldn't make any difference what type.

Q. Have you ever been in a gymnasium, such as Vic Tanny Gymnasium?

A. I have never been in a Vic Tanny. I think I maybe, in my younger days, have gone to the Y.M.C.A. I have been in school gymnasiums.

Q. As a doctor, have you ever prescribed that a person should attempt to create a better condition in his body by working out in a gymnasium?

A. No, no, that would be the last place I would send them, because people are bored with gymnasiums and they won't go and they won't stick to it. [290]

(Testimony of William I. Fishbein.)

Q. As a doctor, have you ever prescribed that a person should hang by their hands from an overhead bar?

A. No. If you are trying to produce an effect on the spine, that would not be the way you would do it.

In order to produce an effect and make it be permanent or helpful, you would have to put them in traction, which means that you would have to suspend them by their neck and maintain variation on that for varying periods.

That is often done by the orthopedist, in order to relieve the so-called strictures of the spinal nerves.

Q. Well now, with a person lying flat on a Slenderella table, and in the first position in which the applicators or pads are beneath the buttock of the patient, and were in the cycle wherein all the motion is in unison on the forward motion, that is, toward the head of the applicators, there is a stretching of some of the muscles, is there not?

A. I don't think that you would stretch any muscles. What you would do is merely shake them, and if you had any resistive elements in this it would be a contraction of the muscles, not a stretching.

The only way you can stretch a muscle is to pull it beyond its capacity during the relaxing phase. The muscle when relaxed is the longest. When the muscle is contracted completely it is the shortest; it gets short and thick.

(Testimony of William I. Fishbein.)

Now, you say "stretch the muscle". That [291] would imply pulling it either from its origin or from its insertion. And you couldn't stretch it unless you were able to get hold of the tendon and do that to it.

Q. Now, when a person is on a table in the position I indicated, the major portion of his body is on the stationary part of the couch, is it not?

A. Yes.

Q. Does that not serve as an anchor against which——

A. No.

Q. ——we pull when we elevate the part that is being shaken?

A. No, it doesn't act as an anchor because the body moves back and forth. If you will even look in your own motion picture you will see that the body is not firmly fixed even to your own table. That is only an opinion of what I could see of that picture, and it wasn't too clear.

But on the Slenderella table, the body certainly is not anchored at either end.

Q. The Slenderella System, do they ever use sandbags?      A. Not that I know of.

Mr. Lyon: That is all.

Mr. Cox: No redirect.

Mr. Harris: The court please, may the witness be excused.

The Court: Yes, this witness is excused.

(Witness excused.) [292]

Mr. Harris: At this time, if the court please, on



behalf of the defendant I move to strike the motion picture which is Plaintiff's Exhibit 3, on the ground that there has been no foundation laid, it is irrelevant, it is immaterial, and it is, so far as the masthead is concerned and so far as the sound track is concerned, entirely hearsay so far as these defendants are concerned.

The Court: The motion is denied, but in denying it the court recognizes that the masthead and the commentary are hearsay.

But still it is orienting matter, much as much of the colloquy and statements of counsel have been, so I think it is harmless. And the picture itself, as a depiction, I think, may be evidence; certainly evidence which you have undertaken to rebut.

Mr. Harris: May I renew my motion limited to striking the masthead of the picture and the sound?

The Court: Any opposition to that?

Mr. Lyon: Well, I think, your Honor, that—I am perfectly willing to have the masthead stricken and I am willing to have the sound track treated merely as an explanation of what is going on as our opinion, the same as an argument of counsel.

The Court: Well, that is the way I have indicated I am going to treat it. [293]

Mr. Lyon: I think it should stay in for that purpose.

Mr. Harris: If we treat the sound track simply as argument of counsel that is, of course, all right. I wouldn't want to have it as evidence in the case.

The Court: The court does not consider it as

evidence. I consider what one can visually see from a view of the picture as evidence.

But the sound track and the masthead are somewhat in the nature of argument.

Mr. Harris: As your Honor probably recalls, on the masthead, for example, it has the names of two gentlemen and their qualifications underneath, which might be prejudicial somehow in the case. That is why I want to strike that masthead, particularly.

Mr. Lyon: That can go out.

The Court: If a judge would be prejudiced by that, that prejudice wouldn't be removed by an order striking it once it has been viewed.

Mr. Harris: Excuse me. Did your Honor rule on my last motion to strike the masthead?

Mr. Lyon: That can go out.

The Court: The masthead goes out. The rest stays in.

Mr. Cox: At your Honor's pleasure, I do have three or four pages of Mr. Stauffer's deposition I would like to read into the record; at a time convenient to the court. [294]

The Court: I want to give you a full working day, but not too much of it.

Now, you have been getting fairly short days because of the pressure of other cases. I don't know how much longer the presentation of your case will require.

Mr. Cox: I think this is the conclusion of it, your Honor, and it shouldn't take over ten minutes to read these excerpts.

The Court: You may proceed now or, if you want to, you can have as much of the day Monday, after a short law and motion calendar, as you desire.

Mr. Lyon: Let's go over to Monday.

Mr. Cox: I am entirely at the pleasure of the court and counsel.

The Court: I should complete the law and motion calendar on Monday by 10:30. Suppose we say 11:00 o'clock?

Mr. Cox: All right. Fine.

The Court: That will give us ample time. We will recess until 11:00 o'clock Monday.

Mr. Lyon: Might I make an inquiry, your Honor?

The Court: Yes.

Mr. Lyon: From a statement you made to the Doctor this morning, it would indicate you intend to have this case submitted on briefs.

The Court: I thought you were going to ask for that. [295]

Mr. Lyon: All I want to know is whether I should be prepared to argue this case Monday afternoon or not. It means a little different work schedule over the week end.

Mr. Harris: I suggest we argue on Monday afternoon and the case be submitted on that argument, or your Honor decide it from the bench, as your Honor sees fit.

The Court: That is the way we like to do these things, because the pertinent art is fresh in our minds if we have the argument currently here.

But it seems to me the style in patent practice is to have a transcript written up and then to brief it and prolong the matter for some six months, by which time the judge has forgotten all about it and has to do a lot of reading.

I will accommodate myself to that procedure if you wish to follow it. It is the standard prevailing practice here.

If you want to argue the case Monday, I will probably decide it Monday, or if not decide it Monday, decide it within a few days thereafter.

Mr. Harris: I suggest the latter procedure, because this is a simple case so far as the issues are concerned.

In a complicated patent case, we would ask to write briefs, but I wouldn't want to in this case.

The Court: The case appears to be a simple one, so far as the court is concerned. You might not get a decision Monday, but I would say that unless some impediment of [296] health arises you will get one before the end of the week.

Mr. Harris: We would like that very much.

Mr. Lyon: I will be prepared to argue Monday afternoon.

The Court: Thank you. Adjourned.

(Whereupon, at 4:12 o'clock p.m., Friday, November 16, 1956, an adjournment was taken to Monday, November 19, 1956, at 11:00 o'clock a.m.) [297]

Monday, November 19, 1956. 11:03 A.M.

The Court: As stated at the close of the session

last week, you can have all day today if you wish. However, we are going to have to adjourn shortly after 12:00 because the judges have some problems they are going to discuss at lunch today and I will have to go to that.

Either finish by 12:00 or we will reconvene at 1:30. I don't mean to rush you. I would just as soon listen to you all afternoon.

Mr. Cox: As stated on Friday afternoon, your Honor, we have about four pages of Mr. Stauffer's deposition I would like to read in the record.

The Court: Yes.

Mr. Cox: I might state that the original deposition is on file with the clerk and I have been advised no corrections were made in the deposition. Is that correct, Mr. Lyon?

Mr. Lyon: Yes.

Mr. Cox: It was filed without correction.

The Clerk: The deposition has not been filed, your Honor.

The Court: I am sorry, I didn't hear you, Mr. Cox.

Mr. Cox: I stated, your Honor, it is my understanding the original deposition had been filed without corrections having been made by the deponent, and Mr. Lyon tells me that [301] is the fact.

The Court: Of course, we don't know unless we compare with whatever copy the deponent made his corrections upon.

Mr. Lyon: There were no corrections.

The Court: Do you mean he didn't want to make any or that they just didn't get made?



Mr. Lyon: We didn't find any we felt it was necessary to make.

I handed this original to the clerk the opening day of trial and asked him to file it. I see he hasn't stamped it filed.

The Court: That is the deposition of Mr. Stauffer, who is present?

Mr. Lyon: Yes.

The Court: Mr. Stauffer, did you look it over?

Mr. Stauffer: I read most of it, your Honor, yes.

The Court: Any corrections you want to make in it?

Mr. Stauffer: No.

The Court: That is your privilege, although Mr. Lyon's privilege and his duty to go over it and bring things to your attention which he might think are incorrect.

You are the witness, so it is up to you whether you feel there is anything that needs to be corrected. If there is, it can be corrected, but we can't take the time right now to have you go over it all. [302]

Mr. Lyon: Mr. Stauffer has been over it, sir, and has signed it.

The Court: All right. It may be filed.

But if, as it is being read, Mr. Stauffer, you note the reporter who took it down misunderstood you and didn't report it correctly, just make a little note of it and give it to Mr. Lyon and immediately after it has been read we will have it corrected.

Mr. Stauffer: Thank you.

Mr. Cox: I will commence reading at page 54. line 1:

“Q. (By Mr. Cox): Do you recognize Defendant’s Exhibit C for identification as the franchise agreement that you granted on or about August 1, 1946 to the parties therein named?”

“A. I would say that was it, yes.

“Q. Was that the standard printed form of the franchise agreement generally in effect between Stauffer System and the licensees at that time?”

Mr. Lyon: If the court please, I think this is an appropriate time for me to state my objection.

As we have pointed out before in the trial of this case, as is evident from Plaintiff’s Exhibit 15, I believe it is,—that is correct—on January 25, 1953, there was executed between the parties to this lawsuit mutual releases.

The Court: Those releases released down to the [303] day of their signature, didn’t they, but they did not release into the future?

Mr. Lyon: That is correct, your Honor. But I wish to point out that Mr. Cox’s question relates to August 1, 1946.

So let us assume that that document that he is referring to in 1946 was illegal, and it, by some odd chance, had some effect against the Slenderella Systems or Mr. Mack, or any of the Slenderella companies, still its effect is totally wiped out by that release of January 1953.

The plaintiff’s position in this case is that anything that occurred prior to January 25, 1953, is wholly immaterial.

The Court: What is the materiality of it, counsel?

Mr. Cox: Very briefly, this, your Honor: The two excerpts from the deposition I propose to read illustrate that during the period of time, certainly from 1946 through 1950 or 1951, the patentee in this action issued franchise or license agreements, which contained both price-fixing provisions and tie-in agreements.

It is our position those constitute misuse of his patent. While I agree with Mr. Lyon, a release in some form was presumably given by the defendant to the plaintiff—in, I think it was, September 1953, Mr. Lyon,—our position very briefly is that we as defendant in this action cannot exonerate or excuse misuse of the patent on the part of the patentee for the simple reason it involves a question of public policy. [304]

A simple release given by the defendant in this case to the plaintiff would not exonerate or excuse if, in fact, there had been misuse of the patent.

Whether or not that misuse continued up to the date of trial, I don't know. I think it will be up to Mr. Lyon to demonstrate it did or didn't.

Mr. Lyon: I think it will not be disputed, I don't believe, that in 1950 and '51 the Stauffer franchising system was revamped, and that since that date there has been no existing franchise agreement that either had price-fixing clauses in it or tie-in clauses.

The Court: If that is so, I suppose you should show it by evidence. What Mr. Cox is apparently doing is undertaking to show a situation which prevailed prior to January 25, 1953, and then bring

into play the presumption that what was once established is presumed to continue.

Mr. Cox: That is correct, your Honor.

The Court: And that is a form of evidence, standing by itself in this present commercial competitive world, that is not awfully strong, but it is a presumption which must be weighed along with the other evidence.

And I think, so far as admissibility is concerned, this evidence is admissible. And it might—I haven't heard it yet—it might bring into play that presumption, that it [305] might be inadequate to do so. We will have to hear it and see if it does bring the presumption into play. Or if there is any feeling on your part that it might do so, Mr. Lyon, we will hear your evidence in rebuttal.

Mr. Cox: Continuing to read from the deposition at page 54, commencing now with line 6:

“Q. Was that the standard printed form of the franchise agreement generally in effect between Stauffer System and the licensees at that time?”

“A. Yes, it was.

“Q. I call your attention to Paragraph 8 of Exhibit C for identification, which reads: ‘The Licensor will furnish the Licensee with a written schedule of prices to be charged customers for the Stauffer System treatments, and the Licensee agrees at all times to maintain the said written price schedule as furnished by the Licensor.’ Did you have in effect at that time schedules of prices to be charged customers for Stauffer System treatments?”

“A. We had suggested prices but we have never enforced any of them.

“Q. Were these schedules of prices furnished to your franchise holders by you?

“A. I don’t think they were ever furnished, other than in terms of schedules. They were [306] suggested. I think some of the covers bore the price,——”

Mr. Lyon: “\* \* \* some of our covers”.

Mr. Cox: (Continuing reading:)

“I think some of our covers bore the price, but to my knowledge I don’t think we ever had specific schedules of prices.

“Q. Did you ever have any written schedule of prices?

“A. It is possible that we had suggested schedules, yes.

“Q. Were those written schedules delivered or communicated to the franchise holders?

“A. Well, I would say both.

“Q. Do you have those schedules or exemplars of those schedules still in your possession?

“A. It is possible we could pick some up.

“Q. If you find that you have them in your possession, are you prepared to furnish them to us for inspection?      “A. That is right.

“Q. Do you recall when you first initiated this program of written schedules of prices?

“A. I think it was 1946.

“Q. You think that is when the practice started?

“A. Yes. [307]

“Q. For how long did that remain in effect?



“A. Oh, about 1950-1951.

“Q. Did those price schedules change during that period of time?

“A. I think they were originally one dollar and they were suggested to two dollars.

“Q. Per treatment?

“A. Per treatment in series.

“Q. Did the price schedules also contain suggested retail prices for the Staufferettes?

“A. We had a retail price on them. However, some of those salons gave them away; some of them charged. There was no standard price.

“Q. The price of Staufferettes was not included in your price schedule, as I understand you?

“A. I don't think so, no.

“Q. Would it be correct to say that according to your present best recollection your price schedule covered only the suggested price of treatments to customers?

“A. My recollection is that that is correct.

“Q. Did these schedules deal with matters other than the cost of this treatment; did they suggest the price for designated courses of treatment?

“A. Yes, I think that the multiple treatments [308] were \$2 and the single treatment was \$3.

“Q. Did the suggested price, for example, of a course of say eighty treatments go out to franchise holders?

“A. I don't think so. I think we only had this one price, \$2 a series and \$3 for individual treatments.”

Resuming the deposition at page 58, line 4:

“Q. Well, when you stated a few moments ago that in about 1951 you ceased the practice of suggesting prices to the franchise holders, do I understand from that, that the prices scheduled in your manual were deleted in 1951?”

“A. No, we still had a suggested price schedule but we didn’t have any implication in our franchise as to the cost.

“Q. I see, so that in 1951 you changed the form of the franchise to eliminate the requirement that the licensee maintain and adhere to your original price schedule?      “A. That is right.”

I will now read from page 13, commencing at line 14:

“Q. And did the Stauffer System, in addition to the tables and the suggested diet, also conduct the sale or dispensation of vitamins in any form?”

“A. We have a form of Vitamineral food supplement that was available in areas where it was legal to sell it. That was not necessarily mandatory; it was, you might say, a supporting factor for those salons who could successfully use it.

“Q. I think you called that ‘Vitamineral food supplement’?”

“A. No, I think we called it ‘Staufferettes.’”

“Q. Are those Staufferettes manufactured by this partnership we have been referring to?”

“A. We have it manufactured by a registered laboratory.

“Q. What laboratory; just one laboratory?”

“A. S. O. Barnes.

“Q. Are these Staufferettes supplied free of

charge to the franchise holders or do they buy them from you?

“A. They buy them and they sell them.

“Q. They, in turn, sell them to their customers?

“A. That is right.

“Q. Do these Staufferettes include, in addition to vitamins and minerals a bulking compound?

“A. Staufferettes do not, no.

“Q. Do you have any bulking compound which you furnish? [310]

“A. We have an appetite appeaser, called ‘Skimps.’ That has that bulking compound which you refer to.

“Q. How do you spell Skimps?

“A. S-k-i-m-p-s.

“Q. Does the partnership manufacture these Skimps?

“A. They are manufactured by the same laboratory.

“Q. S. O. Barnes? “A. That is right.”

I am terminating the reading at line 20, page 14. Recommencing at page 61, line 7:

“Q. Let me call your attention, Mr. Stauffer, to Paragraph 12 of Defendant’s Exhibit C for identification, which is now in front of you, which is a form of franchise agreement which you had in 1946. That paragraph reads: ‘As a part consideration in granting the Licensee this exclusive franchise, the Licensee agrees to use Stauffer Tables and Stauffer Equipment and Products exclusively, and to purchase, rent, or obtain same solely through the Licensor. Licensee agrees not to sell or deal in

any product or products, or permit the use of any products within any salon established under the terms of this agreement, except such as are [311] manufactured or endorsed by the Licensor.'

"Did Stauffer System, the partnership or the corporation, manufacture any products other than Staufferettes and Skimps and the tables?"

"A. We manufactured a lamp and some of the salons had them and some of them didn't. Other than the tables and the Staufferettes, there wasn't anything else manufactured."

I terminated the reading at page 61, line 24.

Continuing on page 63, line 4:

"Mr. Cox: Q. During this period when this form of agreement was in effect as contained in Paragraph 12, were any Stauffer salons using any of these vitamins, minerals or appetite appeasers other than the Staufferettes or Skimps?"

"A. Not to my knowledge."

That terminates the reading at page 63, line 9.

That is all we propose to read out of the deposition, your Honor.

Mr. Lyon: I think on page 58, just succeeding the part that Mr. Cox read on that page, Mr. Cox asked Mr. Stauffer:

"Q. What was the occasion for your discontinuing that requirement in your franchise agreements in 1951?"

"A. Well, we employed an attorney to draw a new franchise and that was one of the things that we dropped out." [312]

That is all I care to read from the Stauffer deposition.

Mr. Cox: May I ask the clerk to pass me Exhibits 12 and 13 for identification?

Mr. Lyon, referring to Exhibits 12 and 13 for identification, these were furnished by you in the early stages of the trial, pursuant to a subpoena duces tecum served on Mr. Stauffer, were they not?

Mr. Lyon: Yes.

Mr. Cox: May it be stipulated, Mr. Lyon, that Exhibits 12 and 13, respectively, were at one time furnished by Mr. Stauffer to his franchise holders?

Mr. Lyon: Yes.

Mr. Cox: I would like to offer Exhibits 12 and 13 into evidence, if the court please.

Mr. Lyon: I don't see any materiality to Exhibit 13.

The Court: Well, if it is immaterial, I will have to determine that, first, I suppose as a condition to rejecting it, or find an absence of immateriality or presence of materiality to get it in. Otherwise, I will weigh it in submission.

Suppose you hand it to the clerk and I will determine now whether to admit it.

Mr. Cox: I call the court's attention to the last four or five lines on the second page of Exhibit 13, [313] with particular reference to suggested retail sales prices in that exhibit.

Mr. Lyon: It is a question of materiality.

The Court: Are you contending you are right to maintain the first and second counterclaims under the Sherman Act or the Clayton Act?



Mr. Cox: Under Section 4 of the Clayton Act, your Honor.

The Court: Thank you.

Mr. Harris: That is only as to the second counterclaim, your Honor.

The first counterclaim is only for declaratory judgment as to the validity of the infringement to the patent in suit.

The Court: Yes. I thought there was an anti-trust feature in this first counterclaim.

Mr. Harris: No, we are pleading in the defense, as an affirmative defense to the patent action we are pleading patent misuse, and in effect that is in our Answer and——

The Court: Then if that is in the Answer, then you get into the counterclaim and ask for declaratory relief.

Mr. Harris: That is correct, your Honor. The first counterclaim, for declaratory relief, as to validity and infringement of the patent in suit.

In the second counterclaim, it is a counterclaim for damages under Section 4 of the Clayton Act.

The Court: Exhibits 12 and 13 are pertinent [314] evidence as to the counterclaim. They are material evidence as to the counterclaim, and they are received into evidence.

(The documents heretofore marked Plaintiff's Exhibits 12 and 13 were received in evidence.)

Mr. Cox: We have just one other problem, your Honor, in connection with the second counterclaim, and that is the establishment of damages.

Relying on the Kobe case, which is referred to in our pretrial memorandum, the court will remember that particular case, or remember the facts of that case. The damages were found in part to be the cost and expenses and attorney fees of defending the patent infringement action.

We have not adduced any evidence as to our costs of defending this action or our attorney fees.

We would like, with the court's permission, to defer as to damages until the court has ruled upon whether or not there is, in fact, a violation of the antitrust laws.

The Court: You want me to adjudicate the case piecemeal then?

Mr. Cox: No, your Honor. If your Honor finds in favor of the defendant, there will have to be an accounting for damages.

It would seem appropriate at that time, if your Honor should find for the defendant, in connection with the antitrust phase of the action, we will [315] adduce evidence of our expenses of defending the suit.

Mr. Lyon: The court please, I will offer in evidence the defendant's Answers to plaintiff's Interrogatories, in which we asked them what—

The Court: Let's see, have you rested?

Mr. Cox: Subject to the court's ruling on my request for leave to adduce evidence as to the damages at a subsequent date.

The Court: If you get your attorney fees in a patent action, they are handed out by the court, that is, the decision is handed out by the court

upon a showing of some unconscionable situation. They don't follow automatically, even if there has been a violation of the Clayton Act.

They are adjudicated because one party to the litigation has maintained an unconscionable attitude, such as would shock the chancellor's conscience, so he says, "Well, they get attorney fees," one which would intimate they maintained that, but who suffered by it get attorney fees.

As to that, the court looks to the patent law. I don't think there is anything in either the Sherman or Clayton Acts about attorney fees in the attorney fees section.

Of course, you can get attorney fees in a treble damage suit. But in using either of those Acts as a basis for counterclaims here, which is, as you are urging it, primarily an affirmative defense. [316] You are claiming that the patent was misused for the purpose of destroying competition in interstate commerce, and therefore the law will not lend itself to the upholding of the patent even if it otherwise be good.

Isn't that what you are doing?

Mr. Cox: And, your Honor, the law would go even further. As is illustrated in the Kobe Pump case, the law will also permit the defendant filing a cross-complaint for violation of the antitrust laws—if the court finds there has been such a violation, will allow the defendant damages, which damages are measured by the cost of having to defend an unfounded action for infringement of the patent.

Mr. Lyon: May I be heard on that, your Honor?

The Court: Yes, but let me ask Mr. Cox another question.

Is an attempt to violate the Clayton Act sufficient? That is, do they have to actually go so far as to have a restraining effect upon the interstate commerce?

Mr. Cox: I think there rather has to be a restraint on interstate commerce or there has to be a monopoly or an attempt to monopolize.

The Court: You are not conceding that Stauffer has a monopoly over the Slenderella, are you?

Mr. Cox: I am claiming, from the evidence, that prior to the advent of Slenderella in 1954 he [317] constituted essentially the only one in the field and that he did have a monopoly, and it is our position——

The Court: Slenderella got into the field and has prospered in the field, or at least has been active in it. Maybe the price competition was such they couldn't prosper, but they are able to put pretty ambitious television advertising on and they seem to be quite active. You see Slenderella advertised all over and it has a Good Housekeeping seal.

When they did get into the field there certainly was competition. How did the trust hurt you?

Mr. Cox: There is no question about the existence of the competition. Our position is simply Mr. Stauffer, by this very action, is attempting to promote that competition by eliminating Slenderella as a competitor of Stauffer.

The Court: Slenderella is a trade name.

Mr. Cox: That is correct.



The Court: He is objecting here to Slenderella using any of those other structures.

Slenderella could go out and get some Miller devices constructed and put them in its salon, so far as Mr. Stauffer or the Stauffer Systems are concerned, and continue to operate under the name Slenderella.

All he wants the court to do is to restrain the further infringement of a patent and to give him damages for the past infringement. [318]

Mr. Cox: That, I think, is correct.

The Court: How did the trust hurt you? You got going pretty well in spite of it.

Are you saying you are hurt because you had to come in and defend this patent infringement suit?

Mr. Cox: I think if the action were initiated without good cause and without any proper foundation, really believing it, on the part of Mr. Stauffer, that there had been an infringement, I think we are hurt to the extent of our expenses of defending the action.

The Court: Then the court will be required to make a finding as to whether or not Mr. Stauffer is acting with probable cause, shall we say. If it is good cause we don't hold his patent for sure.

But if he has probable cause to believe he has a valid patent and he is not infringing the Clayton Act at the time of the infringement of the patent, can't he come in here even if at one time he did have antitrust violations existing from both ends?

Mr. Cox: I think there is no question but the



courts are open and available to Mr. Stauffer, or any other patentee, for purported infringement.

I believe, on the other hand, Mr. Stauffer is in substantially the same position as was the plaintiff in the Kobe Pump case, where the court found the [319] plaintiff there initiated the patent infringement action without any knowledge or understanding of the alleged infringing machine, the alleged infringing pump.

The Court used that as evidence, in part, at least, of bad faith in bringing the particular patent infringement action.

The Court: Well, we had a case here, one of Mr. Lyon's cases, in which a vacuum cleaner company stole a patent of one of its salesmen, or, *sold* the invention and patented it, and we found that was unconscionable and allowed fees, didn't we, Mr. Lyon?

Mr. Lyon: Yes, sir, as part of the patent infringement action.

Your Honor please, the defendant's theory here is drawn from the Kobe case. In the Kobe case there was an action for patent infringement and a counterclaim for violation of the antitrust laws.

The court found that right from the very beginning there was a conspiracy and combination in restraint of trade. There was a pooling of patents and a monopoly, and that the patent infringement action was brought as part of the conspiracy in restraint of trade.

As such, as one additional element of damage to

the counter-defendant, they allowed his costs of suit.

I think the case stands unique in the law. [320] It is contrary to a case of—controlling, or, at least, one controlling Supreme Court decision. It has never been followed. It is contrary to *Straus v. Victor Talking Machine Company*, 297 Fed. 791, wherein the court said:

“We base our ruling on a stronger ground. The courts must not be closed, litigants must be free to press their claims even though they may lose them.”

And to penalize a patentee for bringing suit by making the costs of suit the damages of an anti-trust action would effectively close the courts to patentees.

Another case, *International Visible Systems Corporation v. Remington-Rand, Inc.*, 65 Fed. (2d) 540, the Sixth Circuit refused any such idea and, of course, as I said, the Supreme Court certainly ruled out any such idea in *Virtue v. Creamery Package Manufacturing Company*, 227 U.S. 8.

To bring it a little closer to home, just last April we tried a case before Judge Carter. It was a patent infringement case, a defense of misuse of the patents and a counterclaim for damages.

The counterclaim for damages was again, like it is here, based entirely on an attempt by the defendants to collect their costs and attorney fees of defending the case.

Judge Carter ordered the counterclaim dismissed for failure of proof of damage. He ruled that the type of thing they were trying to collect here,

[321] assuming they have any right to collect, is not an element of damage in an antitrust case.

That case has not yet been reported because the defendants have been a little bit dilatory in getting in their findings of fact and conclusions of law and suggested judgment.

But it is *Telon, Inc. v. Union Slide Fastener*. It is pending at the present time in this court.

The Court: You are not suggesting that I just get Judge Carter's oral comments about it when I go to lunch today with him?

Mr. Lyon: Well, I don't know how you judges operate.

The Court: We don't operate that way generally. Attorneys seem to think we do and they suggest something that happened in another court, without bringing us a transcript or a copy of the memorandum if it was done by written memorandum.

Of course, in this patent matter, patents are a monopoly, in the first instance. I think the Constitution says that the Congress may enact laws granting monopolies to inventors by issuance of letters patent.

Mr. Lyon: The Congress is empowered to promote the usual arts and sciences by rewarding authors and inventors with a limited monopoly in their inventions, discoveries and writings. That is what we have here. [322]

Have you rested?

Mr. Cox: Could we obtain a ruling from the court on deferring evidence of our attorney fees and expenses of litigation?

The Court: Yes.

Mr. Cox: Thank you. The defendant rests.

The Court: You would have to, in order to maintain successfully an action for relief, under the Clayton Act or the Sherman Act, you would have to show you have been damaged—I don't mean you, the attorneys, but you Slenderella—by the conspirators to maintain the trust, wouldn't you?

We don't issue a punitive damage. The right to generally redress, that is, the public's right to redress the maintenance of a trust is something which is enforced by the Attorney General, is it not?

The private litigant doesn't come in and get a bonus just because he is in the same business as the conspirators in the trust situation.

He comes in and gets damages for his actual out-of-pocket, or for the people who didn't come into his establishment, his actual damage proved upon the basis of any tort damage, where the tort relates to diversion of business.

And then sort of as a penalty we treble those damages. But it arises from damage in the business, not the damage which a person suffers to his purse by having had to defend a lawsuit. [323]

So we will defer the proof of the attorney's fees and the costs of maintaining this action until the court finds that you are entitled to some.

If you are entitled to some, we might hear it on a motion calendar day or it might be referred to a master.

However, in order to maintain upon the counterclaim it would be necessary to show that there was



some damage suffered to the business of Slenderella.

Mr. Cox: I think, your Honor, at this time it probably would be most appropriate for the defendant to withdraw the second counterclaim, without waiving their right to rely upon the patentee's misuse of the patent in suit.

The Court: You withdraw the second counterclaim?

Mr. Cox: Yes.

Mr. Lyon: I accept it.

The Court: You accept it or except to it?

Mr. Lyon: I a-c-c-e-p-t.

The Court: All right. Unless you had more evidence you weren't going to win on it, anyway, Mr. Cox.

Mr. Cox: I felt fairly sure of that, your Honor.

Mr. Lyon: I was going to offer at this time the Answers to the Interrogatories in which I asked them how they were damaged, and they answered, "Defendant claims no damage."

But in view of the withdrawal of the [324] counterclaim, I will skip that.

Will you resume the stand, Mr. Stauffer.

#### BERNARD H. STAUFFER

the plaintiff herein, recalled as a witness in his own behalf, having been previously duly sworn, was examined and testified further as follows:

#### Direct Examination

Q. (By Mr. Lyon): Do you have before you copies of Defendant's Exhibits D-1, -2 and -3, the



(Testimony of Bernard H. Stauffer.)

same being the patents to Miller, Parker and Gunderman?      A. I have, yes, sir.

Q. Turning our attention first to the patent to Miller; and an enlargement of the same is handy here, do you find in the Miller patent a device which could be used for giving a Stauffer treatment to a patient?

Mr. Harris: The court please, that is objected to on the ground there is no foundation laid. It is objected to on the ground Mr. Stauffer is neither an engineer, a doctor, nor has he been shown to have any knowledge of patents.

Mr. Lyon: Well, I better lay a foundation.

Q. (By Mr. Lyon): Mr. Stauffer, have you made a careful and detailed study of the Miller patent,—      A. Yes, I have.

Q. —No. 1,953,424? [325]

A. Yes, I have.

Q. And particularly the particular view, to compare it to the structure of your own patent in suit, No. 2,240,679?      A. Yes, I have.

Q. And have you made a similar study, with a similar view in mind, of the Parker patent, No. 1,978,223, Defendant's Exhibit D-1?

A. Yes, I have.

Q. And have you made a similar study of the Gunderman patent, No. 1,825,588, Exhibit D-3?

A. Yes, I have.

Q. This patent that we have in suit, No. 2,240,-

(Testimony of Bernard H. Stauffer.)

679, is that the only patent you have, Mr. Stauffer? I mean, that has been taken out in your name.

A. No, it is not.

Q. It is one of a series?

A. That is right, yes, sir.

Q. Do you have Canadian patents?

A. Yes.

Q. Do you have British patents?

A. Yes, I have.

Q. Since August of 1938, when you filed the application for your present patent in suit, what has been your experience with respect to the studying and reading and evaluating of the patents in [326] general, particularly in the therapeutic apparatus field?

A. Well, we have had a constant experience with millions of people coming through our salons in relation to the patents that we have.

We have naturally extended our investigation into other motions, as it is related to the possible use in the Stauffer System.

Q. During this period of time, have you had occasion to study a number of patents?

A. Yes, we are constantly studying patents in our business.

Q. Who in the Stauffer System has held the primary responsibility with respect to the patent policy of the company?

A. Well, I have held that position.

Q. All right. Now, calling your attention to the

(Testimony of Bernard H. Stauffer.)

Miller patent, No. 1,953,424, I ask you again whether there is any mechanism disclosed in that patent which could be used to give a Stauffer System treatment to a patient.

Mr. Harris: The court please, the same objection on the same ground.

The Court: Overruled.

The Witness: You want me to explain the action of the Miller table in relation to the action of the Home Plan—or the—— [327]

Q. (By Mr. Lyon): We will do that next.

Could you use the Miller table to give a person a Stauffer treatment?

A. Not a Stauffer treatment, no.

Q. Now, will you explain what the Miller patent does show?

A. The Miller patent primarily, in comparing it with the action of our No. 1 table, has a motion coming up against the body as it is strapped onto the platform or the couch. And the possibility of any motion back and forth in relation to the couch is automatically absorbed in this—(indicating)——

Q. Indicating the pivot point 32?

A. Pivot point 32. As this thing comes up, if it could come this way (indicating), it automatically must compensate by the absorption of the motion in this pivot point 32 (indicating), so you have eliminated—you have only an upward thrust and not the back and forth motion that is absolutely

(Testimony of Bernard H. Stauffer.)

essential to get the required results that the Stauffer table gets.

Mr. Harris: May I have my objection, the court please, to any and all testimony by Mr. Stauffer as to these three prior art patents, and any comparison of those patents with the issues in this case? I don't want to keep restating the objection.

The Court: I understand that you contend he is not qualified and I shouldn't be listening to him.

Mr. Harris: Yes, your Honor.

The Court: The court holds he is qualified and overrules the objection to the line of testimony.

Q. (By Mr. Lyon): Do you find in the Miller patent itself—and I mean in that printed specification—any description of the motion of the pad 27?

A. The back pad 27 is adjusted longitudinally by sliding it up or down at the hinged arm 33, and the vertical adjustment is made by means of the slotted link 44, and produces an upward pressing against the spine.

On line 25, page 3, it says:

“The chest and the back pads 28 and 27 respectively operate in unison, that is, as the chest straps are pulled downwardly to contact the chest, the back pad 27 simultaneously presses upwardly against the spine.”

Q. Now, with that particular description in mind, would you say that the Miller patent has an applicator which oscillates axially of the length of the couch?

A. It definitely does not operate axially, no.

(Testimony of Bernard H. Stauffer.)

Q. As a matter of fact, this Miller patent is a sort of an artificial respiration system, isn't it? The straps across the chest and the abdomen are pulling down, while the applicator is pushing up, is that correct? [329]

A. It would induce that type of effect to the lung area.

Q. Now, turning your attention to Exhibit D-3—

The Court: Before you get to that, what do you mean by oscillatable?

The Witness: Oscillatable in my determination is back and forth, longitudinally, with the top of the table. In other words, this motion (indicating), by virtue of the mechanism, as it is applied to this point, is forced to push upward and there is a slight possibility of it moving longitudinally, but it is absorbed by this thing here (indicating), which, when the weight comes down on that, there cannot be any motion here (indicating), because this thing is capable of being hinged this way and continues upward, rather than back and forth (indicating). There is no back and forth motion here whatsoever (indicating). This absorbs all that motion (indicating), when you put that hinge in there and this action forces it right straight up against the straps, and that is what you have (indicating). You have a motion here that is going right straight up and not back and forth with a tilting action, like our patent does (indicating).

In other words, the motion is not capable of giv-



(Testimony of Bernard H. Stauffer.)

ing a Stauffer treatment that gives postural alignment and gives an entirely different motion to the body. It is in a sense a wave motion—or, rather, a pushing motion, rather than a [330] wave motion that is applied to the body.

The Court: Your machine has the wave motion?

The Witness: Ours induces the wave motion because of its single action, yes, sir.

Q. (By Mr. Lyon): Will you turn your attention now to the Gunderman patent, No. 1,825,588, Defendant's Exhibit D-3?

A. (Witness complies.)

Q. In the first place, it is quite obvious, is it not, that this device does not contain a couch (indicating)?

A. No, it does not.

Q. Is a couch an important part of your device, your patent?

A. It is very important because it allows that part of the body that is not on the movable platform to act as an anchor, in which the motion of the platform stretches the muscular tissue between the anchored part and the movable part, thus giving traction (indicating).

Q. Do you care to draw a distinction between what you just described for the judge, that is, oscillation and vibration?

A. I have had that discussion for quite a while, and we have done our best to identify it. We have done some work with U.C.L.A. in that respect. To the best of our knowledge, we terminate—or, rather, we identify vibration as motion that is fast enough

(Testimony of Bernard H. Stauffer.)

to induce a counter-restriction against or a [331] tension of the vibration.

But when the motion becomes below the moment of that tension—not to induce any striction—constriction in the nervous system or in the muscular areas, then it is considered oscillation.

The Court: Do you have to have a subject to which the device is applied in order to get vibration?

I have always understood vibration can exist in a device itself. From this answer, it would seem that you have to have a nervous system for it to work on or a muscular system, or something of the kind.

Mr. Lyon: I think I can clarify that.

The Court: It is an ordinary term of physics, isn't it?

Mr. Lyon: That is right. That is right, your Honor. I think the witness had in mind—and I will bring it out——

Q. (By Mr. Lyon): That in this particular art, that is, the passive exercise body treatment art, that is where you draw this distinction, is it not, between vibration and oscillation?

A. Oh, yes, sir.

Q. That is what you had in mind?

A. Oh, yes, it is. That is what we are doing here.

Q. What is the Gunderman patent? What does it describe?

A. Well, it describes a vibrating machine, so

(Testimony of Bernard H. Stauffer.)

identifies it, as a portable vibrating machine. [332]

Q. Is it fair to state in the therapeutic treatment of the human body vibration and oscillation are two entirely separate, different things?

A. It definitely is, yes.

Q. They don't perform the same function, is that correct?

A. One might produce an adverse condition. In other words, vibration, you don't need to be a doctor to know that the body is antagonistic towards vibration in most instances.

While, if the motion is, let us say, compatible and the motion applied to the body that does not induce that tension, it might be considered and we consider it as oscillation.

Q. Referring again to the Gunderman patent, is there any device in there, indicated in that patent, even adding a couch to it, which could be used to give a Stauffer treatment to a patient?

A. The only one that has any similarity is that part which they have identified as a foot vibrator, but the arc in which it travels is corresponding to the motion of the—rather, the arc is identical with the hinge at the bottom, permitting it to go through a certain segment of circle there (indicating).

In so doing, you lose the lifting effect that is in the Stauffer motion. The platform lifts at the same time it goes back and forth. [333]

Q. That is what you mean by tiltingly oscillate, is that right?

A. Tiltingly oscillating. By permitting the top of

(Testimony of Bernard H. Stauffer.)

that to be rounded you miss the lifting effect entirely, and without that lifting effect you do not induce that motion into the anatomy, so essential to a Stauffer treatment.

In fact, it has been one of the most important parts of the success of the Stauffer table, the fact that it does induce that lifting action when applied to the pelvis. It gives the alignment or the postural effect that we have accomplished over these 20 years.

Q. And it is an important factor in obtaining that, that the applicator in a Stauffer patent is flat rather than curved, is it not?

A. Very much. Otherwise, you would never get the tilting action. It goes through the same plane all the time.

Q. Now, turn your attention to the Parker patent, No. 1,978,223, Defendant's D-1. I first ask you, could this mechanism—you don't have one?

A. Yes, I have.

The Court: There is a pretty good drawing of it there in the larger exhibit, if you want to put it up where he can see it. At least, it seems to accurately reproduce the drawings in the small soft copy. [334]

Mr. Lyon: We don't question that these are photostatic reproductions of the drawings.

The Court: All right.

Q. (By Mr. Lyon): I will first ask you if that device could be used to give a Stauffer treatment to a patient. A. No, it could not.

(Testimony of Bernard H. Stauffer.)

Q. Why?

A. On the weight of the body, as it is described in this illustration, the weight of the body would fall on these units that are illustrated here (indicating), and in order to make the proper alignment effect that the Stauffer table has, it must be done in unison at a section of the body; particularly the pelvis, where the motion is telegraphed all over the body in one motion.

As this is applied here (indicating), these units carry the weight of the body and act somewhat against one another. As this thing goes back and forth (indicating) you have a localized effect. Not a motion that is applied through the skeletal structure, but, rather, have a localized effect in each segment that touches the body. It is multiple, and you have carried the weight of the body over the entire top half of the body, rather than localized it in one spot.

You can't get the tilting action out of this because it hasn't the one platform that does—sends this one wave motion that induces the proper [335] alignment. You can't get it out of that design, by virtue of the fact it is multiple and it is localized to the pads at the position that they touch the body in their respective places.

Q. Mr. Stauffer,—

The Court: How much longer do you expect this will be? Are you just taking him through the cited art?



(Testimony of Bernard H. Stauffer.)

Mr. Lyon: I would like about another ten minutes with this witness.

The Court: You may certainly have it. But it would be much easier for us to reconvene at 1:30 than to continue on now, so we will take the recess until 1:30.

(Whereupon, at 12:00 o'clock noon, a recess was taken until 1:30 o'clock p.m. of the same day.) [336]

Monday, November 19, 1956—1:30 p.m.

The Court: Are you ready to proceed?

Mr. Lyon: Yes.

Mr. Harris: Yes, your Honor.

The Court: We will resume with the testimony.

### BERNARD H. STAUFFER

the plaintiff herein, called as a witness on behalf of himself, having been previously duly sworn, resumed the stand and testified further as follows:

#### Direct Examination—(Continued)

Q. (By Mr. Lyon): Mr. Stauffer, I show you Plaintiff's Exhibit 16,—first, I will ask you, did you hear the testimony of Dr. Knapp?

A. Yes, I did.

Q. He pointed out that in the Slenderella table, as exemplified by Plaintiff's 16, there were two arms which he marked 11 and 11-A, and he pointed out that in one cycle of the use of this machine those were locked together by clutches, so that they reciprocated in unison, that is, they were both in the same phase.

(Testimony of Bernard H. Stauffer.)

However, I do note there are two of them, and I call your attention to the fact that in your patent there is a single, what we have heretofore called applicators. [337]

I would like to have you compare the action of the Slenderella table, when it is in the phase which I have given you, where the two arms are operating in unison, with the action of your patent.

Mr. Harris: The court please, that is objected to as incompetent and irrelevant. Mr. Stauffer has admitted he never saw one of these Slenderella machines.

The Court: What about it, counsel?

Mr. Lyon: I submit he can read a drawing and he knows how they operate. He is quite an authority on these motions.

The Court: Overruled.

The Witness: If this 11 and 11-A were locked together and moving in unison, it would give the identical effect as it would in the Stauffer No. 1 table.

Q. (By Mr. Lyon): It would accomplish that same function, is that correct?

A. It would be identical in motion. It would accomplish the same thing and would virtually be the same thing.

Q. Now, in this Exhibit 16 we have some mechanism over here on the left-hand side of the table (indicating), which is designed to shake the whole table.

(Testimony of Bernard H. Stauffer.)

Do you employ any such mechanism in the Stauffer System?

A. Well, the Stauffer System since its inception has had what we term this No. 1 table, which is one platform in motion. [338]

And we have a No. 2 table, which are these two alternating, and we have a No. 3, which the entire top of the bed gives a faster and stimulating motion, which construction is very similar and, as explained to me, very similar to the one that is illustrated here (indicating).

Q. Would it be fair to say that the drawing which you have before you, Exhibit 16, incorporates the basic principles of three different Stauffer tables?

A. Yes, it does, it definitely does.

Q. And only one of them is the one you assert your patent covers?

A. That is right, only the No. 1 is all.

Q. Now, Mr. Stauffer, in 1950 you were in litigation in this court with one of your previous franchise holders, were you not?

A. Well,—

Q. Mrs. Exley?      A. Mrs. Exley, yes, I was.

Q. And did anything happen in the trial of that case that would cause you to re-examine your franchise structure?

Mr. Harris: The court please, the question gives a false implication. That case was never tried. The case never went to trial. I say that for counsel's information.

(Testimony of Bernard H. Stauffer.)

The Court: The question doesn't suggest it did.

Mr. Lyon: I am sorry,— [339]

The Court: "Did anything happen in that case?"

A lot of things happen in a case. They start happening when you hand the complaint to the clerk and he reaches in the drawer to see what judge draws it, and then puts a stamp on it.

Mr. Harris: I am sure Mr. Lyon misspoke himself.

Mr. Lyon: I will rephrase the question.

Q. (By Mr. Lyon): Did anything happen during the pendency of that case, Stauffer v. Exley, which caused you to re-examine your franchise system? That can be answered yes or no.

A. Yes, there was something that happened.

Q. What happened?

A. Well, I had a general counsel who employed Mr. Ford Harris in relation to the registered trade name that was being violated, and, of course, the Clayton Act was quite a subject in this—

Q. Let me shorten the whole thing. As a matter of fact, Mrs. Exley filed an answer in the case, did she not? A. Yes, she did.

Q. And the answer raised the question of whether or not your franchise system violated the antitrust laws, did it not?

A. That is correct.

Q. You were advised at that time it would be well to have counsel examine your franchise system, is that correct? [340]

A. Yes, Mr. Harris advised me to have some

(Testimony of Bernard H. Stauffer.)

of those corrections made, which I of course took immediate steps to do so, through my general counsel.

Q. I hand you Exhibits I and J to your deposition, and ask you if these are representative of your franchise agreements as of post-1950 or '51, when you re-examined your franchise agreements.

A. This was the one that was after 1950, that is correct (indicating).

Q. Those two agreements?

A. That is right.

Mr. Lyon: These two agreements are offered as Plaintiff's Exhibits next in order.

The Court: What is the foundation for them? You simply said they were exhibits to a deposition.

Q. (By Mr. Lyon): These are, are they not, Mr. Stauffer, exemplars of the current uniform agreement which you offered to franchise holders, is that correct?

Mr. Cox: We may be able to shorten this whole examination, because we are prepared to stipulate that in or about 1950 or 1951 the former franchise agreement employed by Mr. Stauffer was revised to eliminate the so-called price-fixing clause, Clause 8, and to eliminate the tie-in agreement clause, Clause 12.

Exemplars are already part of the file in this [341] case in responses to request for admissions which have been filed, which I assume your Honor considers as part of the entire file in the case, just as admissions to the answer.



(Testimony of Bernard H. Stauffer.)

Mr. Lyon: I am not exactly sure myself, Mr. Cox. That is why, out of an extra-abundance of caution, I would like to have these in the record.

I think the answers to request for admissions are more or less like an interrogatory; it is not in unless it is put in evidence.

The Court: Are you willing to accept his stipulation?

Mr. Lyon: I am accepting his stipulation.

The Court: Then you may put these in evidence, too.

Mr. Cox: Mr. Lyon, may we stipulate the request for admissions and responses thereto may be considered as evidence in the case?

Mr. Lyon: So stipulated.

The first one?

The Clerk: Plaintiff's Exhibit 20 for identification.

Mr. Lyon: The second one will be 21.

(The documents referred to were marked Plaintiff's Exhibits 20 and 21 for identification.)

The Court: Is there anything besides the tie-in agreement and the price-fixing agreement which you contend amounted to a violation of either the Clayton or the Sherman Acts?

Mr. Cox: There is a clause, your Honor, that is [342] also present in the current form of franchise agreement which probably violates Section 16600 of the Business and Professions Code of the State of California.

(Testimony of Bernard H. Stauffer.)

We do not take the position, however, that constitutes a more recent violation, for the purpose of application of the Sherman Act.

Q. (By Mr. Lyon): Mr. Stauffer, during the period of time when your franchise agreements contained a stipulation that the salon would maintain prices, did you ever take any active steps to enforce that provision of the contract?

A. No, we never took any active steps to enforce it. In fact, I am reasonably sure that every salon in the country had their own price. They may have had the \$2.00 price in a general manner, but each one gave a different discount for various reasons, which of course changed the price to the individual very often at the time they were making the sale, as to whether they could successfully make the sale or not.

Q. Mr. Mack was one of the persons that was licensed under your Stauffer System.

Did you have any particular discussion with Mr. Mack—and by “Mack” I mean the president of the defendant corporation here—concerning the maintenance of prices?

A. I think the only discussion we had was whether the price that they were charging—which I am sure wasn't strictly adhered to as far as the price [343] that we suggested—was whether it would be profitable for them, and I, after all, had an obligation of making these franchise holders successful.

We received no additional money if they charged

(Testimony of Bernard H. Stauffer.)

more or if they charged less. Our fees at that time were fixed. It was a fixed rental.

The only obligation we had to this individual was to see that they were successful. It was on that point that we based our whole conclusion.

Q. Now, at one time prior to 1950 or '51, when these contracts were revised, your contracts contained a clause in which the salon owner agreed not to use any equipment other than Stauffer's or Stauffer-authorized equipment.

Did you ever take any active steps to prevent the use in the salons of unauthorized equipment?

A. No, we never have.

Q. Were there any of the old type franchises which contained any of these provisions as to price fixing or as to the use of competing materials, machinery, in existence as, say, of January, 1952?

A. Would you state that again?

Mr. Lyon: Will you read it?

(The question was read.)

The Witness: I think they were practically all converted over by that time. I am just making that [344] guess, however; I am not positive.

But during that period of time they were in the transition stage and I would think they were mostly made over.

Mr. Lyon: You may cross examine.

Mr. Harris: No cross examination, the court please.

The Court: Thank you, sir.

(Witness excused.)

Mr. Lyon: The plaintiff rests.

Mr. Harris: Defendant rests.

The Court: Are you ready to argue your case?

Mr. Harris: Yes, your Honor.

The Court: All right.

Are you ready, Mr. Lyon?

Mr. Lyon: Yes. Shall I proceed?

The Court: Surely.

Mr. Lyon: As I stated in the opening part of the trial, this case has now been restricted to a charge of infringement of Claim 1 of the patent in suit.

Claim 1 is not restricted as to any degree of arc. It appears to me clearly and obviously infringed by the Slenderella tables.

The Slenderella table is a muscle-relaxing machine and it embodies a couch for the repose of the human body and it has a slotway in the top surface, through which a vertically directed and oscillatable support extends. It has, in fact, [345] a slotway through which two vertically directed and oscillatable supports extend.

There may be an argument based upon the fact that the claim states that the support is for a simple, flat, rectangular means. Mr. Stauffer has just stated—and I think it is clear beyond argument—that the two applicators of the Slenderella structure perform the same function and they do so in the same manner as the single applicator of the patent, or the claim, while they are locked together by the dog clutch, so as to operate in unison.

I do not have the authority with me here, but

ample authority can be cited to the effect that a device which is an infringement part of the time, and part of the time only, is nevertheless infringement. So that the mere fact that this device is convertible on one cycle to a device in which there are two supports moving in opposite directions does not free it from being an infringement.

Now, we think that we have here a duplication in two separate ways. It is elementary patent law that you cannot escape infringement where a patent calls for or shows a single element, by dividing that element into a plurality of elements which still perform the same function.

Walker on Patents, Diller's Edition, Section 462, collects and lists a long list of cases on the question of multiplication or duplication of parts. [346]

I have selected one or two who have very apt language to quote to the court. In the case of *Sutherland Paper Co. v. Auburn Carton Corporation*, 118 Fed. (2d) 862, at 864, the claim called for a carton comprising a blank cut and scored, and then it went on as to how it was folded and so on. It was an egg crate.

A blank is a single one-piece unit. The defendant took two pieces of paper and glued them together. The Court of Appeals inquired:

“Did the defendants avoid infringement by using two pieces of paper and gluing them together and thereby making one piece? For the purpose of determining infringement, defendants' two pieces, glued together, were one piece. Infringement was



not avoided by using two pieces and gluing them together.”

I submit that is what the defendant has done here. They have put two pads side by side and they have connected them by mechanical means, such as clutches, so they work together and perform the same function as the single applicator of the patent in suit, and they do so in the same way.

When locked together and forming a unitarian structure, these pads or applicators move as a unit, and it is apt to say of them, as is said in Claim 1 in the patent in suit, that they tiltingly move and they oscillate,

“\* \* \* axially of the length of said couch-like [347] structure whereby zonular areas of the body may be massaged by mechanical manipulation in a substantially horizontal plane.”

Infringement is thus clearly made up.

On the point of duplication of parts, I would like to cite a few more cases. *Samson-United v. Sears, Roebuck & Co.*, 103 Fed. (2d) 312, where it states:

“It is no departure from the patent to use a blank of blades instead of single blades or two-piece hub instead of a single-piece hub to accomplish the same result.”

Quoting from page 315.

I would like to cite the next case. It probably paid for my college education. *Stebler vs. Riverside Heights Orange Growers' Ass'n.*, 205 Fed. 735; one of my father's cases. It is leading in the Circuit.

That the adding of an additional function to a machine, if it would perform the function of the

patent in suit, it is immaterial that it will also do something else.

That is applicable here to the accused structure, when you reverse the electric motor and you get our No. 2 table, which is unpatented, instead of our No. 1 table, which is patented.

Mr. Harris will probably be heard to state that a single flat applicator of the patent in suit is a [348] limitation which cannot be overlooked because it was placed in the claim to overcome a rejection on Parker.

I believe that even if we accept that it is an important limitation. Its meaning is clear. It is still entitled to a range of equivalents.

What we were distinguishing from in Parker, when we put in a single applicator, was a series of applicators, one after the other.

The defendant does have a series of applicators, one after the other, which, as Mr. Stauffer testified, would be working against each other. But they do have a unitary structure, which is the full equivalent of the single applicator of the patent in suit. Mr. Harris may argue that some of the language of Claim 2 is in some manner or other imparted into Claim 1. And he will read from the specification of the patent—

The Court: I understood that neither of you were making any point about Claim 2.

Mr. Lyon: I believe that Mr. Harris will argue that language in Claim 1, in effect, means the same thing as Claim 2.

The Court: Are you going to contend that Claim 2 is involved in this litigation?

Mr. Harris: No. The plaintiff has disclaimed any infringement of Claim 2, and we are content with that. [349]

I will expect the court to make a finding, however, that Claim 2, in any event, is not infringed, in view of counsel's withdrawal of that claim.

Mr. Lyon: I will be very brief in that regard. It is very elementary patent law that where a limitation is in one claim, clearly set forth in one claim, and that limitation does not appear in another claim, a court will not impart the limitation into the other claim. It will read the claims as separately written and as covering entirely different scopes.

As the Supreme Court said, or, rather, as our Ninth Circuit Court has just quoted in the Winslow Engineering Company v. Smith case, 228 Fed. (2d) 332, decided December 14th of last year, and it quoted from Graver Tank & Mfg. Co. v. Linde Air Products Co., 336 U.S. 271, concerning this question of not reading elements from one claim into another claim. The Supreme Court said:

“It would accomplish little to require that claims be separately written if they are not separately read.”

So much on the question of infringement. I will not belabor it because I believe it is clear.

There is always present in a patent infringement case a question of invention. Nobody has ever been able to define “invention”. Congress tried to define

[350] it in a negative sort of way when they codified the law, but almost everybody agrees they haven't changed the law, except perhaps to negative any idea that an invention requires a flash of genius.

What do we do when we try to decide whether a device was obvious to a man skilled in the art or whether it was an invention? We see what it has done.

Since 1938, when Mr. Stauffer started out, Stauffer tables, embodying the invention of the patent in suit, were licensed all over the United States and in foreign countries. Mr. Stauffer has stated that over five million women have been treated by the invention of the patent in suit. The defendant has paid the compliment of imitation.

In *Landis v. Schick Dry Shaver* the Court of Appeals stated:

"Imitation has often been taken especially in this court as evidence of what the world should think of the invention and as conclusive evidence of what the defendant thinks of it."

This remarkable success, in a world teeming with competitors for the woman-figure dollar, is remarkable. There are all sorts of competing devices. Mr. Stauffer mentioned the Relaxacizor, and anybody who owns a television machine can't get very far from Vic Tanny and his gyms, which are not new things. [351]

Yet this patent, this system, this patent created a new system of treating the human body, which has been of great service to thousands and millions



of women and even some men. The home unit, such as we have in evidence here, is now being sold to the public. The Stauffer treatment—

The Court: I didn't get that. The home unit is what?

Mr. Lyon: Is now being sold to the public for use in offices and homes.

I think it is fair to say that the patent in suit created two great businesses, Mr. Stauffer's business and Mr. Lawrence Mack's Slenderella System.

The prior patents that are relied upon by the defendant here, the Parker patent was before the Patent Office, and you might say it was rejected by the Patent Office as not anticipating the claims in suit, because they allowed the claim we are standing on over the Parker patent.

We can see why. It does not embody the essential of the Stauffer movement. It has, as we say, applicators that are working against each other.

The Miller patent merely pokes a man in the back. It does not have an applicator adapted to tiltingly move axially of the couch.

Any tendency to have any such tiltingly movement of the applicator is effectively removed by the articulation at the pivot point 32. [352]

The remaining patent to Gunderman is a vibrating machine and could not be used to carry out the Stauffer treatment. It doesn't have a couch, so it couldn't possibly have a slotway formed in a couch. It couldn't possibly have an applicator moving axially of a couch. So it does not meet the claim of the patent in suit.



It would not teach anything in this art, either, as there is a profound difference between a vibrator which, as shown from the Miller patent, vibrates at 1,700 R.P.M., and what the plaintiff and the defendant are doing here, which is in the neighborhood of 130 to 150 R.P.M.

I notice the court paying particular attention, and at the risk of being repetitious, if you have a force resting downwardly, a weight resting downwardly upon this applicator 27 (indicating), which, incidentally, is described in the patent as being pivoted about 32, so it can adjust itself to the back of a patient, so when a person puts his back on that thing, that would tilt up until it adjusted to the back, and then when you start swinging this arm in this direction (indicating), and there was a component of motion in that direction (indicating), it would simply mean the other one would fold back, in order that the pad could remain in firm contact with the back of the patient.

The over-all resultant would be, as the patent itself states, an upward push, which is certainly [353] foreign to the Stauffer invention and the claim which we are standing on.

I believe that will conclude my opening remarks.

Mr. Harris: May it please the court, my primary function, as I understand it, in making a closing argument, is to be helpful to the court. I am prepared to argue this case at great length and go into all the details of the evidence. I don't want to labor or belabor any of the points that your Honor may not think are helpful. So I suggest if

I do argue something that your Honor is satisfied on, that your Honor will stop me.

First, if the court please, infringement, patent infringement is not a mere matter of words. We don't just read a patent claim and then see whether it reads on its face on a defendant's accused structure. We must take the claim in the light of the specifications and drawings, in the light of file wrapper history claim, in the light of the prior art. And it is the plaintiff's burden, in any patent infringement case, on the issue of infringement to prove three things.

First, that the defendant's accused structure has the same elements set forth in the claim in suit.

Secondly, that those elements operate in substantially the same way as the elements of the claim of the patent in suit.

And, thirdly, that the defendant's machine achieves the same or substantially the same result [354] as the machine of the patent in suit.

In this case we are concerned only with the Stauffer patent and the question as to whether it is infringed by the defendant's machine. Counsel has tried this case on a comparison of plaintiff's machine with that the machine of the defendant. But we suggest it is wholly immaterial what the plaintiff's machine is.

What we are concerned with is the machine shown and described in the patent in suit, and the comparison of that machine with the defendant's machine.

I wish to consider those three elements of in-

fringement separately. First, whether the defendant's machine has the same elements as set forth in Claim 1 of the patent in suit.

Secondly, whether the elements in the defendant's machine operate in substantially the same manner as that of the patent in suit.

And, thirdly, whether the elements of the defendant's machine achieve the same result.

We suggest, of course, first, that the defendant's machine does not have the elements of Claim 1 of the patent in suit, even if we take those elements at their face value in the claim.

First, Claim 1 specifies a single applicator in line 6 of Claim 1. The defendant's machine, as the evidence shows, has double applicators side by side.

That word "single" in Claim 1 is very important because, as that claim was originally submitted to the Patent Office as Claim 10 of the Stauffer application for a patent, and it appears on page 24 of the file wrapper of the patent in suit, and as originally submitted, it was submitted without the words "single applicator" in the claim.

Claim 10 of the application was then rejected by the Patent Office on this Parker patent we are speaking of, which has double applicators.

The Court: More than double, isn't it?

Mr. Harris: Yes.

The Court: Multiple.

Mr. Harris: It shows six applicators, each one of which is double. If we consider any single applicator, it is a double applicator as is the defendant's construction.

That appears a little more clearly in Figure 4 of the drawings of the Parker patent. Taking an end view of one of these applicators, it is very plain that Parker shows in each applicator—well, each set of applicators is double. It has two applicators, one on each side of the center line. Those applicators move together, just as do the defendant's applicators.

So in response to the rejection by the Patent Office of Claim 10 of the Stauffer application on this Parker patent, the applicant, Mr. Stauffer, [356] through his attorneys, amended Claim 1 of the Stauffer patent application to insert the word "single" before "applicator" in Claim 1. That appears at page 24 of the file wrapper.

It wasn't until they did that—so amended Claim 1 to insert the word "single"—that the claim was allowed.

Thus the words "single applicator" are very material and it was by so amending the claim that Mr. Stauffer laid the foundation for its allowance.

The word "flat" in Claim 1, it says, "flat applicator"—"flat rectangular applicator". That word is very important.

The applicator 18 of the Stauffer patent in suit is flat. As distinguishing from the Parker patent, in which the applicators are rounded on the top, the Stauffer patent shows the flat applicator 18.

The importance of that was brought out very well this morning by Mr. Stauffer's testimony, where he was distinguishing his patent construction from the Gunderman patent. In the Gunder-



man patent, if your Honor will recall, the applicator is a curved plate 26.

Mr. Stauffer pointed out that by using a curved plate you do not get the uplift or lifting-up motion that is required to attain the results contended for by the Stauffer patent in suit.

Whereas, with his applicator he gets the lifting, [357] so we suggest, if the court please, that the word "flat" in the claim is also a material limitation, and since the defendant's applicators are rounded, quite similar to the Gunderman patent, we get the same result as Gunderman. Either we don't infringe or the patent in suit is invalid.

But, in any event, we do not have a flat applicator. Our applicators are rounded. It shows very clearly in Defendant's Exhibit C, in which the applicators are quite rounded, very similar to the Gunderman patent.

So we suggest that the defendant does not infringe by the omission of the element "a flat applicator". Defendant does not use a single applicator.

On either of those two grounds we say, if the court please, that the defendant's machines do not infringe this patent in suit.

Now, the next important words in Claim 1 are these words "tiltingly move". There has been a lot of evidence on that, the meaning of those words.

Again, the word "tiltingly" was not in Claim 1 when it was originally submitted to the Patent Office, as appears on page 24 of the file wrapper. The claim was rejected on Parker, the Parker patent, and in response to that rejection Mr. Stauffer's



counsel amended Claim 1—then Claim 10 of the application—to add the word “tiltingly” to distinguish from a type of motion found in Parker, in [358] which the applicators move through an arc on both sides of the vertical, just as they do in the defendant’s machines.

Dr. Knapp pointed out that to him the word “tiltingly” means and can only mean a movement in which the applicator support 20 in the Stauffer patent is at all times tilted with respect to the vertical. And he adverted to several places in the specification of the patent where that is described.

That was the word that was added in response to the rejection on Parker and as a material limitation. Since the defendant’s tables do not move in that way, that jerky movement on one side of the vertical, we suggest, if the court please, that they do not infringe.

As your Honor will recollect, in the original application for the Stauffer patent the drawings originally, as shown in the file wrapper, the original drawings, the enlargement of which is on the easel on the board here, in the original drawings submitted to the Patent Office the applicator was shown to move on both sides of the vertical, by the dotted lines in Figure 2 of the application drawing.

Claims were submitted to the Patent Office in the original application, Claims 2, 3, 4, 5 and 6, which appear at pages 9 to 11 of the file wrapper. Those claims were all limited to a machine having

“\* \* \* body contacting member extending through [359] the top surface of said couch and extending

in a plane horizontal with the top surface thereof, \* \* \* ”

In other words, those claims originally submitted in the Stauffer application were expressly limited to an applicator, which in one position was horizontal, just as is shown in the original drawing of the Stauffer application.

Those claims would have read directly upon the defendant's machine. Those claims were rejected on the Parker patent and on other prior art, and it was then that Mr. Stauffer's attorney amended his patent application to strike out the original drawing and to substitute the drawing which appears in the patent as issued, to add to the specification of his patent all this detailed material which describes the movement as being limited to one side of the vertical.

It was in response to that rejection that those amendments were made to the specification and to the claims.

In that connection, to illustrate how far this went, Claim 5 of the original application, from which I have just read, the statement that the  
“\* \* \* oscillatable member extending through the top surface of said couch and extending in a plane horizontal therewith, \* \* \* ”

means the very thing shown in the original Stauffer drawing. The very thing described in the original application.

Then, as I said, that claim was rejected on the [360] prior art and then Mr. Stauffer's attorney amended that claim to change the claim to say:

“\* \* \* an oscillatable member extending through the top surface of said couch and extending in a plane constantly inclined from the horizontal. \* \* \*”

In other words, he changed it from a plane parallel to the top of the couch to a plane constantly inclined with respect to the top of the couch. That claim was subsequently rejected and finally abandoned.

At any rate, that word “tiltingly”, we suggest, in Claim 1 is an extremely important word and by its insertion and by the amendments of the specification and the drawings Mr. Stauffer is now estopped to contend for any interpretation of Claim 1. It covers exactly the thing that he originally claimed, he originally showed in his application, and then canceled out in response to the rejection of the Patent Office, which we say is an abandonment and a dedication of that particular matter to the public.

We suggest that Mr. Stauffer, having so limited his application and his claims and his specifications, cannot now ask this court to expand his claim to cover that which was originally shown and described in the claim and then canceled.

So we suggest, if the court please, that the defendant's machines are not infringed because they [361] do not have the same elements set forth clearly in Claim 1. They do not have a single applicator, they do not have a flat applicator, and, lastly, the applicators do not tiltingly move on one side of the vertical, but move through the same arc of

movement as in the Parker patent and in the Gunderman, and, therefore, there is no infringement.

I might also say that Claim 1, in addition, contains a further important word, and that is the word "axially". It says:

"\* \* \* and means to oscillate said applicator axially of the length of said couch \* \* \*"

The evidence shows there are two applicators in the defendant's machines which operate separately on each side of the center line of the couch. They do not operate on the center line, which is the axis of the couch. Whereas, in the Stauffer patent there is a single applicator on the center line of the couch.

For that reason we say the defendant's machines do not have the elements, the clear elements set forth in the claims.

If we construe these words, "single", "flat", and "tiltingly", to cover the defendant's machines, then we suggest that Claim 1 reads equally well on the Parker patent, on the Miller patent, as it does on the defendant's structure.

In this matter of file wrapper estoppel, Mr. Lyon said he would like to see some authorities on that [362] point, and in addition to the authorities to set forth in our pretrial memorandum I wish to cite the following case as being in point on the same question of abandonment and file wrapper estoppel, that is, the case of *Aeration Processes, Inc. v. Lange*, 196 Fed. (2d) 981, which was a decision very recently in the Eighth Circuit Court of Appeals.



That case also holds that a patentee by cancellation of material from his specifications is estopped to contend for any interpretation of his claims in the issued patent that cover the forms of the invention originally described, but then canceled from his application.

Now, the next point on lack of infringement, the second element of plaintiff's case in proving infringement was that the elements must operate in the same way in the defendant's machines as they do in the plaintiff's patent—not the machine, but the plaintiff's patent.

It is our contention, of course, that the plaintiff has made no attempt here to prove that the defendant's machines operate as does the machine shown and described in the plaintiff's patent, and this is the only issue we are concerned with here.

The proof we suggest is very clear to the contrary, that the defendant's machines do not operate in the same manner nor have the same mode of operation as that of the machine of the plaintiff's patent. As I have said, in the defendant's [363] machines the applicators do not move axially, they move on each side of the axis—I mean in the defendant's machines they move that way, whereas in plaintiff's patent they move axially.

As Mr. Stauffer pointed out this morning, the applicator of his patent moves in a tilted fashion to get this uplifting of a body on this thing. Whereas, the evidence is that neither the defendant's machines nor the Gunderman patent have any such uplifting of the body.



In other words, in that respect that do not have, the defendant's machines do not have the same mode of operation as the plaintiff's patented machine. The defendant's machines have convex pads which do not provide any uplift to the body.

Dr. Fishbein's testimony was very clear to that effect, there is no uplifting effect by reason of the Slenderella machine operations.

In the defendant's Slenderella machines the movement, of course,—

The Court: Of course, if you had had him testify a little further he probably would have said there wasn't in the plaintiff's, either.

Dr. Fishbein didn't seem to think the human body reacted the way that the Stauffer patent says it would react to the application of this Stauffer construction.

Mr. Harris: That is right. We must remember [364] that the Stauffer patent discloses and describes quite a different thing than Mr. Stauffer manufactures and uses.

The machine showed in the Stauffer patent, in it the applicator moves only through that small arc of movement on one side of the vertical, which is not true of the Stauffer machine. The Stauffer machine moves just like Gunderman and the defendant's machine.

We are not trying a lawsuit comparing the plaintiff's machine with the defendant's machine. We are comparing what is shown and described in his patent with the defendant's machine.

The Court: The patent doesn't look a great deal like Gunderman, does it?

Mr. Harris: No, of course, it doesn't look like Gunderman, your Honor. What we are saying on that is simply that the Gunderman machine is a machine of the same general type as the defendant's machine, and if the plaintiff expands his claim to cover the defendant's machine, by the same token he is expanding his patent claim to cover the Gunderman machine, the Miller machine, the Parker machine. That goes to the question of validity more than it does to infringement, but it is relevant on both issues.

As shown by the evidence, the defendant's applicators in their movement, the applicator supports in their movement do not even overlap in any way [365] the arc of movement described and illustrated in the patent in suit. That is illustrated by this simple Keno-Matic model.

The Court: Let's determine this question of validity first. I think there is no great purpose in going into a close comparison for the purpose of infringement, unless we have a valid patent in the first instance.

Mr. Harris: Yes, your Honor. As we all know, only Claim 1 of the patent is involved in this action. If the court holds Claim 1 invalid, the plaintiff still has his patent with Claim 2 in it for whatever it is worth; the claim that covers in detail the actual construction and operation of the Stauffer machine.

So the invalidity of Claim 1 does not affect Claim

2 in any way. Mr. Stauffer keeps his patent on Claim 2.

But as to Claim 1, we suggest, first, that the court can disregard all the evidence in this case and read Claim 1 and find Claim 1 is invalid on its face, as not constituting an invention, as not covering an invention, under the authority of the Supreme Court in the Great Atlantic and Pacific Tea Company case and many, many decisions of our Court of Appeals.

We suggest that this assemblage that Mr. Lyon says is covered by Claim 1 of the patent in suit, all the elements are old there. There was nothing more than at best mechanical skill in putting them together to make a machine that would perform those functions. [366]

In that connection I think it is interesting and helpful to read what Mr. Lyon says Claim 1 covers in his pretrial memorandum, and I quote:

“The patent device is quite simple, consisting simply of a couch having an open section or slot in which is reciprocatively mounted a flat applicator or pad to tiltingly move in the slot to manipulate or massage a portion of the body of a patient.”

Couches are old in the art. Couches having slots in their top are old, couches having slots in their top through which an applicator or pad extends are old.

If the defendant's applicator moves in this tilting fashion we are talking about, all the prior art devices in the same type of arc, that is old, and they all manipulate or massage a portion of the body.

If that is all this Claim 1 amounts to the claim obviously is invalid on its face; we suggest there just is no invention in it.

The Court: Let's hear what Mr. Lyon has to say in reply.

Mr. Harris: Yes.

The Court: It seems to me invention is the big hurdle that you have here, Mr. Lyon.

Mr. Lyon: All right, sir. Invention is always a problem because it is an undefinable subject. It is—— [367]

The Court: At least, it has not been defined. Maybe sometime some legislative body or court will get around to really writing a definition.

It is said there is nothing which we can understand which is undefinable, but I haven't seen a good definition.

Mr. Lyon: You never will, sir. The difficulty is there are two schools of thought as to how to determine invention.

If you take the subjective school, then we find, if we went through many years in which our judges were holding all patents invalid for want of invention, by applying a subjective test which more or less came down to this: "If I can understand it, it is too simple to be invention."

We don't think that is the proper test, and we would contend more for the objective test of invention. The objective test of invention, and it seems to me the more proper test, is what did the invention do, what did it accomplish.

There are certain criteria that are increasingly

applied by the courts. One of them is, "Did it supplant something that went before it?" Another one is, "Did it fill a long-felt want?" Another one is, "Did it increase production," such as in the Ibelle Process case.

What we have here, we have no predecessor so we can't compare the performance of the Stauffer invention to any preceding invention. These prior [368] devices in the prior art were simply paper patents that never saw the light of day. So we can't show this court where Gunderman or Miller have been driven off the market by the Parker device.

But we do have the fact that this created an immense business.

Now, this commercial success will not be considered in a case where there is a clear want of invention. But it doesn't seem to me this is a case where there is a clear want of invention.

The combination set forth by the claim, which we are relying upon, is a new combination. It is entitled to the benefits of whatever uses it can be put to.

Let's assume that Dr. Fishbein is correct and we can't cure these diseases, we can't do these beneficial things to the human body that we think we can do, even he admits that we get passive exercise. There was no passive exercise available until the Stauffer System came along, and it did it with a combination. That combination first had to have a couch so that the part of the body which is not being actively attacked, you might say, by the



applicator, can relax, and that the weight of the remaining part of the body can act as an anchor against which we manipulate the portion of the body which we are manipulating.

So the couch is an important and effective and necessary element of the claim. That rules out any [369] such anticipation, for instance, as for instance Gunderman. Gunderman, or course, was a vibrator and even if applied to a couch it wouldn't give the sort of stuff we are looking for.

If Gunderman is out, then we have only to contend with Parker, who is a file wrapper reference, and Miller. Parker, as the court has very aptly noted, has a series of six double applicators. That means that six separate zones of the body of a patient are being attacked at once, which is entirely foreign to our idea of attacking what the patent claim calls a zonal area, a single zonal area.

Finally, Miller, as Mr. Stauffer has indicated, isn't a manipulator at all. It just merely is a pressure instrument for pressing upward on the back of the body, as those straps across the chest and abdomen are tightened. I notice that the defendant's expert didn't even bother to explain that, but these straps in the Miller patent are also attached down below to the vibrating mechanism or the manipulating mechanism, so that they are cinched down as the pad 27 comes up (indicating), so that in effect you are giving an artificial respiration type treatment to the patient.

Now, does any of that prior art teach the invention of Mr. Stauffer? Does Parker? Does Parker

teach you a passive exercise table in which the majority of the body is supported on a flat table while the zonal area is manipulated against that?

I submit that he has not a head rest, and then substantially—at least, half of the body of a patient will be on the applicators. It is certainly a different thing from either what the plaintiff in this case does or what the defendant does.

Finally, Gunderman, does he teach the Stauffer invention? I submit he would not even be a relevant consideration.

We are thinking, “What would a man skilled in the art be able to do? Would he be able to synthesize the Stauffer invention from what was known in the art?”

Well, now, he wouldn't even go to Gunderman, he wouldn't go to vibrating devices that are designed to operate at 1,700 R.P.M. when he is thinking about building a device for passive exercise of the human body. He wouldn't even be looking in that bin.

So in view of the fact that as an objective fact, as a matter of evidence this patent has created a new industry; he has made both the defendant and the plaintiff into great international systems. I think it would be somewhat presumptuous for any of us to say, “That is no invention, I could have thought of that myself.”

And if it is no invention, if it is such a simple thing, if it is anticipated by the prior art, why doesn't the defendant use the prior art? The defendant can use another table if he wants to. The

defendant can use the Parker apparatus if he wants to.

But I submit on this record it is clear, having once been a licensee, having once been one of our own managers, this defendant knew that there was something important in this invention, that there was a real invention here and he therefore copied it.

The Court: Since both counsel have taken the view that only Claim 1 is involved here, I think some of the pleadings refer to Claim 2, but since everyone agrees on Claim 1 being the only claim involved in the litigation, that is the only one the court will undertake to adjudicate.

The court cannot see a great deal of similarity between Miller, Gunderman, Parker and Stauffer. They have some things in common, but it cannot be said that these that I have just enumerated anticipate Stauffer in the way that prior art is supposed to anticipate with respect to patent law.

However, the art that is involved in Stauffer is a simple art. I don't think your test, Mr. Lyon, that it is something we would have thought of, is a test to be applied, either. The test which we are to apply in determining invention, if we follow what the courts tell us, is whether the thing that is claimed to be an invention could have been conceived by the person having the usual skills in that art. [372]

Now, this art is a simple art, and the court feels that it is so simple that the structure which has been developed here by Mr. Stauffer is a structure which could reasonably be expected to have been

developed by one having ordinary skill in that art and that it just does not rise to the level of invention, as invention is protected by the patent laws.

That doesn't require us to make any finding concerning the accused structure. That is, having found that Claim 1 of the patent is invalid for want of invention, there is no need to determine whether the accused structure is one which would infringe had we here a valid claim, so I will not find on the accused structure.

But Mr. Harris has been looking unhappy during everything I have said.

Mr. Harris: No, your Honor, I am very happy. I didn't want to seem to be too happy.

The Court: The first counterclaim seeks declaratory relief, and in a sense you get that by the adjudication that Claim 1 is invalid for want of invention. I don't think there is anything in the evidence which calls for us to go further than that.

The counterclaim based upon an allegation that the Clayton Act has been violated has been withdrawn, so there is no need to find upon that. [373]

Will you prepare findings, counsel?

I am not going to find on file wrapper estoppel, either. I don't think that is necessary to the adjudication here and courts should not go further than necessary to determine the litigation immediately before them.

Mr. Harris: Yes, your Honor.

The Court: Will you prepare findings, conclusions and judgment, Mr. Harris?

Mr. Harris: Yes, I shall.

The Court: Adjourned.

(Whereupon, at 2:45 o'clock p.m., Monday, November 19, 1956, an adjournment was taken.) [374]

[Endorsed]: Filed Jan. 15, 1957.

---

[Endorsed]: No. 15418. United States Court of Appeals for the Ninth Circuit. Bernard H. Stauffer, Appellant, vs. Slenderella Systems of California, Inc., a corporation, Appellee. Transcript of Record. Appeal from the United States District Court for the Southern District of California, Central Division.

Filed: January 21, 1957.

Docketed: January 23, 1957.

/s/ PAUL P. O'BRIEN,

Clerk of the United States Court of Appeals for the  
Ninth Circuit.



In the United States Court of Appeals  
for the Ninth Circuit

Appeal No. 15418

BERNARD H. STAUFFER, Appellant,

vs.

SLENDERELLA SYSTEMS OF CALIFORNIA,  
INC., Appellee.

STATEMENT OF POINTS ON APPEAL

The points of error of the District Court which plaintiff intends to urge on Appeal from the Judgment of the Court in favor of defendant in the above-entitled action are as follows:

I.

The District Court erred in finding that Claim 1 of said Letters Patent No. 2,240,679 in suit defines an assemblage of elements all of which were old in the prior art in which they operated in substantially the same way to produce substantially the same result, and such subject matter as a whole would have been obvious to and could have been produced by any person having ordinary skill in the art to which said subject matter pertains.

II.

The District Court erred in finding that Claim 1 of said Letters Patent No. 2,240,679 is wanting in invention.

## III.

The District Court erred in failing to find that Claim 1 of Letters Patent No. 2,240,679 is infringed by defendant by the use of tables by defendant exemplified by plaintiff's Exhibits 16 and 17.

## IV.

The District Court erred in concluding that Claim 1 of said Letters Patent No. 2,240,679 is invalid and void in law for lack of invention.

## V.

The District Court erred in concluding that the defendant, Slenderella Systems of California, Inc., is entitled to judgment against the plaintiff, Bernard H. Stauffer, dismissing the complaint with prejudice.

## VI.

The District Court erred in concluding that the defendant, Slenderella Systems of California, Inc., is entitled to judgment on its first counterclaim herein for declaratory relief, adjudging claim 1 of said Letters Patent No. 2,240,679 in suit invalid and void.

## VII.

The District Court erred in failing to conclude that Claim 1 of Letters Patent No. 2,240,679 is valid.

## VIII.

The District Court erred in failing to conclude that Claim 1 of Letters Patent No. 2,240,679 is infringed by defendant by the use of tables by defendant exemplified by plaintiff's Exhibits 16 and 17.

IX.

The District Court erred in ordering, adjudging and decreeing that Claim 1 of United States Letters Patent No. 2,240,679 is invalid and void in law.

X.

The District Court erred in dismissing the complaint and ordering that the plaintiff shall take nothing by his complaint herein.

XI.

The District Court erred in ordering, adjudging and decreeing that the First Counterclaim for declaratory relief adjudging Claim 1 of United States Letters Patent No. 2,240,679 invalid and void is hereby sustained.

XII.

The District Court erred in failing to adjudge that Claim 1 of Letters Patent No. 2,240,679 is valid and infringed by defendant.

XIII.

The District Court erred in granting defendant judgment for costs herein, and particularly allowing \$991.36 for defendant's Exhibits E, F, G, H, I and J and \$30.50 for defendant's Exhibit K.

Dated this 22nd day of January, 1957.

LYON & LYON,

/s/ By CHARLES G. LYON,

Attorneys for Appellant.

Affidavit of Service attached.

[Endorsed]: Filed Jan. 23, 1957. Paul P. O'Brien, Clerk.

[Title of Court of Appeals and Cause.]

### DESIGNATION OF EXHIBITS

Book of exhibits, fifteen copies to be printed, containing:

Plaintiff's Exhibit 1—Flat copy of Stauffer Patent No. 2,240,679;

Photostatic copies of Exhibit 15—The Slenderella-Stauffer Release;

Defendant's Exhibits D-1 — Parker Patent No. 1,978,223,

D-2—Miller Patent No. 1,953,424, and

D-3—Gunderman Patent No. 1,825,588;

Defendant's Exhibit L—

1. Taylor Patent No. 86,604
2. Hardy Patent No. 1,276,526
3. Hardy Patent No. 1,391,893
4. Iverson Patent No. 1,602,196
5. Rosenquist Patent No. 1,616,065
6. Torrence Patent No. 1,910,135
7. Hardy Patent No. 1,999,412
8. Snyder Patent No. 2,036,371

The following to be treated as physical exhibits:

Exhibit 2—The Home Unit

Exhibit 3—The Movie

Exhibit 4—The Skeleton

Exhibits 5 & 6—Stauffer Booklet

Exhibits 7 through 11—Stauffer Name Plates

Exhibit 12—Minimum Price Schedule

Exhibit 13—Price List

Exhibit 16—Slenderella Drawing

Exhibit 17—Slenderella Drawing

Exhibit 18—Kinematic Model of Exhibit 16

Exhibit 19—Kinematic Model of Exhibit 17

Defendant's Exhibits:

A-1, A-2 & A-3—Drawings of Stauffer Machine

B-1—File Wrapper of Stauffer Pat. No. 2,240,-  
679

C—Drawing illustrating Slenderella Motion

E—Photographic Enlargement of Figure 6 of  
Gunderman Patent No. 1,825,588

F—Kinematic Model of Gunderman Patent No.  
1,825,588

G—Photographic Enlargement of Figures 4, 5 &  
6 of Miller Patent No. 1,953,424

H—Kinematic Model of Miller Patent No.  
1,953,424, Figure 4

I—Photographic Enlargement of Sheet 1 of Par-  
ker Patent No. 1,978,223

J—Kinematic Model of Figure 2 of Parker Pat-  
ent No. 1,978,223

K—Drawing with movable arm.

Concerning the books of exhibits, appellant will furnish fifteen copies of Exhibits 1, D-1, D-2, D-3, and L-1 through L-8. We ask the Clerk to secure fifteen photostatic copies of Exhibit 15.

Exhibits identified at the trial, other than those listed as physical exhibits or to be made a part of the book of exhibits, were not admitted in evidence.



Dated this 29th day of January, 1957.

LYON & LYON,  
/s/ By CHARLES G. LYON,  
Attorneys for Plaintiff-  
Appellant

Affidavit of Service attached.

[Endorsed]: Filed Jan. 30, 1957. Paul P. O'Brien, Clerk.

---

[Title of Court of Appeals and Cause.]

#### SUPPLEMENTAL DESIGNATION

Some question having arisen as to whether the appellant has properly designated the record in accordance with R.C.P. 75 and Rule 17.6 of this Court, please be advised that the appellant designates the entire record as certified by the Clerk of the District Court as the record on appeal in this case, including all of the pleadings, all of the exhibits received in evidence and the entire transcript of the trial, all to be printed with the exception of the exhibits designated as physical exhibits in the designation of exhibits heretofore filed.

Dated: February 1, 1957.

LYON & LYON,  
/s/ By CHARLES G. LYON,  
Attorneys for Plaintiff-  
Appellant

Affidavit of Service attached.

[Endorsed]: Filed Feb. 4, 1957. Paul P. O'Brien, Clerk.

[Title of Court of Appeals and Cause.]

APPELLEE'S DESIGNATION

Appellee in the above-entitled appeal hereby designates that Defendant's Exhibit B-1, the file-wrapper and contents of patent No. 2,240,679 in suit, should be printed as a part of the printed record on appeal.

Dated: February 5, 1957.

HARRIS, KIECH, FOSTER &  
HARRIS,

FORD HARRIS, JR.,

/s/ By FORD HARRIS, JR.

NEWLIN, TACKABURY &  
JOHNSTON,  
HUDSON B. COX

Attorneys for Appellee.

Affidavit of Service attached.

[Endorsed]: Filed Feb. 6, 1957. Paul P. O'Brien,  
Clerk.

[illegible]

[illegible]

[illegible]

[illegible]

[illegible]

[illegible]

[illegible]

[illegible]

[illegible]

[illegible]

[illegible]

[illegible]

[illegible]

[illegible]

[illegible]

[illegible]

[illegible]

[illegible]

No. 15418

IN THE

# United States Court of Appeals

FOR THE NINTH CIRCUIT

---

BERNARD H. STAUFFER,

*Appellant,*

*vs.*

SLENDERELLA SYSTEMS OF CALIFORNIA, INC.,

*Appellee.*

---

APPELLANT'S OPENING BRIEF.

---

LYON & LYON,

CHARLES G. LYON,

811 West Seventh Street,  
Los Angeles 17, California,  
Michigan 3901

*Attorneys for Plaintiff-Appellant*

FILED  
MAY 18 1957  
U.S. COURT OF APPEALS  
NINTH CIRCUIT  
LOS ANGELES, CALIF.





## TOPICAL INDEX

	PAGE
Jurisdiction .....	1
Statement of the case.....	2
Specification of errors.....	4
Summary of argument.....	6
Argument .....	7
The District Court erred in concluding that the Stauffer device is too simple to be an invention.....	7
The District Court erred in failing to apply the rule that where the purpose and result are different, very slight struc- tural changes over the prior art are enough to sustain a patent .....	9
The District Court erred in failing to find infringement of Claim 1 .....	13
Conclusion .....	14

## TABLE OF AUTHORITIES CITED

CASES	PAGE
Aronson v. Toy Devices, Inc., 1 F. 2d 91.....	8
Baldwin-Southwark Corp. v. Tinius Olsen Testing Mach. Co., 88 F. 2d 910.....	8
Barry v. Harpoon Castor Mfg. Co., 209 Fed. 207.....	7
Brick v. A. I. Namm & Sons, 22 F. 2d 693.....	7
Gandy v. Main Belting Co., 143 U. S. 587.....	7
Inland Mfg. Co. v. American Wood Rim Co., 14 F. 2d 657.....	7
Jensen-Salsbery Laboratories v. Salt Lake Stamp Co., 28 F. 2d 99 .....	7
Krementz v. S. Cottle Co., 148 U. S. 556.....	7
Kurtz v. Belle Hat Lining Co., 280 Fed. 277.....	12
Lane v. Craftsmen Film Laboratories, 7 F. 2d 288.....	7
McKee v. Graton & Knight Co., 87 F. 2d 262.....	8
Patterson-Ballagh Corp. v. Moss, 201 F. 2d 403.....	8
Pointer v. Six Wheel Corporation, 177 F. 2d 153.....	10, 12
Postage Meter Co. v. Standard Mailing Machine Co., 9 F. 2d 19 .....	7
Potts v. Creager, 155 U. S. 597.....	7
Research Products v. Tretolite Co., 106 F. 2d 530.....	12
Robert W. Brown & Co., Inc. v. De Bell, 113 U. S. P. Q. 172 .....	6, 8
Ryan v. Goodwin, Fed. Cas. 12186.....	6, 8
Silver-Brown Co. v. Sheridan, 71 F. 2d 935.....	8
Smith v. The Dental Vulcanite Co., 93 U. S. 486.....	12
Stebler v. Riverside Heights Orange Growers' Association, 205 Fed. 735 .....	12

	PAGE
The Barbed Wire Patent, 143 U. S. 293.....	7
Topliff v. Topliff, 145 U. S. 156, 36 L. Ed. 661.....	9
Traitel Marble Co. v. U. T. Hungerford Brass & Copper Co., 18 F. 2d 66.....	10
United Shoe Machinery Corp. v. E. A. Ferree Co., 64 F. 2d 101 .....	8
Warren Telechron Co. v. Waltham Watch Co., 91 F. 2d 472....	8

#### STATUTES

United States Code, Title 28, Sec. 1291.....	1
United States Code, Title 28, Sec. 1338.....	1



No. 15418  
IN THE  
**United States Court of Appeals**  
FOR THE NINTH CIRCUIT

---

BERNARD H. STAUFFER,

*Appellant,*

*vs.*

SLENDERELLA SYSTEMS OF CALIFORNIA, INC.,

*Appellee.*

---

**APPELLANT'S OPENING BRIEF.**

---

This is an appeal from the judgment of the District Court for the Southern District of California (Tolin, Judge) dismissing an action for patent infringement [R. 50]. Judgment was entered on findings and conclusions [R. 48-50] based upon an oral opinion at the close of trial [R. 380-381] that Claim 1 of Stauffer Patent No. 2,240,679 is invalid.

**Jurisdiction.**

This suit arises under the patent laws. Jurisdiction of the District Court is founded on 28 U. S. C. 1338. Appellate jurisdiction of this Court is based upon 28 U. S. C. 1291. Judgment was entered November 27, 1956. This appeal was taken December 12, 1956, within the statutory period.



### Statement of the Case.

Stauffer Patent No. 2,240,679 in suit relates to a muscle relaxing machine of the type used for treating patients with "Passive Exercise," and it is plaintiff's contention that such machines are used throughout the entire nation in the well-known Stauffer System and Slenderella System reducing salons. The patent [R. 392] is indeed simple. Briefly summing it up, it comprises a couch 10 with an opening in it in which an applicator, denominated a seat 18, extends which is carried by legs 20 which rock about pivots 21 when driven by motor 50 through belt 52, pulley 48 and pitman 28.

The accused structures are shown by physical Exhibits 16-19, inclusive, and in each case are found to be couches with an opening, in which are mounted applicators carried by legs which are rocked through small arcs by a pitman driven by a belt system and electric motor.

The pleadings are complicated by the presence of a counterclaim under the Antitrust Laws and the addition of another party, but this counterclaim was dropped during the trial [R. 337], so all that remains in the case is a simple complaint for infringement by plaintiff Stauffer against defendant Slenderella Systems of California, Inc., and a counterclaim for declaratory relief against the patent.

Claim 1 only of the patent is relied upon. It reads as follows:

"1. A muscle relaxing machine comprising a couch-like structure for repose of a human body in

the top surface of which a slot-way is formed and through which a vertically directed and oscillatable support for a single flat rectangular applicator is adapted to tiltingly move, and means to oscillate said applicator axially of the length of said couch-like structure whereby zonular areas of the body may be massaged by mechanical manipulation in a substantially horizontal plane.”

The District Court made no ruling as to infringement of this claim, contenting itself with its finding of invalidity.

The evidence shows that Lawrence Mack, President of defendant, prior to the alleged infringement, was a holder of Stauffer franchises [R. 127] and in fact was manager in Chicago, Illinois, of Stauffer's personally owned salons [R. 128]. This association ended in litigation which was terminated by mutual releases January 25, 1953 [Pltf. Ex. 15].

The gist of the lower Court's decision is:

“Now, this art is a simple art, and the court feels that it is so simple that the structure which has been developed here by Mr. Stauffer is a structure which could reasonably be expected to have been developed by one having ordinary skill in that art and that it just does not rise to the level of invention, as invention is protected by the patent laws.” [R. 380-381.]

It is appellant's contention that this is erroneous, and that far from mitigating against invention under the patent laws of this country, “Simplicity is the highest trait of genius.”

### Specification of Errors.

The errors relied upon and urged in the appeal are as follows :

“I.

“The District Court erred in finding that Claim 1 of said Letters Patent No. 2,240,679 in suit defines an assemblage of elements all of which were old in the prior art in which they operated in substantially the same way to produce substantially the same result, and such subject matter as a whole would have been obvious to and could have been produced by any person having ordinary skill in the art to which said subject matter pertains.

“II.

“The District Court erred in finding that Claim 1 of said Letters Patent No. 2,240,679 is wanting in invention.

“III.

“The District Court erred in failing to find that Claim 1 of Letters Patent No. 2,240,679 is infringed by defendant by the use of tables by defendant exemplified by plaintiffs Exhibits 16 and 17.

“IV.

“The District Court erred in concluding that Claim 1 of said Letters Patent No. 2,240,679 is invalid and void in law for lack of invention.

“V.

“The District Court erred in concluding that the defendant, Slenderella Systems of California, Inc., is entitled to judgment against the plaintiff, Bernard H. Stauffer, dismissing the complaint with prejudice.

“VI.

“The District Court erred in concluding that the defendant, Slenderella Systems of California, Inc., is entitled to judgment on its first counterclaim herein for declaratory relief, adjudging claim 1 of said Letters Patent No. 2,240,679 in suit invalid and void.

“VII.

“The District Court erred in failing to conclude that Claim 1 of Letters Patent No. 2,240,679 is valid.

“VIII.

“The District Court erred in failing to conclude that Claim 1 of Letters Patent No. 2,240,679 is infringed by defendant by the use of tables by defendant exemplified by plaintiff’s Exhibits 16 and 17.

“IX.

“The District Court erred in ordering, adjudging and decreeing that Claim 1 of United States Letters Patent No. 2,240,679 is invalid and void in law.

“X.

“The District Court erred in dismissing the complaint and ordering that the plaintiff shall take nothing by his complaint herein.

“XI.

“The District Court erred in ordering, adjudging and decreeing that the First Counterclaim for declaratory relief adjudging Claim 1 of United States Letters Patent No. 2,240,679 invalid and void is hereby sustained.

“XII.

“The District Court erred in failing to adjudge that Claim 1 of Letters Patent No. 2,240,679 is valid and infringed by defendant.”

### Summary of Argument.

The District Court erred in concluding that the Stauffer device is too simple to be an invention.

Simplicity does not mitigate against invention as is shown by an unbroken line of cases beginning with United States Patent No. 68, *Ryan v. Goodwin*, Fed. Cas. 12186, and including the Design Patent for a license plate holder upheld by this Court April 5, 1957, *Robert W. Brown & Co., Inc. v. De Bell*, 113 U. S. P. Q. 172, in all of which extremely simple devices were found to be inventions.

The District Court erred in failing to apply the rule that where the purpose and result of the patented device are different, very slight structural changes over the prior art may be enough to support a patent.

The District Court erred in failing to find that having created a wholly new system of passive exercise, inherent in the use of the patented device, which system has swept over the entire country, the patent should be supported because of the merit of what it does.

The District Court erred in failing to find infringement of Claim 1. Each and every element of claim 1 is found in the accused devices performing the identical functions.



## ARGUMENT.

### The District Court Erred in Concluding That the Stauffer Device Is Too Simple to Be an Invention.

The District Court did not find that the patented device was anticipated by the prior art, or did not involve invention over the prior art. It rejected the prior art [R. 380]. It simply found the patented device too simple to be an invention. This is error.

That simplicity does not mitigate against invention under the patent laws of the United States is one of the most clearly settled doctrines of that law.

We may ask, is the Stauffer device more simple than: ordinary barbed wire, *The Barbed Wire Patent*, 143 U. S. 293; or the one-piece metal collar button, *Krementz v. S. Cottle Co.*, 148 U. S. 556; or the cotton belt sustained in *Gandy v. Main Belting Co.*, 143 U. S. 587; or the clay pulverizer (a cylinder with longitudinal bars), *Potts v. Creager*, 155 U. S. 597; or the round-headed nail conventionally driven in chair legs in place of castors, *Barry v. Harpoon Castor Mfg. Co.*, 209 Fed. 207 (2 Cir.); or the idea of letting envelopes seal themselves under their own weight when stacked, *Postage Meter Co. v. Standard Mailing Machine Co.*, 9 F. 2d 19 (1 Cir.); or the method of printing motion picture titles sustained in *Lane v. Craftsmen Film Laboratories*, 7 F. 2d 288 (2 Cir.); or the wooden steering wheel, *Inland Mfg. Co. v. American Wood Rim Co.*, 14 F. 2d 657 (6 Cir.); or the well-known lady's hat box, *Brick v. A. I. Namm & Sons*, 22 F. 2d 693, affirmed *Per Curiam*, 22 F. 2d 697 (2 Cir.); or the ear tag for cattle, *Jensen-Salsbery Laboratories v. Salt Lake Stamp Co.*, 28 F. 2d 99 (8 Cir.); or making one arm of an old machine out of aluminum rather than cast

iron, *United Shoe Machinery Corp. v. E. A. Ferree Co.*, 64 F. 2d 101 (2 Cir.); or a stocking protector consisting of two pieces of leather sewed together at an angle, *Silver-Brown Co. v. Sheridan*, 71 F. 2d 935 (1 Cir.); or the conical hole in a picker stick of a loom to keep the nose of the shuttle from hitting bottom, *McKee v. Graton & Knight Co.*, 87 F. 2d 262 (4 Cir.); or attaching an arm in an electric clock so that it is magnetically held up by the motor, but drops into view on a current failure, *Warren Telechron Co. v. Waltham Watch Co.*, 91 F. 2d 472 (1 Cir.); or substituting a bourdon tube for a lever, *Baldwin-Southwark Corp. v. Tinius Olsen Testing Mach. Co.*, 88 F. 2d 910 (3 Cir.); or the match of United States Patent No. 68, covering a combination of phosphorus, chalk and glue, concerning which Mr. Justice Story charged a jury "The Combination is apparently very simple; but the simplicity of an invention, so far from being an objection to it, may constitute its great excellence and value," *Ryan v. Goodwin*, Fed. Cas. 12186, or the license plate frame this Court sustained in *Robert W. Brown & Co. v. De Bell*, 113 U. S. P. Q. 172, April 5, 1957?

Each of the cases cited above unequivocally holds that simplicity does not mitigate against invention, and this Court has announced that "It is quite apparent that simplicity alone will not preclude invention," *Patterson-Bal-lagh Corp. v. Moss*, 201 F. 2d 403 (9 Cir.).

Indeed, many cases have taken the view that "To obtain simplicity is the highest trait of genius," *Aronson v. Toy Devices, Inc.*, 1 F. 2d 91 at 92 (3 Cir.).

It seems abundantly clear that the District Court was not following the law when it held that the Stauffer device was just too simple to be an invention.

The District Court Erred in Failing to Apply the Rule That Where the Purpose and Result Are Different, Very Slight Structural Changes Over the Prior Art Are Enough to Sustain a Patent.

The patent in suit discloses a mechanism which when used as intended imparts passive exercise to the human body. Mr. Stauffer described this as follows:

“The Witness: The applicator that is carrying the weight induces a traction effect on the part of the body that is stationary. The weight of the body carried by the applicator causes a stretching effect between those areas of the body that are stationary, carried by the couch.

“And it is between this action and this weight of the body, carried on the couch, that you get the stretching effect or the traction in the various muscle areas.”

No prior art apparatus which functions in this way or achieves this result has been produced.

Perhaps, by modification, the Miller device, Exhibit D-1 [R. 451], could be made to so function, but this is immaterial. As said in the very oft cited case of *Topliff v. Topliff*, 145 U. S. 156, 36 L. Ed. 661:

“\* \* \* While it is possible that the Stringfellow and Surles patent might, by a slight modification, be made to perform the function of equalizing the springs which it was the object of the Augur patent to secure, that was evidently not in the mind of the patentees, and the patent is inoperative for that purpose. Their device evidently approached very near the idea of an equalizer; but this idea did not apparently dawn upon them, nor was there anything in their patent which would have suggested it to a

mechanic of ordinary intelligence, unless he were examining it for that purpose. It is not sufficient to constitute an anticipation that the device relied upon might, by modification, be made to accomplish the function performed by the patent in question, if it were not designed by its maker, nor adapted, nor actually used, for the performance of such functions.”

Another expression of the rule was made by Judge Learned Hand in *Traitel Marble Co. v. U. T. Hungerford Brass & Copper Co.*, 18 F. 2d 66, at 68 (2 Cir.), cert. den. 274 U. S. 753:

“\* \* \* If the thing itself be new, very slight structural changes may be enough to support a patent, when they presuppose a use not discoverable without inventive imagination. We are to judge such devices, not by the mere innovation in their form or material, but by the purpose which dictated them and discovered their function.”

Recently this Court stated in *Pointer v. Six Wheel Corporation*, 177 F. 2d 153 (9 Cir.) at 160-161:

“A test which has been found very useful and generally followed is that adverted to by Mr. Chief Justice Taft in the case just referred to,—namely, the discovery of the source of the difficulty and the application of a remedy not thought of before.” (Citing cases.)

\* \* \* \* \*

“Of course, if in solving the difficulty, the inventor merely does what would have been manifest to one skilled in the art, merely substitutes an obvious element for another, or recombines old elements, there is no invention.” (Citing cases.)

\* \* \* \* \*

“By the same token, invention cannot be defeated merely by showing that, in one form or another, each element was known or used before.” (Citing cases.)

\* \* \* \* \*

“The question is: Did anyone before think of combining them in this manner in order to achieve the particular unitary result,—a new function? *If not, there is invention.*” (Citing cases.)

\* \* \* \* \*

“At times, the result is accomplished by means which seem simple afterwards. But, although the improvement be slight, there is invention, unless the means were plainly indicated by the prior art. \* \* \*” (Citing cases.)

The Stauffer invention meets these tests. While it seemed simple afterwards to the District Court, it performed a new function and achieved a new result. These are the indicia of invention.

It would unduly extend this argument to continue citing other instances where this and other courts have similarly applied these rules, so it should suffice to summarize that the Stauffer invention is new as recognized by the District Court [R. 380]. It functioned in a new manner, *i.e.*, as explained by Mr. Stauffer, *supra*, and achieved a new result, passive exercise. Invention is thus demonstrated.

We believe that this is a clear case, but if we are wrong, and it is a close case, then the Court should give weight to the phenomenal commercial success of the Stauffer System, based upon the invention of the patent in suit and of the Slenderella System, based upon defendant's infringement.



Starting with one salon in Los Angeles in 1938, the Stauffer System expanded rapidly until in 1946, they had 200 salons spread across the nation [R. 99-100]. The Stauffer System embodies use of the patented invention [R. 102-103].

We shall demonstrate *infra* that the tables used in the Slenderella System are not only infringements of the patent in suit but were copied from Stauffer tables by Lawrence Mack, a once trusted employee of the plaintiff. Slenderella System is international. We thus have a case where the plaintiff utilizing his invention and the defendant pirating it have both enjoyed phenomenal commercial success, which, under the well-known rule, is enough to resolve the question of invention in favor of plaintiff in a close case.

*Research Products v. Tretolite Co.*, 106 F. 2d 530 (9 Cir.);

*Pointer v. Six Wheel*, 177 F. 2d 153 (9 Cir.);

*Stebler v. Riverside Heights Orange Growers' Association*, 205 Fed. 735 (9 Cir.);

*Smith v. The Dental Vulcanite Co.*, 93 U. S. 486.

Finally, though defendant denies that the Stauffer device is an invention, it imitates it—why? We think the language of the court in *Kurtz v. Belle Hat Lining Co.*, 280 Fed. 277, 281 (2 Cir.), most apt:

“The imitation of a thing patented by a defendant, who denies invention has often been regarded, perhaps especially in this Circuit, as conclusive evidence of what the defendant thinks of the patent, and persuasive of what the rest of the world ought to think.”

The District Court Erred in Failing to Find  
Infringement of Claim 1.

Each and every element of Claim 1 is present in the accused devices exactly as it is present in the patented invention. The accused structures are depicted in the drawings, Exhibits 16 and 17 and the Kinematic models thereof, Exhibits 18 and 19.

Exhibit 17 differs from Exhibit 16 only in minor points as stated by defendant's expert, Dr. Knapp [R. 218]. This witness applied numbers to the various parts of Exhibit 16, and using those, Claim 1 is applied to Exhibit 16 as follows:

CLAIM 1.

A muscle relaxing machine comprising a couch-like structure for repose of the human body

in the top surface of which a slot-way is formed

and through which a vertically directed and oscillatable support

for a single flat rectangular applicator

is adapted to tiltingly move

EXHIBIT 16.

The couch is given no number, but view I is a side view of the couch [R. 208]

There obviously has to be an opening in which the arms and pads can move

arms 11, 11A

pads 10

arms 11 pivot or tilt about bearing 12

CLAIM 1.

and means to oscillate said applicator axially of the length of said couch-like structure whereby sonular areas of the body may be massaged by mechanical manipulation in a substantial horizontal plane.

EXHIBIT 16.

connecting rod 17 and cam 21 are driven by a motor and pulley [R. 215] to oscillate the arms 11, 11A in planes extending longitudinally of the couch.

Infringement is thus clearly established. Indeed, defendant has used little imagination but uses the very same mechanical elements as plaintiff, *i.e.*, motors, pulleys, cams, pitmans, pivoted arms and substantially horizontal applicators.

Nor is this surprising when we recall that defendant's President, Lawrence Mack, learned this business as a franchise holder and salon manager of plaintiff. He merely copied what he had been furnished by plaintiff, and he did this while he was still managing Stauffer's Chicago operations [R. 128-129].

This is a clear case of deliberate, wilful infringement.

**Conclusion.**

In conclusion it is respectfully submitted that the sole basis for the District Court's decision, *i.e.*, that the apparatus of the patent in suit is too simple to be an invention, involves a basic error in law and must be reversed. The patent in suit discloses a device which functions in a new way to achieve a new result, the manipulating of a zonular area of the human body against the weight of the remainder of the body supported on a couch to thus achieve passive exercise. That under such circumstances,

the invention may lie in the discovery of the idea and that very slight structural differences from the prior art are enough to sustain the patent and that it is immaterial that by modification the prior art might be made to perform this function where the prior art was not designed, adapted or used to perform such function.

That the patent in suit has enjoyed a remarkable commercial success, not only in the form commercialized by the plaintiff but in the form pirated by the defendant, which should be enough to resolve any lingering doubts as to invention.

Finally, Claim 1 of the patent in suit is clearly applicable to the accused device and the infringement in this case has been flagrant, willful and deliberate. Accordingly, this Court should enter a decree reversing the District Court and ordering judgment in favor of the plaintiff that Claim 1 of the patent in suit is valid and has been infringed by the defendant.

LYON & LYON,  
CHARLES G. LYON,  
*Attorneys for Plaintiff-Appellant.*





No. 15,418.

IN THE

# United States Court of Appeals

FOR THE NINTH CIRCUIT

---

BERNARD H. STAUFFER,

*Appellant,*

*vs.*

SLENDERELLA SYSTEMS OF CALIFORNIA, INC.,

*Appellee.*

---

## APPELLEE'S BRIEF.

---

HARRIS, KIECH, FOSTER & HARRIS,  
FORD HARRIS, JR.,

321 Subway Terminal Bldg.,  
417 South Hill Street,  
Los Angeles 13, California,

NEWLIN, TACKABURY & JOHNSTON,  
HUDSON B. COX,

1100 Roosevelt Building,  
727 West Seventh Street,  
Los Angeles 17, California,

*Attorneys for Appellee.*

**FILED**

JUN 19 1957

PAUL P. O'BRIEN, CLERK



## TOPICAL INDEX

PAGE

### I.

Introduction .....	1
--------------------	---

### II.

Statement of the case.....	2
(a) The parties .....	2
(b) The issues .....	2
(c) The Stauffer patent in suit—generally.....	3
(d) Detailed construction and operation of Stauffer patent machine .....	4
(e) The file-wrapper history of the Stauffer patent.....	7
(f) The Stauffer patent as a mere paper patent.....	10
(g) The defendant's accused machines.....	10
(h) The prior art—generally.....	12

### III.

Summary of argument.....	15
--------------------------	----

### IV.

Argument .....	16
A. Appellant's opening brief does not comply with the rules and the appeal should be summarily dismissed.....	16
B. Appellant's opening brief wholly misconstrues the judg- ment below .....	17
C. The District Court's findings of fact, conclusions of law, and judgment that claim 1 is invalid for lack of invention are amply supported by the evidence and should be sus- tained .....	18
D. Infringement is not an issue before the court on this appeal .....	24

E. Defendant's machines do not infringe claim 1 of the Stauffer patent in suit.....	26
1. Defendant's machines do not include certain of the important elements of claim 1 and thereby do not infringe .....	27
2. Defendant's machines do not have the same mode of operation as that of the Stauffer patent.....	30
3. Defendant's machines do not produce the alleged results of the machine of the Stauffer patent.....	33

## V.

Conclusion .....	35
------------------	----

## TABLE OF AUTHORITIES CITED

CASES	PAGE
A. & P. Tea Co. v. Supermarket Corp., 340 U. S. 147.....	23
Aeration Processes, Inc. v. Lange, 196 F. 2d 981.....	31
Air Device v. Air Factors, 210 F. 2d 481.....	26
Burgess Battery Co. v. Coast Insulating Corp., 114 F. 2d 779....	26, 29
.....	26, 29
Craftint Mfg. Co. v. Baker, 94 F. 2d 369.....	26
Grant v. Koppl, 99 F. 2d 106.....	27
Helbush v. Finkle, 170 F. 2d 41.....	25
Himes v. Chadwick, 199 F. 2d 100.....	22
I. T. S. Rubber Co. v. Essex Rubber Co., 272 U. S. 429, 47 S. Ct. 136, 71 L. Ed. 335.....	28
Kemart Corp. v. Printing Arts Research Laboratories, 201 F. 2d 624 .....	27
Kwikset Locks, Inc. v. Hillgren, 210 F. 2d 483.....	22, 23
Lincoln v. Waterbury Button Co., 291 Fed. 594.....	31
O'Leary v. Liggett Drug Co., 150 F. 2d 656.....	26
Oriental Foods, Inc. v. Chun King Sales, Inc., ..... F. 2d ....., 113 U. S. P. Q. 404.....	23, 24
Ruud Mfg. Co. v. Long-Landreth-Schneider Co., 250 Fed. 860....	31
Scriber-Schroth Co. v. Cleveland Trust Co., 311 U. S. 211, 61 S. Ct. 235, 85 L. Ed. 132.....	28
Smith v. Magic City Kennel Club, Inc., 282 U. S. 784, 51 S. Ct. 291, 75 L. Ed. 707.....	28
Stearns v. Tinker & Razor, 220 F. 2d 49.....	26

### RULES

Federal Rules of Civil Procedure, Rule 52(a).....	17
Rules of the United States Court of Appeals, Ninth Circuit, Rule 18(d) .....	17

### STATUTES

United States Code, Title 35, Sec. 102.....	23
United States Code, Title 35, Sec. 103.....	23





No. 15,418.

IN THE

# United States Court of Appeals

FOR THE NINTH CIRCUIT

---

BERNARD H. STAUFFER,

*Appellant,*

*vs.*

SLENDERELLA SYSTEMS OF CALIFORNIA, INC.,

*Appellee.*

---

## APPELLEE'S BRIEF.

---

### I.

### INTRODUCTION.

This is appellee's answer to "Appellant's Opening Brief" on file in the above-entitled action.

For brevity, plaintiff's exhibits are sometimes referred to as "PX" followed by the number of the exhibit (*e. g.*, "PX-1"), and defendant's exhibits are referred to as "DX" followed by the designating letter (*e. g.*, "DX-A"). All emphasis is ours unless otherwise noted. Appellant Bernard H. Stauffer is referred to hereinafter as plaintiff or "Stauffer," and appellee is referred to as defendant or "Slenderella."

## II. STATEMENT OF THE CASE.

### (a) The Parties.

The plaintiff Stauffer is the owner of the Stauffer patent No. 2,240,679 in suit [Finding 4, R. 48], and is a partner in a business enterprise known as "Stauffer System" which operates or franchises salons providing reducing treatments for women [R. 98-100].

The defendant Slenderella Systems of California, Inc. is a California corporation operating in Los Angeles, California [Finding 2, R. 48]. It is a mere user of couches or "tables," as they are termed in the record, charged by Stauffer to infringe his patent in suit. The defendant does not manufacture or sell such tables.

### (b) The Issues.

Although the Stauffer patent No. 2,240,679 in suit contains two claims, only claim 1 is involved here, the plaintiff at the trial having withdrawn his charge of infringement as to claim 2 [R. 73].

Having held claim 1 of the Stauffer patent in suit invalid, the District Court entered no findings of fact or conclusions of law as to its infringement by defendant's accused devices [R. 381]. Thus, the only issue presented by this appeal is as follows:

- (1) Is the judgment of the District Court, holding claim 1 of Stauffer patent No. 2,240,679 in suit invalid in law, supported by the evidence?

Appellant's Opening Brief [pp. 13-14] argues the issue of infringement and we completely answer this argument hereinafter, showing clearly that there is no infringement

of claim 1 of the Stauffer patent in suit. However, this issue was not determined by the District Court and is not a proper issue before this Court on this appeal.

**(c) The Stauffer Patent in Suit—Generally.**

The Stauffer patent No. 2,240,679 in suit [R. 392] is entitled "Muscle Relaxing Machine," and purportedly relates to "*mechanical means* to soothe, relax, and strengthen certain of the muscular areas of the human body . . . by *massage* of certain of the muscles of the spinal tract [p. 1, Column 1, lines 15-21]." In short, it is a mechanical means for massaging the human body.

The Stauffer patent in suit discloses a couch or "table" 10 upon which a user 12 lies, with the oscillatable "seat," applicator, or paddle 18 engaging the portion of the body to be massaged. The seat 18 is carried on a pair of upright supports 20 which are rotated together through arcs on pivots 21 by pitman rods 28 which are moved back and forth by cams, linkage, and pulleys driven by an electric motor 50. The detailed construction of the machine of the Stauffer patent is fully described in the record by Dr. Knapp [R. 200-205]. The only portion of the detailed construction of the Stauffer patent device that requires any consideration in this case is the movable applicator 18, its supports 20, and the nature of their movement. The other mechanical details are of no importance.

Couches or tables for providing mechanical massage to the human body were old in the art long prior to the Stauffer patent. As early as 1869, a patent issued to Taylor, No. 86,604 [R. 470] on a generally similar type of machine. Generally similar devices are shown in the patents to: Hardy *et al.*, No. 1,276,526 [R. 473], issued in 1918; Hardy, No. 1,391,893 [R. 477], issued in 1921;

Parker, No. 1,978,223 [R. 446], and Miller, No. 1,953,424 [R. 451], issued in 1934, and Hardy, No. 1,999,412 [R. 496], issued in 1935.

**(d) Detailed Construction and Operation of Stauffer Patent Machine.**

In the machine of the Stauffer patent in suit, the seat or applicator 18 and its supports 20 move between their full line and dotted line positions as shown in Fig. 2 of the patent drawing [R. 392], being so noted in the specification [R. 395, Col. 1, lines 63-68]. In both the full line and dotted line limit positions, the support 20 is on the same side of the vertical and the seat 18 is tilted with respect to the horizontal. Thus, it will be understood, *the seat or applicator 18 pivots through a small arc on one side only of an imaginary vertical line through the supporting pivot 21.* This specific limited movement is clearly described in the Stauffer patent specification as follows:

“The legs 20 as will be noted in the drawings are inclined toward the head A of the couch, the degree of inclination being relatively small, being of a probable maximum of 15 degrees from the vertical when in extreme forward position and approximately 5 degrees from the vertical when in the other extreme end stroke position. This arrangement causes the seat 18 to lie at a constant although variable angle with respect to the upper surface of the couch [R. 394, Col. 2, line 54, to R. 395, Col. 1, line 8].”

“. . . the degree of movement ranges from about minus 15 to minus 5 degrees from the vertical, thereby causing the manipulator to swing through a range of 10 degrees, during which interval the seat or manipulator support 20 at no time passes the vertical, hence movement imparted to a body lying thereon is



accentuated in that its greatest thrust or lift is in one direction only, the return movement being a lowering and receding movement as distinguished from a positive upward and forward lift . . . [R. 395, Col. 1, line 75, to Col. 2, line 11].”

“The machine of this invention is adapted to gently, yet forcibly lift the body in a direction toward the head of the user, a distance of approximately two (2) inches, and then to return the body to the point of beginning . . . [R. 395, Col. 2, lines 64-69].”

This limited movement of the supports 20 and its importance in the patent in suit was admitted by the patentee Stauffer at the trial as follows [R. 146-147]:

“Q. (By Mr. Harris): You are familiar with the fact, are you not, that in your patent in the drawing and in the specification of the patent there is described a device in which the support 20 moves only on one side of the vertical, through a small arc of about ten degrees, from about minus fifteen degrees to minus five degrees from the vertical?

“A. Yes, sir, I am familiar with it.

“Q. So far as your patent is concerned—we are not speaking now about your commercial machines in any way—but so far as your patent is concerned, that small arc of movement is a very important factor, is it not?

“A. It is, yes, sir.

“Q. And the purpose in the device described in the specification and illustrated in the drawings of your patent in suit, the purpose in limiting the travel of the seat 18 to an arc, which is on one side of the vertical, is to establish a better motion of the seat as it is applied to the human anatomy, is it not?

“A. That is correct, yes, sir.

“Q. As a matter of fact, Mr. Stauffer, you regard that motion applied through the travel of the seat, in your patent in suit, as it is applied to the body? In other words, that motion to and fro, running through that degree of angle we referred to, has the essential factors or features of your patent in suit, does it not?

“A. I would consider it important in the treatment process, yes, sir.

“Q. But you do consider it as the essential factor in your patent in suit, do you not?

“A. Well, I would say one of them.”

The limited motion of the supports and applicator of the Stauffer patent in suit was fully confirmed by the expert Dr. Knapp [R. 206-208], who pointed out that the movement of the support in the patent in suit is quicker in one direction than in the other [R. 204-205], and does not operate in simple harmonic motion [R. 228-229]. As will be shown hereinafter, this in itself distinguishes the table of the Stauffer patent in suit from defendant's accused tables.

As pointed out by plaintiff Stauffer at the trial, *the speed* of oscillation of the seat or “paddle” 18 of his patent in suit *is critical*, the preferred speed being 130 cycles per minute but being variable 30 cycles per minute above or below the preferred speed [R. 148]. It is to be noted that, although Stauffer admits such speed of oscillation to be critical, his patent in suit does not even mention this factor [R. 149]. In any event, this speed factor of the device of the Stauffer patent in suit also distinguishes it from defendant's accused tables in which the pads oscillate at a rate of about 186 cycles per minute [R. 227].

With the machine of the Stauffer patent in suit, the plaintiff-patentee claims that its operation effects a stretching effect on the muscles of a body thereon [R. 94-95], whereas the evidence shows that defendant's accused tables do not effect any stretching of the muscles [R. 311].

**(e) The File-wrapper History of the Stauffer Patent.**

In determining the metes and bounds of the claim and the nature of the alleged invention of the Stauffer patent, it is important to note the file-wrapper history of the patent application through the Patent Office. Such file-wrapper and its contents appear as Defendant's Exhibit B-1 [R. 399-441].

Sheet 1 of the original drawings [R. 412] filed with the original application for the Stauffer patent in suit was *quite different* from the corresponding sheet 1 of the drawings appearing in the issued patent [R. 392], a reproduction of the original application drawing being attached at the end of this Brief as "Plate I" and a reproduction of the corresponding drawing of the issued patent as "Plate II," for the convenience of the Court in comparing the two drawings.

In the original patent application drawing, Plate I, Fig. 2 in dotted lines shows the limits of movement of the seat 18 and its supports 20 [R. 405, lines 27-28], the left-hand dotted line limit position being to the left of the vertical and the right-hand dotted line limit position being on the right of the vertical. The supports 20 are shown in full lines in vertical position in Figs. 2 and 3 of the original drawing and the flat top of the seat 18 is shown in Fig. 2 in full lines as horizontal and parallel with the top of the couch.

Application claims 2, 3, 4, 5 and 6 [R. 408-409] as originally presented with the application for the Stauffer patent, were specifically limited to a construction in which the "body contacting member" [or seat 18] extended "in a plane horizontal with the top surface" of the couch.

The foregoing makes it abundantly clear that the Stauffer patent application as originally filed disclosed and claimed a machine in which the top of the applicator or "seat" 18 in its central position was horizontal and parallel with the top of the couch, but movable through a small arc from a tilted position on one side to a reversed tilted position on the other side of the central position.

The original claims were all rejected by the Patent Office as unpatentable over the prior art [R. 414].

The applicant Stauffer, through his attorney, then changed his drawing from the form shown in Plate I to that shown in Plate II, substantially limited his specification by amendment to specify in effect that all movement of his supports 20 is on only one side of the vertical, and amended his claims 1 and 5 to make it clear that the support 20 is always on one side of the vertical and that the seat 18 is "constantly inclined from the horizontal" [R. 415-419]. In making these amendments, Stauffer's attorney stated that such amendments to the specification "set forth the novelty of the invention [R. 419, lines 3-5]," and attempted to distinguish the claims from the prior art patents by the allegation that the Stauffer machine lifted the body more pronouncedly in one direction than in the other [R. 419, lines 9-11 and 19-26]. These amendments and remarks make it clear that if there is any invention in the machine shown in the Stauffer patent (which we deny) it is limited very particularly to a construction in which the seat or applicator 18 is always tilted [*i. e.*

“adapted to tiltingly move”] with respect to the horizontal and in which the supports 20 are always on only one side of the vertical.

The applicant Stauffer finally on January 25, 1940, presented to the Patent Office claim 10 of his application [R. 421], which is generally similar to claim 1 of the Stauffer patent in suit but broader. Such application claim 10 was then rejected by the Patent Office as unpatentable over the prior art [R. 424]. The applicant Stauffer then amended his application claim 10 to limit it to a construction in which there is only a “single” flat applicator which is “tiltingly” moved [R. 426], which amendments appear in long-hand on the face of claim 10 as originally presented [R. 421], a copy of such page of the file-wrapper of the Stauffer patent application being attached as “Plate III” hereto. As so limited by the applicant, claim 10 was allowed [R. 428], and as so amended appears as claim 1 of the Stauffer patent in suit.

It will thus be apparent that Stauffer started out with an application disclosing and claiming one type of machine, and then, through amendments to his drawing, specification, and claims wound up disclosing and asserting invention for something quite different. It is apparent from the record discussed above that Stauffer’s claim 10, as originally presented to the Patent Office and as shown without the interlineations on Plate III, was considered by the Examiner as unpatentable, the rejection was acquiesced in by the applicant Stauffer, and the claim was amended in two important respects [*i. e.*, “single” and “tiltingly”] as shown by such interlineations on Plate III.

It is defendant’s contention, of course, that claim 1 of the Stauffer patent in suit is so limited by the file-wrapper history that it is not conceivably infringed by defendant.



**(f) The Stauffer Patent as a Mere Paper Patent.**

If claim 1 of the Stauffer patent in suit is narrowly interpreted as indicated above, the patent is a mere paper patent and has enjoyed no commercial success whatever because the tables actually used and leased by plaintiff Stauffer have not been covered by the patent.

Plaintiff Stauffer candidly admitted that in all, except the first few, tables made by him the supports 20 for the applicator 18 have moved through an arc from one side of the vertical to the other side of the vertical and back [R. 142, 145-147]. This is the type of motion exemplified by the Stauffer "Home Unit" table in evidence as physical Exhibit 2 [R. 79]. It is the type of movement illustrated by the original drawing in the Stauffer patent application [Plate I, *infra*], which was later changed to indicate movement on only one side of the vertical [Plate II, *infra*].

Thus, it is defendant's contention that the commercial machine used by Stauffer is not covered by his patent and that the machine of the Stauffer patent has had no commercial success whatever.

**(g) The Defendant's Accused Machines.**

The defendant does not make or sell any machines, being a mere user of two slightly different types of accused machines [R. 166-167].

The drawings Exhibits 16 and 17 (physical exhibits) illustrate the two types of tables used by the defendant [R. 166-167]. The table shown in Exhibit 17 is substantially the same as that shown in Exhibit 16, with minor immaterial differences [R. 218-220]. The construction of defendant's table shown in Exhibit 16 was explained in detail by the expert witness Dr. Knapp [R. 208-215]. We

believe that following is a fair summary of Dr. Knapp's uncontroverted testimony as to the construction of both of defendant's tables.

The Slenderella table has a vertical steel framework rigidly supported on a base which rests on the floor. Above the framework is a horizontal table top which is supported on rocker arms 24 and 25 [PX-16] for oscillatory horizontal movement of the entire table top relative to the framework and base. Suitable mechanism is provided for providing such oscillatory movement of the table top as desired.

Extending up through a pair of parallel slots in the table top are a pair of generally vertical rocker arms 11 and 11A [PX-16], upon the top of each of which is a pair of pads 10. Such rocker arms are pivoted at their lower ends in bearings 19 carried by supports 13 which are fixed to and hang down from the oscillatable table top. By suitable pitmen, eccentrics, cams, motor, etc., the rocker arms may be oscillated independently or together to cause the pads on their upper ends to oscillate back and forth.

The general type of movement of the pads or applicators in defendant's tables is illustrated by the full scale drawing, defendant's Exhibit C (a physical exhibit), although the actual arc of movement in defendant's tables is less than that shown in this drawing [R. 222-224]. As will be noted, the supports for the pads in defendant's tables move through a short arc from a position on one side of the vertical to a position on the other side of the vertical, and back again. This movement is "simple harmonic" motion, whereas in the table of the Stauffer patent in suit the motion is quite different in that it is faster on one-half of the cycle than on the other one-half [R. 228-229].

In defendant's accused tables the pads are oscillated back and forth at a rate of about 186 oscillations per minute [R. 227], whereas in the device of the Stauffer patent the range of rate of movement is between 100 and 160 oscillations per minute [R. 148].

**(h) The Prior Art—Generally.**

The prior art patents primarily relied upon by defendant to establish the invalidity of the Stauffer patent in suit are the patents to Parker, No. 1,978,223 [R. 446]; Miller, No. 1,953,424 [R. 451], and Gunderman, No. 1,825,588 [R. 462]. The other prior art patents of record [R. 470-503] are included in the record to show what was before the Patent Office in considering the application for the Stauffer patent in suit and to show the general state of the prior art.

Elaborate working models of the pertinent operating mechanism of the Parker, Miller, and Gunderman patents are in the record as physical exhibits which will be helpful to the Court in understanding the operation of the prior art devices of these patents. Thus, physical Exhibit E is a photostatic enlargement of sheet four of the drawings of the Gunderman patent No. 1,825,588 [R. 464], and physical Exhibit F is a lucite model of the operating mechanism [R. 233]. Similarly, Exhibit G is an enlargement of sheet 3 of the drawings of the Miller patent No. 1,953,424 [R. 453], and Exhibit H is a lucite model of its operating mechanism [R. 243]. Exhibit I is a photostatic enlargement of sheet 1 of the drawings of the Parker patent No. 1,978,223 [R. 446], and Exhibit J is a lucite model of the operating mechanism thereof [R. 251-252].

By superimposing the lucite models over their respective photostats and indexing the operating models in the

correct position by means of the indexing buttons on the enlargements, the operating models can readily be operated by hand to demonstrate the actual operation of the devices shown in the prior art patents. Using this method, the expert Dr. Knapp demonstrated to the trial court the operation of the mechanism of the Gunderman patent [R. 233-235], of the Miller patent [R. 243-246], and the Parker patent [R. 252-253].

The detailed construction and operation of the devices of the prior art patents to Gunderman, Miller, and Parker was clearly and extensively explained by the expert witness Dr. Knapp [R. 230-255]. His testimony with regard thereto is summarized as follows:

Parker No. 1,978,223 [R. 446] shows a treatment table with an open slot 13a in its top (Fig. 1) through which extend six pairs of vertical supports 18 carrying curved body applicators 17 on their upper ends. All of the supports 18 are pivoted on pivots 36 near their lower ends and are connected to a pitman rod 27 which is reciprocated through a cam and eccentric 28 by a belt 30 driven by a motor 33. When the motor is operated, the supports 18 oscillate in simple harmonic motion on their pivots to move in a small arc from one side of the vertical to the other and back. The purpose of the device of the Parker patent is to provide mechanical means "to impart a massaging action to the muscles of the spinal processes" [R. 448, lines 8-10]. It is to be noted that the applicators of the Parker machine move from one side of the vertical through the vertical and on to the other side of the vertical, and then back, exactly as originally disclosed in the application for the Stauffer patent in suit [See: Section (e), above]. It was not until after Stauffer amended his specification and claims to limit his

movement to an arc on one side of the vertical that the Patent Office allowed him any claims.

The Miller patent No. 1,953,424 [R. 451, 453] shows a couch-like structure 20 for the therapeutic treatment of the human body, having a slot in its upper surface through which extends a support or arm having a pad 27 on its upper end, the arm being moved upwardly and longitudinally and back by a pitman rod 71 driven through suitable gearing by an electric motor 49. As stated in the Miller patent "The action thus produced is a comparatively slow pulsating movement at the rate of about 120 pulsations per minute [p. 3, lines 21-24]," which is within the same speed range of 100 to 160 cycles of the device of the Stauffer patent in suit [R. 148].

The Gunderman patent No. 1,825,588 [R. 462] shows a vibrating machine "having vibratory plates which may be used not only for the purpose of *massaging* and otherwise treating the feet but also susceptible of use in *manipulating* other parts of the body [p. 1, lines 21-25]." While no couch is shown in the Gunderman patent, it makes it plain that "the lower part of the body may be massaged or manipulated by the operator sitting on the plates, this massaging or manipulation increasing the circulation at this part of the body and in addition to exercising the muscles in the vicinity of the hips will also increase circulation of the blood and benefit the operator with respect to certain diseases, as piles [p. 2, lines 104-112]." The Gunderman patent in Figs. 1-5, inclusive [R. 462-464] shows a machine including *two* side-by-side oscillatable applicators 26 (as in defendant's accused machines). It also shows in Fig. 6 [R. 465] a *single* applicator 26 (as in the Stauffer patent in suit), the same being described in the specification [p. 2, lines 112-118].



The patents to Miller and Gunderman were not considered by the Patent Office in connection with the application for the Stauffer patent in suit, although the Parker patent was so considered.

### III.

#### SUMMARY OF ARGUMENT.

A. Appellant's Opening Brief does not comply with the rules and the appeal should be summarily dismissed.

B. Appellant's Opening Brief wholly misconstrues the judgment below.

C. The District Court's Findings of Fact, Conclusions of Law, and Judgment that claim 1 is invalid for lack of invention are amply supported by the evidence and should be sustained.

D. Infringement is not an issue before the Court on this appeal.

E. Defendant's machines do not infringe claim 1 of the Stauffer patent in suit.

1. Defendant's machines do not include certain of the important elements of claim 1 and thereby do not infringe;

2. Defendant's machines do not have the same mode of operation as that of the Stauffer patent device;

3. Defendant's machines do not produce the alleged results of the machine of the Stauffer patent.

IV.  
ARGUMENT.

A. Appellant's Opening Brief Does Not Comply With the Rules and the Appeal Should Be Summarily Dismissed.

The only findings of fact of the District Court charged by plaintiff to be erroneous are as follows:

"7. Claim 1 of said Letters Patent No. 2,240,679 in suit defines an assemblage of elements all of which were old in the prior art in which they operated in substantially the same way to produce substantially the same result, and such subject matter as a whole would have been obvious to and could have been produced by any person having ordinary skill in the art to which said subject matter pertains [R. 49]."

"8. Claim 1 of said Letters Patent No. 2,240,679 is wanting in invention [R. 49]."

The corresponding conclusions of law of the District Court charged by plaintiff to be erroneous are as follows:

"2. Claim 1 of said Letters Patent No. 2,240,679 in suit is invalid and void in law for lack of invention [R. 49]."

"3. The defendant, Slenderella Systems of California, Inc., is entitled to judgment against the plaintiff, Bernard H. Stauffer, dismissing the complaint with prejudice [R. 49]."

"4. The defendant, Slenderella Systems of California, Inc., is entitled to judgment on its first counterclaim herein for declaratory relief, adjudging claim 1 of said Letters Patent No. 2,240,679 in suit invalid and void [R. 50]."

Appellant's Opening Brief, although specifying the above findings of fact and conclusions of law to be erroneous in its Specification of Errors [pp. 4-5], makes no attempt whatever to show that such findings of fact by the District Court are erroneous, much less that they are clearly erroneous. Appellant's Opening Brief makes no attempt whatever to comply with Rule 18(d) of this Court which requires an appellant to state "as particularly as may be wherein the findings of fact and conclusions of law are alleged to be erroneous."

Rule 52(a) of the Rules of Civil Procedure provides:

“. . . Findings of fact shall not be set aside unless clearly erroneous. . . .”

Appellant's Opening Brief (p. 7) states: "The District Court *did not find* that the patent device was anticipated by the prior art, or *did not involve invention over the prior art.*" This statement in the Opening Brief, upon which appellant's entire argument is based, is obviously flatly wrong or highly misleading in view of the express Finding of Fact 7 and Conclusion of Law 2 quoted above.

We suggest that this appeal should be dismissed and the judgment of the Court below affirmed upon the ground that the Appellant's Opening Brief does not comply with the Rules.

## **B. Appellant's Opening Brief Wholly Misconstrues the Judgment Below.**

Appellant's Opening Brief, in the first section of its argument (pp. 7-8) entitled "The District Court Erred in Concluding That the Stauffer Device Is Too Simple to Be an Invention," states, with respect to the decision by the District Court: "It simply found the patented device too simple to be an invention (p. 7)" and ". . . the District

Court was not following the law when it held that the Stauffer device was just too simple to be an invention (p. 8).”

Even a perfunctory reading of the findings of fact, conclusions of law, and judgment below [R. 48-50] and the District Court’s brief oral opinion [R. 380-381] shows that the District Court neither concluded, found, nor held any such thing as attributed to it by Appellant’s Opening Brief. True, the District Court characterized the art in which the Stauffer patent is included as a *simple art*, but nowhere indicated that it was holding the Stauffer patent invalid merely because it is simple. On the contrary, the District Court held the Stauffer patent invalid for lack of invention because all of the elements of claim 1 were old in the prior art, and at best it was a mere matter of mechanical skill to put them together as Stauffer had done.

While we agree that the Stauffer patent shows and claims a ridiculously simple device, this was not the basis for the decision of the District Court and appellant’s argument with respect to simplicity is immaterial.

**C. The District Court’s Findings of Fact, Conclusions of Law, and Judgment That Claim 1 Is Invalid for Lack of Invention Are Amply Supported by the Evidence and Should Be Sustained.**

Finding of Fact 7 [R. 49] finds that claim 1 of the patent in suit: “. . . defines an assemblage of elements all of which were old in the prior art in which they operated in substantially the same way to produce substantially the same result. . . .” This finding of fact is amply supported by the evidence, as shown hereinafter.

Claim 1 of the Stauffer patent in suit is as follows:

“1. A muscle relaxing machine comprising a couch-like structure for repose of a human body in the top surface of which a slot-way is formed and through which a vertically directed and oscillatable support for a single flat rectangular applicator is adapted to tiltingly move, and means to oscillate said applicator axially of the length of said couch-like structure whereby zonular areas of the body may be massaged by mechanical manipulation in a substantially horizontal plane.”

Following we take each element of claim 1 of the Stauffer patent in suit (as a quoted subheading) and show where it appears in the prior art of record.

**“A muscle relaxing machine comprising a couch-like structure for repose of a human body. . . .”**

The Stauffer patent in suit makes it plain that such alleged muscle relaxation is accomplished by mechanical massage or manipulation of muscle areas of the body, stating:

“The machine of this invention relates to mechanical means to soothe, relax, and strengthen certain of the muscular areas of the human body . . . by massage of certain of the muscles of the spinal tract [R. 394, Col. 1, lines 15-21].”

Couch-like machines for the repose of a human body and which impart mechanical massage to zonal muscles or areas for the same general purpose are very old in the art.

The patent to Taylor No. 86,604 [R. 470] issued in 1869, shows such a couch-like machine, the effect of which “is soothing, laxative, and calculated to increase muscular action and development [p. 2, Col. 1].”



Similarly, the patent to Hardy No. 1,391,893 [R. 477], issued in 1921, shows such a couch-like machine having applicators which engage the body “so as to impart a rubbing motion over the surface of the body with which they contact, as nearly similar to the movement of the hand thereover as is possible with mechanical devices [p. 1, lines 50-54],” and which further states “The results of this *massaging operation* tend to set up the circulation in the vicinity of the spine and to thus energize the entire system, and the patient is *much invigorated and refreshed* [p. 1, lines 61-65].” To the same effect is the later patent to Hardy, No. 1,999,412 [R. 496].

Also, the patent to Parker No. 1,978,223 [R. 446] shows such a couch-like “Spinal Massage Apparatus,” adapted to “impart a massaging action to the muscles of the spinal processes [p. 1, lines 8-10].”

The patent to Miller No. 1,953,424 [R. 451] likewise shows such a couch-like structure.

**“ . . . in the top surface of which is a slot-way”**

Couch-like structures having such a “slot-way” are shown in the prior art patents to Parker [R. 446], Miller [R. 451, at 453], Taylor [R. 470], Hardy *et al.* [R. 473], Hardy '893 [R. 477], and Hardy '412 [R. 496].

**“ . . . a slot-way . . . through which a vertically directed and oscillatable support for a single flat rectangular applicator is adapted to tiltingly move. . . .”**

All of the foregoing prior art patents have vertically directed and oscillatable supports for an applicator.

In Parker [R. 446-447], they are the supports 18 which are vertically directed, extend through the slot-way 13a,

and oscillate about their pivots 36 from a position on one side of the vertical to a position on the other, and carry the applicators 17 on their upper ends.

Parker No. 1,978,223 shows multiple rounded applicators 17, not a *single flat rectangular* applicator as claimed in claim 1. A single applicator, however, is shown in each of the patents to Miller [R. 451] and Gunderman [Fig. 6, 465], neither of which were file-wrapper references considered by the Patent Office and none of the prior art before the Patent Office R. 470-503] showed a single applicator. The Miller patent, furthermore, shows an applicator pad 27 which is *flat* on top [See Fig. 4, R. 453].

It is plain, therefore, that no invention would be involved in merely using a single applicator in the Parker patent construction and making it flat on top.

In any event, if claim 1 of the Stauffer patent is limited to a single and flat applicator to save its validity, defendant's machines do not infringe because they use *four* applicators, none of which is flat on top, as will be developed hereinafter.

The other possible limitation in this quoted portion of claim 1 is that the "oscillatable support . . . is adapted to *tiltingly move*." Plaintiff, by its charge of infringement here, perforce contends that the applicator supports in defendant's tables so "tiltingly move." If this is true, then the applicator supports in the Parker and Gunderman patents likewise "tiltingly move" because they have the same simple harmonic motion as the supports of defendant's tables and are operated by substantially the same mechanism.

" . . . and means to oscillate said applicator axially of the length of said couch-like structure. . . ."

As pointed out by plaintiff-patentee Stauffer, this merely means that the applicator, pad, or seat is moved back and forth with respect to the top of the table [R. 342].

Obviously, the applicators 17 of the Parker patent oscillate back and forth lengthwise of the table in the same fashion; the applicator pad 27 of the Miller patent moves in the same way; the vibrating applicator plates 26 of the Gunderman patent move in the same way with respect to its base 11.

The limitation in claim 1 of Stauffer that the applicator moves "axially" of the length of the couch-like structure does not add any novelty. This means that it moves along the longitudinal center line of the couch. The same is true of the applicator 27 of the prior art Miller patent [R. 451].

Thus, all of the mechanical elements set forth in claim 1 of the Stauffer patent in suit were old in the prior art in which they operated in substantially the same way to produce substantially the same result, exactly as found by the District Court in Finding 7 [R. 49]. There is thus ample evidence in the record supporting Finding 7, and there being no evidence to the contrary, the finding is not in any respect erroneous as to its factual basis.

The law is well established that where, as here, all of the elements of the claim in suit are found in the prior art where they operate in substantially the same way to produce substantially the same result, the claim is invalid in law:

*See:*

*Kwikset Locks, Inc. v. Hillgren*, 210 F. 2d 483  
(C. A. 9th, 1954);

*Himes v. Chadwick*, 199 F. 2d 100 (C. A. 9th,  
1952).

Finding of Fact 7 [R. 49] goes on to find as a fact that the subject matter of claim 1 of the Stauffer patent in suit “as a whole would have been obvious to and could have been produced by any person having ordinary skill in the art to which said subject matter pertains.” Appellant’s Opening Brief makes no attempt whatever to show that this portion of Finding 7 is in any respect erroneous.

Finding of Fact 7, not seriously questioned by appellant, is determinative of this appeal when considered in connection with Section 103 of Title 35 of the United States Code as follows:

**“§103. Conditions for patentability; non-obvious subject matter.—**

A patent may not be obtained though the invention is not identically disclosed or described as set forth in section 102 of this title, if the differences between the subject matter sought to be patented and the prior art are such that the subject matter as a whole would have been obvious at the time the invention was made to a person having ordinary skill in the art to which said subject matter pertains. . . .”

Claim 1 of the Stauffer patent in suit covers merely an assemblage of elements old in the prior art, and the District Court in holding it invalid properly followed the rule enunciated and applied in *A. & P. Tea Co. v. Supermarket Corp.*, 340 U. S. 147; and by this Court in *Kwikset Locks v. Hillgren*, 210 F. 2d 483 (C. A. 9th, 1954), and *Oriental Foods, Inc. v. Chun King Sales, Inc.*, ..... F. 2d ....., 113 U. S. P. Q. 404 (C. A. 9th, May 16, 1957).

As stated by this Court in *Oriental Foods, Inc. v. Chun King Sales, Inc.*, *supra*:

“We believe that that patent involved in the instant cause rightfully belongs, to use the words of

Justice Douglas, among the 'list of incredible patents which the Patent Office has spawned.' 340 U. S. at 158. It is a trifling device at best. It makes no substantial contribution to the advancement of the arts . . . Placed aside the Constitutional criteria for invention, this device does not measure up."

#### D. Infringement Is Not an Issue Before the Court on This Appeal.

The District Court here entered no findings of fact or conclusions of law as to whether claim 1 of the Stauffer patent in suit is infringed by defendant's accused machines. Having held claim 1 invalid, it was unnecessary for the District Court to make any findings of fact or conclusions of law as to infringement.

See:

*Oriental Foods, Inc. v. Chun King Sales, Inc.*,  
..... F. 2d ....., 113 U. S. P. Q. 404 (C. A.  
9th, May 16, 1957).

If this Court affirms the decision of the District Court in holding claim 1 of the Stauffer patent in suit invalid in law, this Court not only need not, but, we suggest, should not consider the issue of infringement. See: *Oriental Foods, Inc. v. Chun King Sales, Inc.*, *supra*.

If this Court reverses the decision of the District Court as to the invalidity of claim 1 of the Stauffer patent in suit, the action should be remanded to the District Court with directions to it to enter suitable findings of fact and conclusions of law on the infringement issue. This procedure is indicated by the following authorities:

"The question of validity of the claims here involved cannot properly be determined on this appeal.



Such a determination would necessitate findings on questions on which the District Court has made no findings—the question of novelty and the question of invention, both of which are questions of fact. Such findings should be made by the District Court, not by this court.

“The judgment is vacated and the case is remanded to the District Court with directions to determine the question of validity of the claims here involved, determine the question of their infringement, make findings of fact and state conclusions of law, as required by Rule 52(a) of the Federal Rules of Civil Procedure, and thereupon enter such judgment as may be proper.”

*Helbush v. Finkle*, 170 F. 2d 41 at 42 (C. C. A. 9th 1948).

“The patent claims in suit being invalid, we will not decide or discuss the issues of infringement, upon which the district court made no findings. In *Hazeltine Corporation v. Crosley Corporation*, 6 Cir., 130 F. 2d 344, 349, *supra*, we asserted that, in patent cases as well as in mill-run civil actions, a reviewing court would violate both the letter and the spirit of Civil Procedure Rule 52, should it pass upon a controverted issue of fact not determined in the trial court. There, the district court, having held the patent claims in suit not to be infringed, had made no findings and had drawn no conclusions with respect to the validity of the patent. In the present case, having held the patent claims invalid, the district court made no findings with respect to infringement. The same reasoning applies. On this review, the issues of infringement should not be passed upon. In *Dow Chemical Company v. Halliburton Oil Well Cementing Company*, 324 U. S. 320, 65 S. Ct. 647,

*supra*, the Supreme Court expressly pretermitted decision upon infringement in like circumstances.”

*O’Leary v. Liggett Drug Co.*, 150 F. 2d 656 at 667 (C. C. A. 6th, July 1945).

*And see:*

*Stearns v. Tinker & Rasor*, 220 F. 2d 49 (C. A. 9th 1955).

As shown in the following sections of this brief, however, defendant’s accused machines clearly do not infringe claim 1 of the Stauffer patent in suit.

### **E. Defendant’s Machines Do Not Infringe Claim 1 of the Stauffer Patent in Suit.**

Appellant’s Opening Brief (pp. 13-14), in a curiously desultory fashion, argues infringement here.

To establish infringement of a patent, a plaintiff must establish that: (a) the accused device includes all of the elements of the claim in suit, in which (b) such elements operate in substantially the same way, (c) to produce substantially the same result.

*See:*

*Craftint Mfg. Co. v. Baker*, 94 F. 2d 369 (C. C. A. 9th 1938);

*Burgess Battery Co. v. Coast Insulating Corp.*, 114 F. 2d 779 (C. C. A. 9th, 1940);

*Air Device v. Air Factors*, 210 F. 2d 481 (C. C. A. 9th, 1954).

Merely reading the claim in suit on the accused structure, as Appellant’s Opening Brief (pp. 13-14) attempts to do, does not establish infringement.

See:

*Grant v. Koppl*, 99 F. 2d 106 (C. C. A. 9th, 1938);  
*Kemart Corp. v. Printing Arts Research Laboratories*, 201 F. 2d 624 (C. A. 9th, 1953).

We therefore suggest that appellant has wholly failed to carry its burden of proof to establish infringement, and that the decision of the District Court can properly be affirmed on this ground alone. However, the evidence in this action definitely and conclusively establishes non-infringement and this evidence and its effect is reviewed hereinafter.

**1. Defendant's Machines Do Not Include Certain of the Important Elements of Claim 1 and Thereby Do Not Infringe.**

Defendant's machines do not have "a single flat rectangular applicator" as defined by claim 1 of the Stauffer patent in suit. As shown in the drawings of defendant's machines, Exhibits 16 and 17, each machine has *two pairs* of applicators, side-by-side, as described by the expert Dr. Knapp [R. 210]. Claim 1 of the Stauffer patent was rejected by the Patent Office until the word "single" was inserted in the claim (*See*: Plate III appended hereto). Thus, it is a material limitation of claim 1 that it covers only a machine having a *single* applicator, and defendant's machines having *two pairs* of side-by-side applicators do not infringe.

It is elementary patent law, that where an applicant for a patent has specifically limited his claim to obtain its allowance and avoid the prior art, by the doctrine of "file-wrapper estoppel" the patentee cannot thereafter expand his claim to cover a device covered by the original

claim but not covered by the claim as so amended. The rule was concisely stated by Chief Justice Hughes in *Smith v. Magic City Kennel Club, Inc.*, 282 U. S. 784, at 789, 51 S. Ct. 291, 75 L. Ed. 707, as follows:

“The case, in our opinion, thus calls for the application of the principle that where an applicant for a patent to cover a new combination is compelled by the rejection of his application by the Patent Office to narrow his claim by the introduction of a new element, he cannot after the issue of the patent broaden his claim by dropping the element which he was compelled to include in order to secure his patent. *Shepard v. Carrigan*, 116 U. S. 593, 597 . . . The applicant having limited his claim by amendment and accepted a patent, brings himself within the rules that if the claim to a combination be restricted to specified elements, all must be regarded as material, and that limitations imposed by the inventor, especially such as were introduced into an application after it had been persistently rejected, must be strictly construed against the inventor and looked upon as disclaimers. *Sargent v. Hall Safe & Lock Co.*, 114 U. S. 63, 86; *Shepard v. Carrigan*, *supra*, 598; *Hubbell v. United States*, *supra*, 85. The patentee is thereafter estopped to claim the benefit of his rejected claim or such a construction of his amended claim as would be equivalent thereto. *Morgan Envelope Co. v. Albany Paper Co.*, 152 U. S. 425, 429.”

*And see:*

*I. T. S. Rubber Co. v. Essex Rubber Co.*, 272 U. S. 429, 47 S. Ct. 136, 71 L. Ed. 335;

*Schriber-Schroth Co. v. Cleveland Trust Co.*, 311 U. S. 211, 61 S. Ct. 235, 85 L. Ed. 132.

Secondly, defendant's machines do not employ any *flat* applicators, defendant's applicators being rounded on top [See: the illustrative drawing of defendant's applicators, Ex. C], quite similar to the rounded applicator 26 of the Gunderman prior art patent [R. 462]. An applicator pad quite similar to those in defendant's machines is also shown in the prior art Miller patent [R. 451, see Fig. 4]. The Stauffer patent in suit shows a *flat* applicator or seat 18 [R. 392], and the plaintiff-patentee Stauffer testified in effect that it is essential in his patent in suit to use a *flat* applicator and not a curved applicator as shown in the Gunderman patent [R. 345-346]. Defendant's machines, omitting this essential element of claim 1 of the Stauffer patent, thereby avoid infringement, it being well established that the omission from a defendant's device of an essential element claimed in the patent in suit avoids infringement.

*See:*

*Burgess Battery Co. v. Coast Insulating Corp., supra.*

Furthermore, in defendant's machines the side-by-side pairs of applicators do not oscillate "axially" of the length of the couch as specified by claim 1 of the Stauffer patent in suit. In the Stauffer device the applicator 18 moves lengthwise of the couch along the center line or *axially*, whereas defendant's applicators move on paths on each side of the center line (as do the side-by-side applicators of the prior art patents to Parker [R. 446] and Gunderman [Figs. 2 and 4, R. 462, 463]).

Thus, defendant's machines omit several of the material structural limitations of claim 1 of the Stauffer patent and thereby avoid infringement.



2. Defendant's Machines Do Not Have the Same Mode of Operation as That of the Stauffer Patent.

The evidence establishes clearly that defendant's machines do not operate in the same way, *i. e.*, have the same "mode of operation," as the table of the Stauffer patent in suit, and thereby avoid infringement.

Mr. Stauffer's testimony made it very plain that to obtain the required "lifting effect" on a human body essential in his patent in suit it is essential to employ a *flat* applicator and that if rounded applicators, such as shown in the prior art patent to Gunderman, are used this "lifting effect" cannot be attained [R. 345-346]. As pointed out in the preceding section (Sec. E(1)) of this brief, defendant's machines use such rounded applicators. Dr. Fishbein definitely testified that in the operation of defendant's accused machines there is no "lifting effect" whatever on the human body [R. 301; 304-305] and this is uncontroverted. There is no evidence in this record that defendant's tables produce such a "lifting effect" and all of the evidence is to the contrary.

Furthermore, as pointed out above, in the machine of the Stauffer patent the support 20 for the flat applicator or seat 18 moves through an arc of about  $10^{\circ}$  on only one side of the vertical. Mr. Stauffer admitted that this type of movement is a *very important* factor in the operation of the machine of the patent in suit, and is one of its *essential* factors [R. 147]. The evidence is uncontroverted, however, that defendant's machines do not have this type of movement because in defendant's machines the supports for the applicators move through an arc from one side of the vertical to the other side of the vertical and back.

Sheet 1 of the original drawings in the application for the Stauffer patent [R. 412] showed a device in which the applicator support 20 moved in an arc from one side of the vertical to the other side of the vertical and back. The applicant Stauffer, however, amended his drawing to show the applicator support moving through an arc on only one side of the vertical, and amended his specification to so limit such movement of the applicator support 20 [R. 415-416]. Thus, although the original Stauffer application showed and claimed the type of movement of the applicator supports of the defendant's accused machines, Stauffer amended his application to show and define a movement on only one side of the vertical.

It is well established in the law that where an applicant cancels from the original application one form of his alleged invention, this constitutes a dedication to the public of such form cancelled, and the patentee cannot thereafter attempt to expand the claims of his patent to cover the specific form cancelled from his application.

*See:*

*Ruud Mfg. Co. v. Long-Landreth-Schneider Co.*,  
250 Fed. 860 (C. C. A. 2d, 1918);

*Lincoln v. Waterbury Button Co.*, 291 Fed. 594  
(D. C. Conn., 1923);

*Aeration Processes, Inc. v. Lange*, 196 F. 2d 981  
(C. A. 8th 1952).

Since, in defendant's machines the applicator supports do not move in an arc on only one side of the vertical, and since the Stauffer patent discloses and is limited to such a construction, defendant's tables do not have the same "mode of operation" as the device of the patent in suit and, therefore, do not infringe.

It is also to be noted that in the device of the Stauffer patent the applicator 18 moves faster in one direction than in the other [R. 204-205], presumably to provide the "differential up-stroking or lifting" described therein, while in defendant's machines the applicators move in *simple harmonic motion* equally fast in both directions [R. 228-229], an entirely different type of motion. This conception of moving the applicator faster in one direction than in the other was a function of the device originally claimed by Stauffer in original claims 5, 6, and 7 of his patent application [R. 409-410]. Thus, again, defendant's tables have a "mode of operation" different from that of the device of the Stauffer patent in suit.

The defendant's physical Exhibit K provides a ready comparison of the relative movement of the support 20 of the Stauffer patent in suit and the supports of the defendant's accused machines [R. 287-288.] It clearly shows that the arc of movement of the Stauffer applicator is entirely on one side of the vertical but that in defendant's machines the movement is on both sides of the vertical. Moreover, this exhibit clearly demonstrates that plaintiff's and defendant's arcs of movement *at no time* overlap, but are in fact wholly different.

It is further to be noted that claim 1 of the Stauffer patent requires that its applicator support "is adapted to *tiltingly* move." The word "tiltingly" was added to the claim to avoid a rejection by the Patent Office of the claim on the prior art. At the same time the specification of the Stauffer patent application was amended to state: "This arrangement causes the seat 18 to lie *at a constant* although variable angle *with respect to the upper surface of the couch* [R. 415]." Thus, the word "tiltingly" means simply that the upper surface of the seat or applicator 18

is always at an angle or tilted with respect to the top of the couch (as shown in the drawing of the Stauffer patent) [R. 264-266]. Defendant's applicators in their central positions of movement are substantially horizontal with respect to the top of the couch or table.

Thus, we submit, defendant's machines have a mode of operation entirely different from that of the machine of the Stauffer patent in suit and thereby avoid infringement.

### **3. Defendant's Machines Do Not Produce the Alleged Results of the Machine of the Stauffer Patent.**

The Stauffer patent in suit [R. 394] makes a long list of claims of therapeutic results and effects derived from the operation of its table (page 1, Column 1, line 15, to Column 2, line 4; page 2, Column 2, lines 11-64). Dr. Fishbein, defendant's accredited medical expert having wide experience with defendant's machines and having made extensive medical studies of their effects on women [R. 295-297], established in uncontroverted fashion that defendant's accused machines produce substantially *none* of these results claimed in the Stauffer patent [R. 297-305].

Although Mr. Stauffer contended that the machine of the Stauffer patent effects a stretching of the muscles of the body [R. 94-95], plaintiff made no attempt to establish that defendant's machines accomplish this, and Dr. Fishbein testified positively that defendant's machines do not stretch any muscles [R. 311]. This is merely illustrative.

There was no attempt made by plaintiff in the evidence to establish any similarity of results attained by defendant's accused machines and that of the Stauffer patent

in suit, and all of the defendant's evidence is to the contrary. Thus, we suggest, the record is clear that defendant's machines do not produce the same results claimed by plaintiff for the machine of the Stauffer patent in suit. This, in itself, establishes lack of infringement.

It is to be noted that the only issue here is a comparison between the construction and operation of the machine of the Stauffer patent in suit and defendant's accused machines. There is no comparison to be made between plaintiff's commercial machines and defendant's machines, because there is no evidence to show that plaintiff's present commercial machines (*e. g.*, PX-2) embody any alleged invention of the patent in suit. It is our position that plaintiffs' commercial machines do not embody the alleged invention of the Stauffer patent because: (a) they do not use a *flat* applicator, as shown and claimed therein; (b) the applicator moves on both sides of the vertical exactly as do the applicators of the prior art patents to Parker and Gunderman; and (c) the top of the applicator is not at all times tilted with respect to the horizontal as described and claimed in the Stauffer patent. True, Mr. Stauffer improperly testified (over our objection) that his commercial tables embody the invention of his patent [R. 102-103], but this is a mere legal conclusion and is not evidence.

We, therefore, submit that plaintiff has failed to establish infringement, because he has wholly failed to show that defendant's accused machines have the same elements which operate in substantially the same way to produce substantially the same results as the device of his patent in suit. We further submit that the evidence in this action clearly establishes the negative of each of these requirements for a determination of patent infringement.



V.

CONCLUSION.

The District Court held that claim 1 of the Stauffer patent in suit defines an assemblage of elements all of which were old in the prior art in which they operated in substantially the same way to produce substantially the same result, and that such subject matter would be obvious to any mechanic having ordinary skill in the art, and that by reason thereof claim 1 is invalid for lack of invention. Such findings and decision are amply supported by the evidence, and appellant has shown no error of any kind therein.

We respectfully submit that the decision of the District Court should be affirmed with costs to appellee.

Respectfully submitted,

HARRIS, KIECH, FOSTER & HARRIS,

FORD HARRIS, JR.,

NEWLIN, TACKABURY & JOHNSON,

HUDSON B. COX,

*Attorneys for Appellee.*



128  
52

679  
5-6-41

Print of drawing as originally filed.

Fig. 1

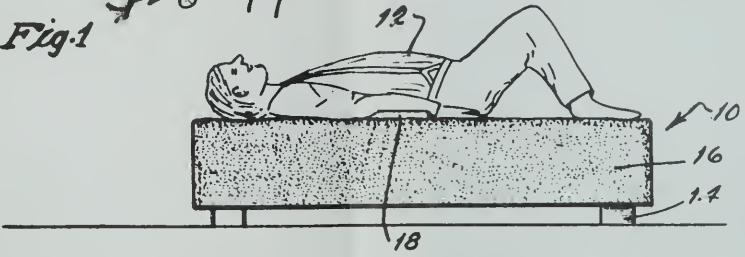
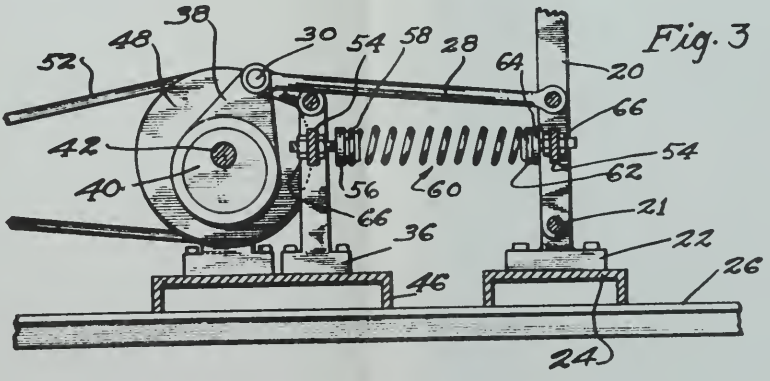
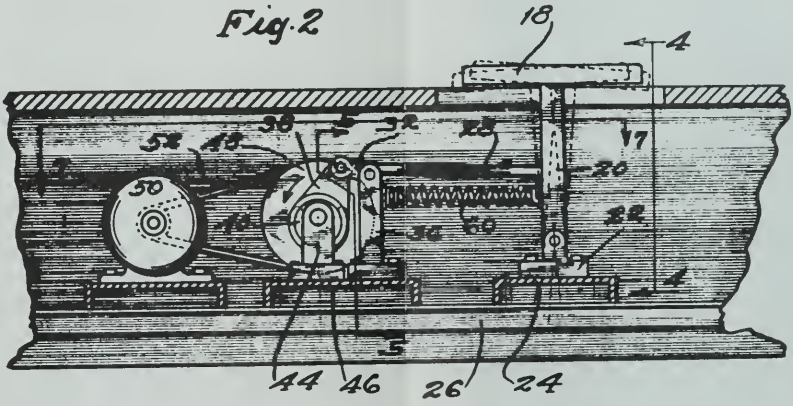

Fig. 2



my d... plate rough... cannot...  
It can be...

INVENTOR.  
Bernard H. Stauffer  
BY *Phil Woolley*  
ATTORNEY.

55

13 128-70

222327



May 6, 1941.

B. H. STAUFFER

2,240,679

MUSCLE RELAXING MACHINE

Filed Aug. 1, 1938

2 Sheets-Sheet 1

Fig. 1.

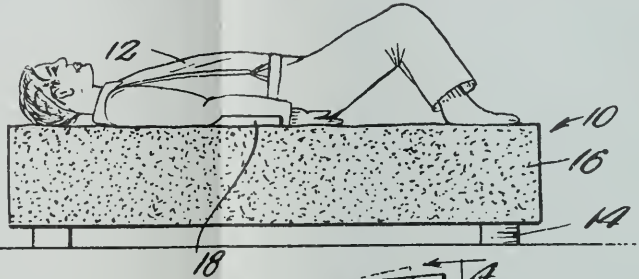

Fig. 2.

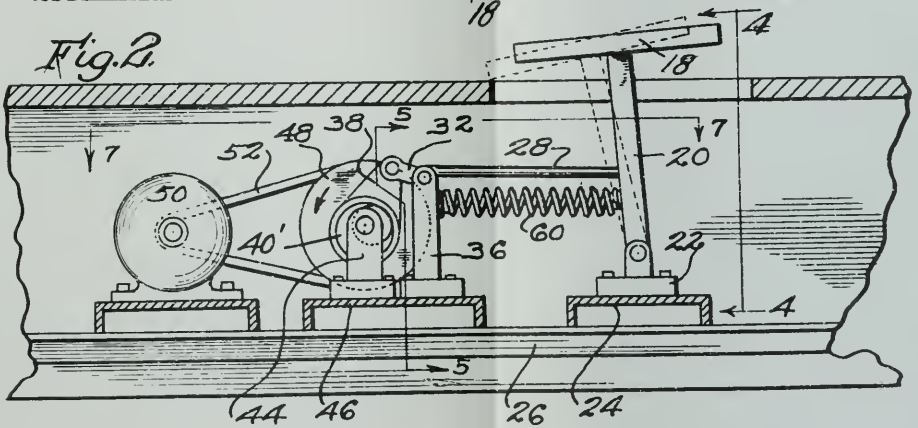
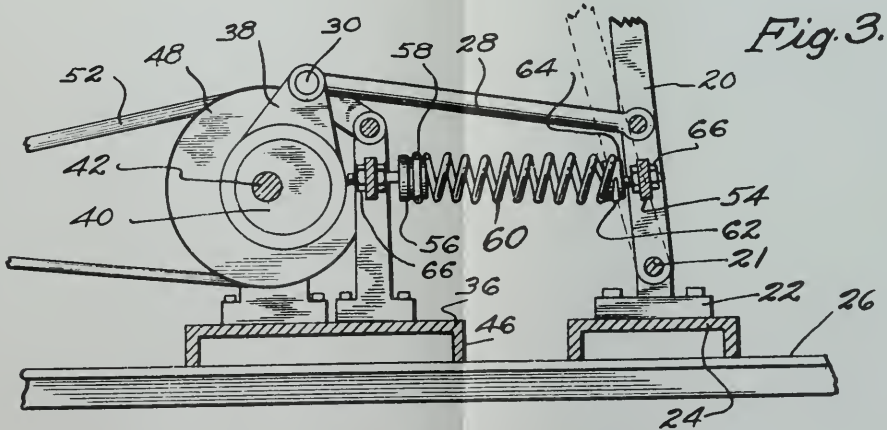

Fig. 3.



INVENTOR.  
*Bernard H. Stauffer*  
 BY





Los Angeles, California.  
January 17, 1940.

JAN 25 1940

C 615  
B

MAIL DIVISION

JAN 24 1940

OFFICE

DIV. 55  
Bernard H. Stauffer

S. N. 222,327  
Filed, Aug. 22, 1939  
For, Muscle Relaxing  
Machines.

Division No. 55  
Room No. 6833  
Paper No. 5

Commissioner of Patents

Washington, D.C.

Sir:

In response to office action dated November 8, 1939, the above entitled application is amended as follows, and it is requested that this amendment be inserted in the original document.

Cancel claims 1, 3, 5, and 7.

Add the following new claim:

~~(10)~~ A muscle relaxing machine comprising a couch-like structure for repose of a human body in the top surface of which a slot-way is formed and through which a vertically directed and oscillatable support for a <sup>single</sup> flat rectangular applicator is adapted to <sup>oscillate</sup> move, and means to oscillate said applicator axially of the length of said couch-like structure whereby zonular areas of the body may be massaged by mechanical manipulation in a substantially horizontal plane.

Claims 1, 3, 5, and 7 have been canceled in view of the record. Claims 8 and 9 are retained, being again submitted for action on their merits and as supported by the following argument.

Per C  
"C"  
B  
H  
H

CH 1



No. 15,418

IN THE

# United States Court of Appeals

FOR THE NINTH CIRCUIT

---

BERNARD H. STAUFFER,

*Appellant,*

*vs.*

SLENDERELLA SYSTEMS OF CALIFORNIA, INC.,

*Appellee.*

---

## APPELLANT'S REPLY BRIEF.

---

LYON & LYON,

CHARLES G. LYON,

811 West Seventh Street,  
Los Angeles 17, California,

*Attorneys for Plaintiff-Appellant.*

FILED

JUL - 8 1957

PAUL P. O'BRYEN, CLERK

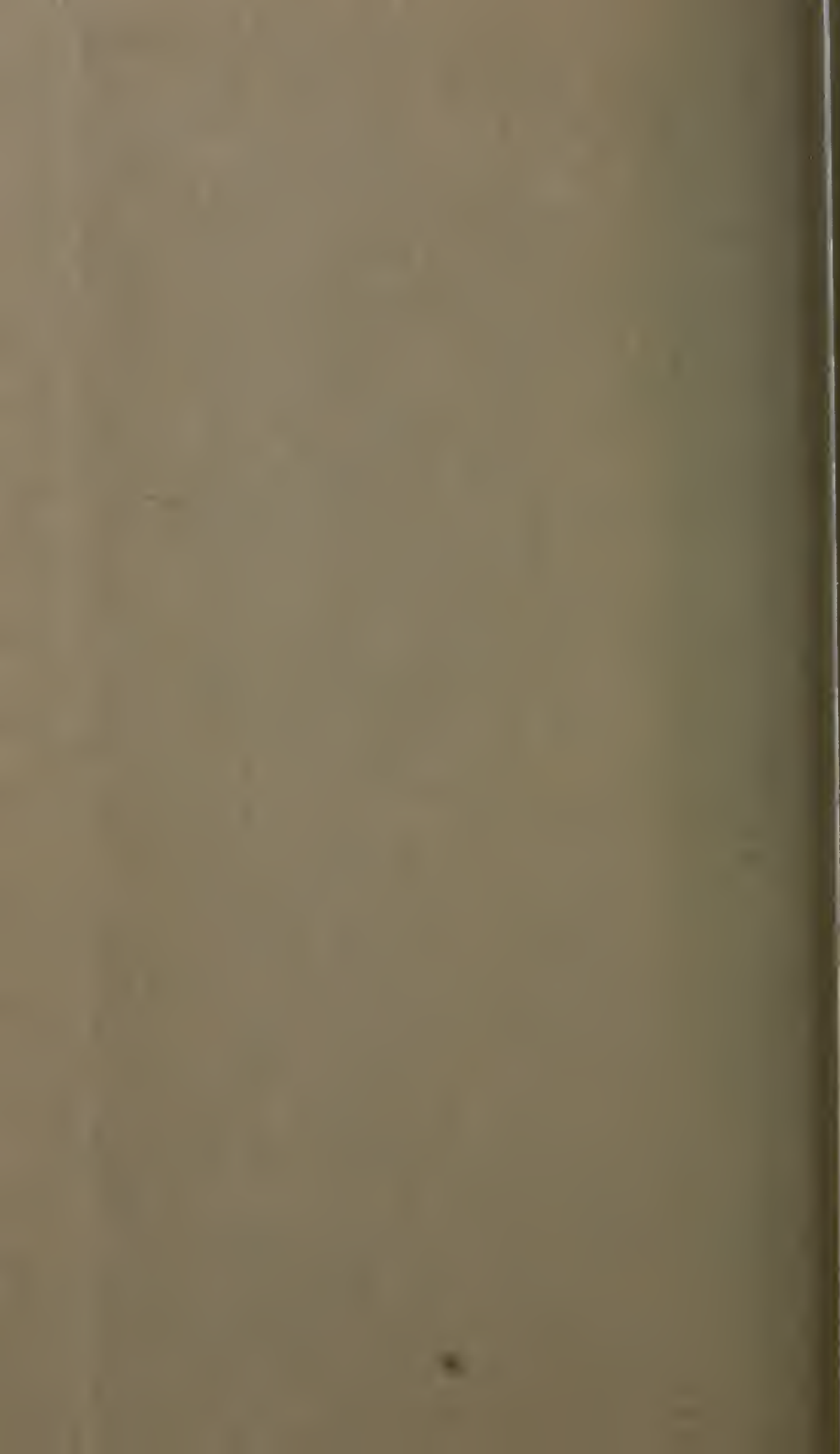



## TOPICAL INDEX

	PAGE
Stauffer Patent No. 2,240,679 Is Valid.....	1
Finding of Fact 7 Is Clearly Erroneous.....	2
The Prior Art Does Not Achieve the Result of the Patented Combination nor Does It Function in the Same Way.....	4
Parker Patent No. 1,978,223 Does Not Achieve the Result or Function in the Manner of the Patent in Suit.....	4
Miller Patent No. 1,953,424 Does Not Achieve the Result or Function in the Manner of the Patent in Suit.....	5
Gunderman Patent No. 1,825,588 Does Not Achieve the Result or Function in the Manner of the Patent in Suit.....	5
Claim 1 of the Patent in Suit Is Infringed.....	6
Conclusion .....	12

TABLE OF AUTHORITIES CITED

CASES	PAGE
Aluminum Co. of America v. Thompson Products, Inc., 122 F.2d 796 (6 Cir.).....	11
Baker-Cammack Hosiery Mills, Inc. v. Davis Co., 181 F.2d 550 (4 Cir.) .....	11
Consolidated Contract Co. v. Hassam Paving Co., 227 Fed. 439	2
Derman v. Stor-Aid, Inc., 141 F.2d 580 (2 Cir.).....	11
Graver Tank & Mfg. Co. v. Linde Air Products Co., 336 U. S. 271 .....	11
Kennedy v. Trimble Nurseryland Furniture, Inc., 99 F.2d 786 (2 Cir.).....	11
Los Angeles Art Organ Co. v. Aeolian Co., 143 Fed. 880, 885 (9 Cir.) .....	11
Oxnard Cannery v. Bradley, 194 F.2d 655.....	2
Page et al. v. Myers, 155 F.2d 57.....	2
Pointer v. Six Wheel Corp., 177 F.2d 155.....	2
Reinharts, Inc. v. Caterpillar Tractor Co., 85 F.2d 628, 633 (9 Cir.) .....	11
Samson-United Corp. v. Sears, Roebuck & Co., 103 F.2d 312 (2 Cir.) .....	8
Sutherland Paper Co. v. Auburn Carton Corp., 118 F.2d 862 (7 Cir.) .....	7
Webster Loom Co. v. Higgins, 105 U. S. 580, 591, 26 L.ed 1177	2
Western States Mach. Co. v. S. S. Hepworth Co., 147 F.2d 345 (2 Cir.) .....	11
Wire Tie Mach. Co. v. Pacific Box Corp., 102 F.2d 543, 107 F.2d 54 .....	2

TEXTBOOK

Walker on Patents, Deller's Edition, Sec. 462.....	7
--	---

No. 15,418

IN THE

# United States Court of Appeals

FOR THE NINTH CIRCUIT

---

BERNARD H. STAUFFER,

*Appellant,*

*vs.*

SLENDERELLA SYSTEMS OF CALIFORNIA, INC.,

*Appellee.*

---

## APPELLANT'S REPLY BRIEF.

---

### **Stauffer Patent No. 2,240,679 Is Valid.**

In our opening brief we pointed out that it was error for the District Court to decide, as it did, "that it is so simple that the structure which has been developed here by Mr. Stauffer is a structure which could reasonably be expected to have been developed by one having ordinary skill in that art and that it just does not rise to the level of invention, as invention is protected by the patent laws." [R. 380-1.]

We were somewhat surprised, in view of the District Court's statement concerning the prior art,

"The court cannot see a great deal of similarity between Miller, Gunderman, Parker and Stauffer. They have some things in common, but it cannot be said that these that I have just enumerated anticipate Stauffer in the way that prior art is supposed to anticipate with respect to patent law." [R. 380.],

to see a finding of fact based upon such prior art. But nevertheless Finding 7 is in the record and is the principal reliance of appellee herein. We shall, therefore, demonstrate that it is erroneous.

### Finding of Fact 7 Is Clearly Erroneous.

Finding of Fact 7 reads as follows:

“7. Claim 1 of said Letters Patent No. 2,240,679 in suit defines an assemblage of elements all of which were old in the prior art in which they operated in substantially the same way to produce substantially the same result, and such subject matter as a whole would have been obvious to and could have been produced by any person having ordinary skill in the art to which said subject matter pertains.”

This finding cannot stand if it can be demonstrated that contrary to the finding that the elements in the prior art “operated in the same way to produce substantially the same result” the elements of the patented invention combine to perform an entirely new result in an entirely new way.

The rule announced by the Supreme Court in *Webster Loom Co. v. Higgins*, 105 U. S. 580, 591, 26 L. Ed. 1177, that “where a new combination of old elements produces a new and beneficial result never attained before, it is invention” has been consistently followed by this court:

*Oxnard Cannery v. Bradley*, 194 F. 2d 655;

*Pointer v. Six Wheel Corp.*, 177 F. 2d 155;

*Page, et al. v. Myers*, 155 F. 2d 57;

*Wire Tie Mach. Co. v. Pacific Box Corp.*, 102 F. 2d 543, 107 F. 2d 54;

*Consolidated Contract Co. v. Hassam Paving Co.*, 227 Fed. 439.

Now in our opening brief, we pointed out that the patented combination operates in a certain way to produce a certain result.

This function and result were explained by the inventor as follows:

“Q. With the portion of the body supported on the couch, and a portion of the body, shall we say, the buttocks, being supported on the pad 18, when you reciprocate that arm 20, carrying the pad through the arc indicated in your patent, what happens.” [R. 94.]

\* \* \* \* \*

“The Witness: The applicator that is carrying the weight induces a traction effect on the part of the body that is stationary. The weight of the body carried by the applicator causes a stretching effect between those areas of the body that are stationary, carried by the couch.

“And it is between this action and this weight of the body, carried on the couch, that you get the stretching effect or the traction in the various muscle areas.” [R. 94, 95.]”

And again on rebuttal:

“Q. Is a couch an important part of your device, your patent?”

“A. It is very important because it allows that part of the body that is not on the movable platform to act as an anchor, in which the motion of the platform stretches the muscular tissue between the anchored part and the movable part, thus giving traction (indicating).” [R. 343.]

In our opening brief, we asserted “No prior apparatus which functions in this way or achieves this result has



been produced.” This statement remains unchallenged, and perhaps we could rest upon that. We will, however, demonstrate that the art relied upon by appellee does not achieve this result nor function in this way.

**The Prior Art Does Not Achieve the Result of the Patented Combination nor Does It Function in the Same Way.**

The prior art in this case consists of the prior patents to Parker [R. 446], Miller [R. 451] and Gunderman [R. 462] referred to in the quotation from the District Court’s oral opinion, *supra*. The other patents in the book of exhibits and referred to on pages 19 and 20 of appellee’s brief are in evidence solely to show what was before the Patent Office during the prosecution of the patent in suit. [R. 293.] They are not pleaded as prior art and appellee’s reference to them in the manner done in its brief is improper. These other patents will therefore be disregarded here.

**Parker Patent No. 1,978,223 Does Not Achieve the Result or Function in the Manner of the Patent in Suit.**

The essence of the Stauffer System and of the patent in suit is the manipulation of one part of the body, supported upon the applicator 18 of the Stauffer Patent against the weight of the remainder of the body supported on the couch 10. The hoods 17 of Parker are obviously not designed for or capable of supporting or manipulating any portion of the body of the patient. They are designed to give a vibratory massage as close to the spinal process as possible without irritating them. [See R. 466, p. 2, column 2, lines 82-93 of the Parker Patent.]

The word “single” in Claim 1 of the patent in suit was added to the claims to distinguish from Parker’s

series of six separate pairs of applicators, each designed to massage a different area along the spine.

Parker could not be used to give a Stauffer (or Slen-derella) treatment. [R. 346.]

**Miller Patent No. 1,953,424 Does Not Achieve the Result or Function in the Manner of the Patent in Suit.**

Miller has a couch for a patient, straps for pulling down on his body and a pad for pushing upwardly. It is a "lymph pump."

The patent states: "\* \* \* The chest and back pads 28 and 27 respectively operate in unison, that is, as the chest straps are pulled downwardly to contract the chest, the back pad 27 simultaneously presses upwardly against the spine."

Concerning this, appellee's expert witness, Dr. Knapp, testified: "I would say the patentee thinks he is getting an upwardly pressing movement." [R. 287.]

Certainly this is not the manipulation of the body described by Mr. Stauffer; it is more like artificial respiration, and the District Court was justified in not finding much similarity to Stauffer.

**Gunderman Patent No. 1,825,588 Does Not Achieve the Result or Function in the Manner of the Patent in Suit.**

Gunderman [R. 462] is a portable vibrating machine. It has no couch, and no gear reduction. [R. 237.] Electric motors as of January 29, 1929 ran 1700-1800 rpm. [R. 282, cross-examination of Dr. Knapp.] Certainly no one would suggest manipulating one portion of the body of a patient against the anchor of the remaining portion of

the body at 1700 rpm, and if you did you would merely shake the body, *i. e.*, vibrate it, and you would not achieve passive exercise.

Thus we are forced to the conclusion that though the individual elements of the Stauffer invention, *i. e.*, couches, slots in the couches, pads, pitmans, motors, etc., may be old in the art, they are assembled to form a new combination which achieves a new result by functioning in a new way.

From the authorities cited above, such a combination involves invention and Finding 7 and Conclusion 2 based thereon are obviously clearly erroneous and should be reversed.

### Claim 1 of the Patent in Suit Is Infringed.

In our opening brief, we demonstrated on pages 13 and 14 how Claim 1 of the patent in suit is read upon and applied to the accused devices. We now find the defendant arguing on specious reasoning that the accused devices, though literally copied by defendant's president, Lawrence Mack, who was a previous manager of plaintiff's operations in Chicago, for one technical reason or another do not infringe. The first of these arguments is based upon the fact that Claim 1 calls for "a single applicator \* \* \* to oscillate \* \* \* axially of the length of said couch like structure."

We fully agree with the defendant that the word "single" in this claim was inserted in order to distinguish from the Parker Patent [R. 446] which shows six pairs of applicators disposed longitudinally of the couch so as to apply massage adjacent the spine longitudinally of the body, and we fully agree that had the defendant used such a device wherein a multiplicity of applicators were thus

arranged in a line, the claim would not be infringed. However, any claim in any patent is entitled to some range of equivalents, and it is fundamental patent law that one may not escape a claim by simply taking an element of the claim, dividing it in half and then locking the two halves together to act as a unit. This is what the defendant has done when it takes the applicator of the patent in suit and divides it in half so as to provide two applicators side by side but both mounted on the same shaft and locked together by a clutch so that they operate in unison. Assuming for instance that the device is used in the buttocks supporting position, this merely means that one ham will be upon one of the applicators and the other upon the other applicator rather than both lying on the single applicator of the patent in suit. The resulting stretching of the muscles, *i. e.*, the resulting passive exercise, is imparted in exactly the same manner. As a result we have a device operating through substantially the same instrumentalities to produce the identical result which is the full meaning of the doctrine of mechanical equivalence.

That such a dividing or duplication or multiplication of parts is ineffective to escape infringement is well decided. *Walker on Patents, Deller's Edition*, Section 462, collects a list of a long series of cases on this point.

Directly in point is the case of *Sutherland Paper Co. v. Auburn Carton Corp.*, 118 F. 2d 862, 864 (7 Cir.). In this case, the claim called for a carton comprising a blank cut and scored in a certain manner to form an egg crate. The defendant took two pieces of paper and glued them together just as defendant in this case takes two applicators and locks them together with a clutch. Concerning this, the Court of Appeals stated:

“Did defendants avoid infringement by using two pieces of paper and gluing them together and thereby

making one piece? For the purpose of determining infringement, defendants' two pieces, glued together, were one piece. Infringement was not avoided by using two pieces and gluing them together."

Also in point is the case of *Samson-United Corp. v. Sears, Roebuck & Co.*, 103 F. 2d 312 (2 Cir.) at 315, wherein the Court held:

"It is no departure from the patent to use a blank of blades instead of single blades or a two-piece hub instead of a one-piece hub to accomplish the same result."

In its clutching at straws, defendant next attempts to build a case for non-infringement out of the fact that the claim calls for the applicator to move axially of the couch. There is no question that the applicators of defendant's tables move longitudinally of the couch rather than transversely, but because of the fact that defendant has split the applicator in half, each half of course from necessity lies equally spaced from the center line of the couch and therefore moves parallel to said center line. That this is the full equivalent of a single applicator having its supporting rod in a plane which bisects the couch longitudinally and is the full equivalent of moving the applicator axially of the couch appears from the testimony of defendant's witness Knapp who testified as follows on cross-examination:

"Q. If I laid a board across those four pads and we were in this first cycle so the supports 11 and 11-A are in unison, would you then say that that board which I have laid across the top is being caused to move axially of the couch?"

"A. I would say the board could be considered to move axially along the couch." [R. 268.]



Defendant's argument next proceeds to seize at the word "flat" in Claim 1 and argues that it avoids infringing this element of the claim because the edges of its applicator are rounded as in the conventional edge of a chair seat. That the functioning parts of defendant's applicators are flat seems to require no further demonstration.

In its final argument with respect to non-infringement, defendant argues that it does not infringe because it does not employ a specific arc of movement detailed in the specification of the patent in suit and specifically claimed in Claim 2 thereof.

It will be noted that Claim 2 is not in issue, the plaintiff having elected to stand on Claim 1, and the record indicates that when both counsel for the appellee and counsel for the appellant attempted to inquire into the niceties of degree of arc employed, the District Court foreclosed this line of inquiry. Thus during the cross-examination of plaintiff's expert, the following took place:

"Q. And the same thing is true as to the location of the pivot point for the little crank that you have put on here in lucite? A difference in the location of that pivot point, even in a small amount, changes materially the arc arrangement in which the red applicator arm moves, does it not?"

"A. To a lesser degree, yes.

"The Court: I don't see these fine points of whether it does or does not are involved here in determining whether Claim 1 of the patent is or is not infringed.

"You might enlighten me, if I am just dense in not getting your point, but I can't see what you are driving at because it doesn't seem that Claim 1 relates at all to this subject, as to the fine points of it."

[R. 181.]

And in the cross-examination of defendant's expert, the following took place:

"Q. No, this is 17, that is correct. This drawing with the support being straight up in the air—I am talking about Section CC,—

"A. Yes.

"Q. —the maximum eccentricity is straight down, right?

"A. No, I don't know; this kind of a drawing I cannot tell on.

"The Court: *Would that make any difference under Claim 1 of this patent?*

"Mr. Lyon: I don't think so, sir, but what I am doing now is I am defending my exhibits. I am not worrying about the patent.

"The Court: But I am. That is what I have to decide, the patent and the accused structure, and it seems to the court that the claim of the patent does not call for all of this elaboration of matters which might be one way or the other and still be within that claim.

"Mr. Lyon: I agree with you. I won't belabor that any more." (Emphasis our own.) [R. 274, 275.]

The foregoing shows that the degree of arc through which the applicator is oscillated was not considered by the District Court to be at all pertinent to the question of infringement of Claim 1 of the patent. In this, the District Court was absolutely correct. It is significant that no mention of such degree of arc is made in Claim 1 but that Claim 2 (not in suit) specifically limits the arc to from 80° to 90°. It is well settled that in construing and applying the claims of a patent, a limitation which appears in a claim not before the court will not be read into a claim

in which it does not appear. This is established by a uniform series of cases:

*Reinharts, Inc. v. Caterpillar Tractor Co.*, 85 F. 2d 628, 633 (9 Cir.);

*Los Angeles Art Organ Co. v. Aeolian Co.*, 143 Fed. 880, 885 (9 Cir.);

*Baker-Cammack Hosiery Mills, Inc. v. Davis Co.*, 181 F. 2d 550 (4 Cir.);

*Western States Mach. Co. v. S. S. Hepworth Co.*, 147 F. 2d 345 (2 Cir.);

*Kennedy v. Trimble Nurseryland Furniture, Inc.*, 99 F. 2d 786 (2 Cir.);

*Derman v. Stor-Aid, Inc.*, 141 F. 2d 580 (2 Cir.);

*Aluminum Co. of America v. Thompson Products, Inc.*, 122 F. 2d 796 (6 Cir.).

As stated by the Supreme Court of the United States in *Graver Tank & Mfg. Co. v. Linde Air Products Co.*, 336 U. S. 271 at 277: "It would accomplish little to require that claims be separately written if they are not to be separately read." It follows, therefore, in construing Claim 1 of the patent in suit the District Court was correct in refusing to consider the degree of arc of Claim 2 as being part of Claim 1, and, therefore, the appellee's argument on pages 30-32 of its brief concerning this motion must fail.

In summary, therefore, it is respectfully submitted that on the issue of infringement appellant has demonstrated that each and every element of Claim 1 of the patent in suit is present either in its exact form or by a full mechanical equivalent in the accused devices, functioning in the same manner to produce the same result. This is infringement.

### Conclusion.

In conclusion it is respectfully submitted that the Stauffer Patent in suit operates in an entirely new way and produces an entirely new result and, therefore, embodies a meritorious and patentable invention and that Finding of Fact No. 7 of the District Court is clearly erroneous.

It is further submitted that Claim 1 of the patent in suit is obviously infringed and that this Court should enter a judgment reversing the District Court and directing the entry of judgment that Claim 1 of Stauffer Patent No. 2,240,679 is valid and has been infringed by the defendant.

LYON & LYON,

CHARLES G. LYON,

*Attorneys for Plaintiff-Appellant.*

No. 15419

---

United States  
Court of Appeals  
for the Ninth Circuit

---

UNITED STATES OF AMERICA,  
Appellant,

vs.

A. G. RUSHLIGHT & CO., a corporation,  
Appellee.

---

Transcript of Record

---

Appeal from the United States District Court for the  
District of Oregon

FILED

APR 10 1957

PAUL P. O'BRIEN, CLERK





No. 15419

---

---

United States  
Court of Appeals  
for the Ninth Circuit

---

UNITED STATES OF AMERICA,  
Appellant,  
vs.

A. G. RUSHLIGHT & CO., a corporation,  
Appellee.

---

Transcript of Record

---

Appeal from the United States District Court for the  
District of Oregon

---

---

Notice of Appeal Dated:	
Oct. 29, 1956.....	43
Jan. 18, 1957.....	73
Names and Addresses of Attorneys.....	1
Opinion .....	37
Order Extending Time to File Record and Docket Appeal .....	44
Pre-Trial Order .....	13
Statement of Points and Designation of Record (Appellant's—USCA) .....	114
Transcript of Proceedings and Testimony (Portions) .....	75
Witness:	
Williams, A. N.	
—direct .....	75
—cross .....	93
—redirect .....	109
—recross .....	112







## NAMES AND ADDRESSES OF ATTORNEYS

CHARLES K. RICE,  
Assistant Attorney General,

LEE A. JACKSON,  
Attorney,  
Department of Justice,  
Washington, D. C.,

C. E. LUCKEY,  
United States Attorney,

EDWARD J. GEORGEFF,  
Assistant United States Attorney,  
United States Courthouse,  
Portland, Oregon,  
  
For Appellant.

HUTCHINSON, SCHWAB & BURDICK,  
DENTON G. BURDICK, Jr.,  
420 Equitable Building,  
Portland 4, Oregon,  
  
For Appellee.

## III.

James W. Maloney was, from July 17, 1933, to September 1, 1947, the Collector of Internal Revenue for the District of Oregon, and Hugh H. Earle was, from September 1, 1947, to November 1, 1952, the Collector of Internal Revenue for the District of Oregon. At all times subsequent to October 30, 1952, R. C. Granquist has been the District Director of Internal Revenue for the District of Oregon.

## IV.

On or about March 15, 1944, plaintiff filed with the Collector of Internal Revenue for the District of Oregon its corporation excess profits tax return for the calendar year ending December 31, 1943, and on or about June 1944 the Commissioner of Internal Revenue made an assessment against the plaintiff for excess profits taxes for said year in the amount of \$96,802.87, which amount was paid to James W. Maloney and Hugh H. Earle, as Collectors of Internal Revenue, and R. C. Granquist as District Director of Internal Revenue, on the dates and in the amounts as follows:

Collector or Director to whom Paid	Date of Payment	Amount of Payment
James W. Maloney.....	March 15, 1944	\$ 3,988.60
James W. Maloney.....	July 5, 1944	4,412.83
James W. Maloney.....	October 30, 1944	16,046.93
James W. Maloney.....	November 25, 1944	10,000.00
James W. Maloney.....	March 13, 1945	25,084.08
Hugh H. Earle.....	March 31, 1952	32,401.25
Hugh H. Earle.....	April 16, 1952	4,275.99
R. C. Granquist.....	November 19, 1952	593.19
		<hr/>
	Total.....	\$ 96,802.87

## V.

That prior to the expiration of the time prescribed in Section 275 of the Internal Revenue Code for the assessment of excess profits taxes, the Commissioner of Internal Revenue and the plaintiff, pursuant to Section 276(b) of the Internal Revenue Code, agreed in writing that excess profits taxes of plaintiff for the year ending December 31, 1943, might be assessed at any time prior to June 30, 1949, and pursuant to Section 322(b)(3) of the Internal Revenue Code the time within which plaintiff could claim the refund of any overpayment in its excess profits tax for said year 1943 was extended to and including December 31, 1949.

## VI.

On or about August 23, 1948, plaintiff filed with the Tax Court of the United States in the case of *A. G. Rushlight & Co. vs. Commissioner of Internal Revenue*, Docket No. 20053, its verified petition, copies of which were served upon the Commissioner of Internal Revenue on or about August 23, 1948.

## VII.

That said petition before the Tax Court set forth in detail all of the facts, grounds, and reasons which plaintiff claimed resulted in an overassessment in its excess profits taxes for the year ending December 31, 1943, in an amount not less than \$54,218.68.

## VIII.

That during the period from August 23, 1948, to

and including August 6, 1953, plaintiff, through its representatives, officers, attorneys and accountants, conferred with representatives of the Commissioner of Internal Revenue in regard to all of the matters set forth in its said petition, which matters petitioner contended required a determination by said Commissioner of Internal Revenue that there had been an overassessment and overpayment of plaintiff's excess profits taxes for said year 1943.

### IX.

That on August 6, 1953, the Tax Court of the United States ordered that said proceeding before the Tax Court of the United States in so far as it related to petitioner's excess profits taxes for the tax year ended December 31, 1943, be dismissed for lack of jurisdiction. Plaintiff alleges that said Tax Court did not have jurisdiction over plaintiff's claim that there had been an overassessment in its excess profits taxes for said year 1943.

### X.

On or about August 28, 1953, the Commissioner of Internal Revenue determined that there was an overassessment of plaintiff's excess profits taxes for the year ended December 31, 1943, in the sum of \$65,905.29. That said determination was based upon the facts, grounds and for the reasons set forth by plaintiff in its petition before the Tax Court as heretofore alleged.

### XI.

That said R. C. Granquist, as District Director

of Internal Revenue, refunded to plaintiff the amounts of \$32,401.25, \$4,275.99 and \$593.19, being the payments made by plaintiff on account of excess profits taxes for said year 1943 on the respective dates of March 31, 1952, April 16, 1952 and November 19, 1952.

## XII.

That said Commissioner of Internal Revenue and District Director of Internal Revenue have failed, refused and neglected to refund to plaintiff the balance of said overassessment, namely, the sum of \$28,634.86.

## XIII.

On January 6, 1954, plaintiff filed with the District Director of Internal Revenue for the District of Oregon for transmission to the Commissioner of Internal Revenue an amended claim for the refund of the sum of \$66,832.82 excess profits taxes for the taxable year ending December 31, 1943, upon the ground that the petition of plaintiff before the Tax Court of the United States which was filed with the Commissioner of Internal Revenue constituted a claim for the refund of said 1943 excess profits taxes and that said petition was acted on as such by said Commissioner of Internal Revenue; and upon the further ground that all of the facts and contentions of the plaintiff which resulted in a determination by said Commissioner that there was an overassessment in said excess profits taxes were set forth in full in said petition. That on June 1, 1954, the plaintiff was given the statutory notice of the disallowance of said amended



refund claim as is provided in Section 3772(a)(2) of the Internal Revenue Code.

### Count II.

For a second and further separate claim, and in the alternative, plaintiff alleges:

#### I.

Plaintiff realleges the allegations contained in paragraphs I, II, III and IV of its first separate claim.

#### II.

That on August 23, 1948, and within the period of time allowed by law for filing claims for the refund of excess profits taxes for plaintiff's taxable year ending December 31, 1943, plaintiff caused a petition to be served on the Commissioner of Internal Revenue which petition set forth in detail the facts, grounds and reasons why the plaintiff was entitled to the refund of not less than \$54,-218.68 in excess profits taxes for the plaintiff's taxable year ending December 31, 1943, and demanded that there be refunded to plaintiff excess profits taxes which had been illegally assessed against plaintiff for the reasons set forth therein.

#### III.

That the Commissioner of Internal Revenue had under consideration the matters referred to in said petition until approximately August 28, 1953, at which time said Commissioner and plaintiff reached an account stated, and it was agreed that there

had been an overassessment and overpayment by plaintiff of excess profits taxes for the year ending December 31, 1943, in the sum of \$65,905.29.

IV.

That no part of said overassessment and overpayment has been refunded to plaintiff except the sum of \$37,270.43, and defendant has failed, refused and neglected to refund the balance of said admitted overassessment to plaintiff, and there is now due and owing to plaintiff by defendant the sum of \$28,634.86, together with interest thereon at the rate of six per cent per annum from the respective dates of the payment thereof.

Wherefore, plaintiff prays for judgment against defendant in the sum of \$28,634.86, together with interest thereon from the respective dates of the payment thereof, and for its costs and disbursements incurred herein.

/s/ DENTON G. BURDICK, JR.  
CAKE, JAUREGUY & HARDY,  
Attorneys for Plaintiff

[Endorsed]: Filed July 14, 1954.

---

[Title of District Court and Cause.]

ANSWER

Count I.

The defendant by its attorney, Clarence Edwin Luckey, United States Attorney in and for the

1954 plaintiff filed with the District Director of Internal Revenue for the District of Oregon for transmission to the Commissioner of Internal Revenue claim for refund of the sum of \$66,832.82 excess profits taxes for the taxable year ended December 31, 1943; that on June 1, 1954 plaintiff was given the statutory notice of the disallowance of said purported amended refund claim, as provided by Section 3772(a)(2) of the Internal Revenue Code; and for further affirmative answer defendant avers that no prior claim for the taxable year ended December 31, 1943 was ever filed by the plaintiff for the recovery of the taxes in question or any other tax for said year.

### Count II.

For its answer to the second and further separate claim, and in the alternative as set out in Count II the defendant states:

1. The defendant realleges its answers to allegations contained in Paragraphs I, II, III and IV of plaintiff's first separate claim.

2. Denies the allegations of Paragraph II, save and except it is admitted that on August 23, 1948 the plaintiff filed a petition with the Tax Court of the United States, as is alleged and averred in Paragraph VI of Count I of its complaint; and a copy thereof was served on the Commissioner of Internal Revenue.

3. Denies the allegations of Paragraph III, save and except it is admitted and averred that the Commissioner of Internal Revenue had under con-

sideration the petition of the plaintiff before the Tax Court until August 6, 1953, when the Tax Court ordered that said proceeding in so far as related to petitioner's excess profits taxes for the tax year ended December 31, 1943, be dismissed for lack of jurisdiction.

4. Denies the allegations of Paragraph IV, save and except it is admitted that there had been refunded to plaintiff the sum of \$37,270.43.

Wherefore, having fully answered both Counts I and II of the plaintiff's petition, the defendant prays for judgment in its favor for dismissal of plaintiff's cause of action as to each count for costs and all other proper relief.

C. E. LUCKEY,

Attorney for the Defendant, United  
States Attorney,

/s/ EDWARD J. GEORGEFF,

Assistant United States Attorney

Affidavit of Service attached.

[Endorsed]: Filed September 10, 1954.

---

[Title of District Court and Cause.]

### PRE-TRIAL ORDER

This cause came on regularly for pre-trial conference before the undersigned Judge of the above-entitled court, on the 8th day of February, 1956. Plaintiff appeared by Denton G. Burdick, Jr., one of its attorneys, and the defendant appeared

by C. E. Luckey, United States Attorney for the District of Oregon, and Edward J. Georgeff, Assistant United States Attorney for the District of Oregon.

#### Nature of the Case

The question presented in this case is whether the plaintiff is entitled to recover the balance of \$30,860.94, representing a part of an overpayment of plaintiff's excess profits tax liability for the taxable year ended December 31, 1943, in the amount of \$65,905.29. Of said overpayment, the sum of \$35,044.35 has been refunded to the plaintiff by the Commissioner.

The parties, with the approval of the court, agreed on the following:

#### Agreed Facts

##### I.

During all the times herein mentioned, the plaintiff was and is a corporation organized and existing under and by virtue of the laws of the State of Oregon, with its office and principal place of business in the City of Portland, County of Multnomah and State of Oregon. At all times herein mentioned, the defendant United States of America was and now is a corporation sovereign and a body politic, and the court has jurisdiction of this action under and by virtue of Title 28, Section 1346(a)(1), United States Code.

##### II.

James W. Maloney was, from July 17, 1933 to September 1, 1947, the Collector of Internal Revenue for the District of Oregon, and Hugh H.



Earle was, from September 1, 1947 to October 30, 1952, the Collector of Internal Revenue for the District of Oregon. At all times subsequent to October 30, 1952, R. C. Granquist has been, and now is, the District Director of Internal Revenue for the District of Oregon.

### III.

Plaintiff timely filed with the then Collector of Internal Revenue for the District of Oregon its corporation excess profits tax return for the taxable year 1943, disclosing thereon an excess profits tax liability of \$96,802.87, which amount was duly assessed by the Commissioner against the plaintiff and was paid by the latter on the dates and in the amounts as follows:

Collector or Director to whom Paid	Date of Payment	Amount of Payment
James W. Maloney.....	March 15, 1944	\$ 3,988.60
James W. Maloney.....	July 5, 1944	4,412.83
James W. Maloney.....	October 26, 1944	16,046.93
James W. Maloney.....	November 25, 1944	10,000.00
James W. Maloney.....	March 13, 1945	25,084.08
Hugh H. Earle.....	April 9, 1952	32,401.25
	by way of credit	
Hugh H. Earle.....	April 23, 1952	4,275.99
	by way of credit	
R. C. Granquist.....	November 19, 1952	593.19
	by way of credit	

### IV.

Prior to the expiration of the time prescribed in Section 275 of the Internal Revenue Code of 1939 for the assessment of excess profits taxes, the Commissioner of Internal Revenue and the plaintiff, pursuant to Section 276 (b) of said Code,

agreed in writing that excess profits taxes due from plaintiff for the year ended December 31, 1943, might be assessed at any time on or before June 30, 1949. By reason of said written agreement between the parties and the provisions of Section 322(b)(3) of the Internal Revenue Code of 1939, the time within which plaintiff might file a claim for refund of excess profits tax for the year ended December 31, 1943, was extended to December 31, 1949.

#### V.

By notice of deficiency duly mailed by the Commissioner to the plaintiff on May 28, 1948, including the explanatory statement attached thereto, the Commissioner notified plaintiff of his determination of deficiencies in its income tax liabilities for the taxable years 1943 and 1944 in the respective amounts of \$1,068.61 and \$2,262.52; of a deficiency in its excess profits tax liability for the taxable year 1944 in the amount of \$78,224.98, and of an overassessment of its excess profits tax liability for the taxable year 1943 in the amount of \$12,853.92, as shown by Pre-trial Exhibit No. 1, which is a true and correct copy of the notice of deficiency, inclusive of the explanatory statement, as aforesaid, so mailed by the Commissioner to the plaintiff on the date aforesaid. Said notice, including said explanatory statement, (Pre-trial Exhibit No. 1), is hereinafter referred to as the "notice of deficiency".

#### VI.

Said overassessment of \$12,853.92 for the taxable

year ended December 31, 1943, was arrived at by the Commissioner of Internal Revenue by certain adjustments made by him in plaintiff's net income for the years 1943 and 1945, as set forth in said notice of deficiency, as follows:

### Taxable Year Ended December 31, 1943

#### Adjustments to Net Income

Net income as disclosed by return.....		\$138,362.94
Unallowable deductions and additional income:		
(a) Partnership income increased.....	37,040.92	
(b) Sales omitted .....	378.61	
(c) Bad debts decreased .....	7,505.33	
(d) Unallowable expenses .....	12,284.81	
(e) Inventories understated .....	17,510.32	
		<hr/>
Total.....		\$213,082.93

#### Non-taxable income and additional deductions:

(f) Bonuses accrued .....	\$ 2,421.54	
(g) Depreciation increased .....	1,050.39	
(h) Net operating loss deduction .....	87,764.98	91,236.91
		<hr/>

Net income, adjusted.....\$121,846.02

### Computation of Net Loss Carry Back from Year 1945

Net income for year 1945 as disclosed by return.....\$(107,445.66)

#### Unallowable deductions and additional income:

(a) Adjustment of inventories.....	\$ 7,982.67	
(b) Unrecorded sales .....	23,573.47	
(c) Insurance on officer's life.....	1,213.92	
(d) Coos Bay option charged off.....	1,000.00	
(e) Unallowable expenses .....	7,729.46	
(f) Rents received .....	435.00	
(g) Contract income understated .....	10,754.90	
(h) Bonus Joe Sax .....	10,744.57	63,433.99
		<hr/>

        Total.....\$ (44,011.67)

Non-taxable income and additional deductions:

(i) Contracts completed in 1944.....	\$41,104.38	
(j) Additional depreciation .....	2,648.93	43,753.31

Net operating loss carry back.....\$ (87,764.98)

Said adjustments and computations above set forth, based upon the applicable tax rates for said years, resulted in the determination by the Commissioner, as stated above, that there had been an overassessment in plaintiff's 1943 excess profits tax in said sum of \$12,853.92, which said amount is the correct amount of overassessment based on the above figures.

#### VII.

On August 23, 1948, plaintiff filed with The Tax Court of the United States in the case of A. G. Rushlight & Co., an Oregon corporation, Petitioner, vs. Commissioner of Internal Revenue, Respondent, at Docket No. 20053, a verified petition relating to plaintiff's income and excess profits tax liabilities for the taxable years 1943 and 1944, two copies of which were served upon the Commissioner by the Clerk of said Tax Court, in accordance with Rule 12 of the Rules of Practice of that court. A true and correct (photostatic) copy of the petition so filed by plaintiff with said court is attached hereto and made a part hereof as Pre-trial Exhibit No. 2.

#### VIII.

On August 6, 1953, The Tax Court of the United States entered its order in the proceeding at Docket No. 20053, captioned as aforesaid, in words and figures as follows:

### “Order

“The above-entitled proceeding came on for hearing at Portland, Oregon, on July 21, 1953, on respondent’s motion to dismiss the proceeding for lack of jurisdiction insofar as relief was prayed for in connection with petitioner’s excess profits taxes for the taxable year ended December 31, 1943. The matter was argued by counsel for the parties and, it appearing that respondent did not determine a deficiency in excess profits taxes for the taxable year 1943 but did determine an overassessment for that year, the premises considered, it is

“Ordered: That the proceeding be and the same is hereby dismissed for lack of jurisdiction insofar as it relates to petitioner’s excess profits taxes for the taxable year ended December 31, 1943.”

### IX.

(a) On July 21, 1953, there was filed with The Tax Court of the United States, sitting at Portland, Oregon, in the proceeding at Docket No. 20053, as aforesaid, the written stipulation of the parties to that proceeding, in words and figures as follows:

#### “Stipulation

“It is hereby stipulated and agreed:

“(a) That there is a deficiency in Federal income tax due from this petitioner for the taxable year 1943 in the amount of \$1,647.44.

“(b) That there are deficiencies in Federal income tax, excess profits tax and penalties due from



this petitioner for the taxable year 1944, in the amounts as follows:

	Deficiency Tax	Sec. 293(a) Penalty
Income tax .....	\$ 3,972.41	\$ 143.70
Excess profits tax .....	59,264.07	3,694.62

“(c) That there is no section 293(b) penalty or section 291(a) penalty due from this petitioner for the taxable year 1944.

“It is hereby stipulated and agreed that effective upon the entry of the Court’s decision, petitioner waives the restrictions, if any, contained in the applicable sections of the Internal Revenue Code and amendments thereto, upon the assessment and collection of said deficiencies in tax and penalties, plus interest as provided by law.

“It is further stipulated and agreed that the Court may deny petitioner’s prayer for relief as contained in paragraph (a) of the petition herein, relating to excess profits tax for the taxable year 1943, on the ground that the Court is without jurisdiction thereof by reason of the fact that the Commissioner has not determined a deficiency in petitioner’s excess profits tax for that taxable year.” (The phrase “paragraph (a) of the petition herein”, as contained in the last quoted paragraph, refers to paragraph (a) of plaintiff’s prayer for relief appearing on page 17 of its petition so filed with the Tax Court on July 21, 1953. (See Pre-trial Exhibit No. 2.))

(b) On August 6, 1953, The Tax Court of the United States entered its decision in the proceeding

at Docket No. 20053, as aforesaid, in words and figures as follows:

“Decision

“That there is a deficiency in income tax for the taxable year 1943, in the amount of \$1,647.44; that there are deficiencies in income tax, excess profits tax, and penalties due for the taxable year 1944, in the amounts as follows:

	Deficiency in Tax	Sec. 293(a) Penalty
Income tax .....	\$ 3,972.41	\$ 143.70
Excess profits tax .....	59,264.07	3,694.62

That there is no section 293(b) penalty or section 291(a) penalty due for the taxable year 1944.”

Said decision became final on November 6, 1953.

X.

The deficiencies in income tax and excess profits tax and penalties as shown by the stipulation of the parties, referred to in paragraph IX(a), above, and by the decision of the Tax Court, referred to in paragraph IX (b), above, were and are the consequence of various income and expense adjustments and/or other changes agreed upon by and between the plaintiff and the Commissioner, as a result of the negotiations hereinafter referred to, between the plaintiff and the Commissioner, the latter acting through his then Technical Staff, as was and is also the overassessment and overpayment of plaintiff's excess profits tax liability for the taxable year 1943 in the amount of \$65,905.29, as aforesaid.

Based upon the income and/or other adjustments

so agreed upon and made, as aforesaid, the plaintiff and the Commissioner agreed that there was an overassessment and overpayment of excess profits tax for the taxable year 1943 of \$65,905.29, as shown in agreement entered into by the plaintiff and the Commissioner on August 28, 1953, referred to in paragraph XI (i) of this Pre-trial Order, as Pre-trial Exhibit No. 3.

### XI.

The adjustments referred to in paragraph X, above, were made in respect of the Commissioner's determinations as set forth in the notice of deficiency (Pre-trial Exhibit No. 1). The following schedule shows (1) the adjustment items appearing in the notice of deficiency in respect of which changes were made in arriving at the aforesaid agreed upon deficiencies and overpayment; (2) the allegations in plaintiff's Tax Court petition concerning the same, and (3) the action taken by the Commissioner thereon:

[Note: Adjustment Items, Plaintiff's Allegations and Action of Commissioner Thereon for Years 1943 and 1945 are set out at pages 51-63 of this printed record except paragraph (i) which is set out below.]

(i) The adjustments and/or changes described in subparagraphs (a) to (h), inclusive, of this paragraph, are the adjustments and/or changes referred to in paragraph X, above, which resulted, inter alia, in the overassessment and overpayment of excess profits tax of \$65,905.29 for the year 1943, as set forth in paragraph X, above. Pre-trial Exhibit No.

3 is a true and correct copy of an agreement entered into between the plaintiff and the Commissioner on August 28, 1953, relating to said over-assessment and overpayment of excess profits tax of \$65,905.29 for the year 1943.

## XII.

(a) On line 38 of its income and declared value excess profits tax return for the year 1945, plaintiff reported an adjusted net loss of \$107,445.66. In computing the said loss of that amount, the plaintiff reported as income the sum of \$42,789.78 as representing the total amount of profit derived by it during that year from two contracts performed by it for Oregon Shipyards. In the notice of deficiency, the Commissioner determined that of the income of \$42,789.78, so reported by plaintiff for the year 1945, the sum of \$41,104.38 should have been reported as income derived by it from said contracts during the year 1944. In its Tax Court petition, as aforesaid, plaintiff assigned error in respect of the Commissioner's determination, as set forth in this subparagraph, in words and figures as follows:

“(f) Respondent erred in his determination that gain on completed contracts of petitioner should be reallocated as to taxable years as follows:

“Year ended December 31, 1944, increase in income, \$41,104.58.

“Year ended December 31, 1945, decrease in income, \$41,104.58.”

In arriving at the deficiencies in income tax and

excess profits tax for the year 1944 in the respective amounts of \$3,972.41 and \$59,264.07, as shown by the stipulation of the parties and the decision of the Tax Court entered pursuant thereto, as set forth in paragraph IX (a) and (b), above, no adjustment or change was made with respect to the Commissioner's determination as to the treatment of the profit derived by plaintiff from the two Oregon Shipyards contracts referred to in this subparagraph.

(b) In arriving (1) at the deficiency in income tax for the year 1943 in the amount of \$1,647.44, as shown in the stipulation of the parties and the decision of the Tax Court entered pursuant thereto, as set forth in paragraph IX (a) and (b), above, and (2) at the overassessment and overpayment of excess profits tax for that taxable year of \$65,905.29, referred to on page 1 and paragraph XI (i), pages 13 and 14, above, the Commissioner determined and allowed as a deduction for that taxable year a net operating loss carry-back from the year 1945 in the amount of \$108,805.33. In the computation of said net operating loss carry-back of \$108,805.33, no adjustment or change was made with respect to the Commissioner's determination as to the treatment of the profit derived by plaintiff from the two Oregon Shipyards contracts referred to in subparagraph (a), above.

### XIII.

(a) Plaintiff reported an excess profits tax liability of \$96,802.87 on its excess profits tax return



for the taxable year 1943. If the \$41,104.38 profit derived from the Oregon Shipyards contracts, referred to in paragraph XII, above, had been reported by plaintiff on its return for the year 1944, instead of the year 1945, as aforesaid, and no adjustment of income otherwise reported by plaintiff, either in the year 1943 or 1945, had been made by the Commissioner, then and in that event the excess profits tax liability as reported on plaintiff's return for the year 1943, computed on that basis, would have been \$67,207.72, instead of \$96,802.87, as aforesaid; and the overpayment for that year would have been \$36,310.14, instead of \$65,905.29, as aforesaid.

(b) If, in addition to the various income and expense adjustments and/or other changes referred to in paragraphs X and XI, above, the Oregon Shipyards contracts item of \$41,104.38 had, as a result of the negotiations referred to in those paragraphs, been treated as income includible in plaintiff's taxable income for the year 1945, instead of the year 1944, as aforesaid, then and in that event the excess profits tax liability of plaintiff for the taxable year 1943, computed on that basis, would have been \$64,879.99, instead of \$96,802.87, as aforesaid; and the overpayment for that year would have been \$31,902.88, instead of \$65,905.29, as aforesaid.

(c) Of the deficiency in excess profits tax for the taxable year 1944 in the amount of \$59,264.07, referred to in paragraph IX (a) and (b), above,

the sum of \$35,144.25 is attributable to the \$41,104.38 Oregon Shipyards contracts item adjustment referred to in paragraph XII (a) and (b), above.

(d) Attached hereto and made a part hereof as Pre-trial Exhibit No. 4 is a true and correct (photostat) copy of the "Audit Statement", consisting of 32 pages, prepared in the Portland, Oregon, office of the Appellate Division, Internal Revenue Service, during the month of August 1953, for the purpose of giving effect to the various agreed upon income and expense adjustments and/or the changes referred to and discussed in paragraphs X, XI and XII, above. This pre-trial exhibit (No. 4) represents and is the computation by which effect was given to said agreed upon adjustments, resulting in (1) the deficiencies in income tax and excess profits tax and penalties as shown by the stipulation of the parties, referred to in paragraph IX (a), above, and by the decision of the Tax Court, referred to in paragraph IX (b), above, and (2) in the overassessment and overpayment of excess profits tax for the year 1943 in the amount of \$65,905.29, hereinabove referred to. This Pre-trial Exhibit No. 4 is the document referred to as an "audit statement" in plaintiff's claim for refund for the year 1943, filed on January 5, 1954, a copy of which claim for refund has been made a part of this Pre-trial Order as Pre-trial Exhibit No. 5.

#### XIV.

Plaintiff's Tax Court petition, filed, as stated in paragraph VII, above, on August 23, 1948, together

with the file in said case, was, by the Commissioner of Internal Revenue, transmitted to the Portland, Oregon, office of the then Technical Staff of the Treasury Department of the United States on September 9, 1948. At the same time, the Commissioner transmitted to said Technical Staff certain petitions and files in regard to the following related docketed and nondocketed cases for the taxpayers and years shown:

Docketed Tax Court Cases	Years
Juanita Investment Company vs. Commissioner of Internal Revenue, Docket No. 20020.....	1942, 1944
Juanita R. Leggett vs. Commissioner of Internal Revenue, Docket No. 20021 .....	1943
W. A. Rushlight and Betty Rushlight vs. Commissioner of Internal Revenue, Docket No. 20022.....	1944
W. A. Rushlight vs. Commissioner of Internal Revenue, Docket No. 20023 .....	1943
 Nondocketed Cases	
Raymond Rushlight .....	1943
Betty Rushlight .....	1943

In connection with all of said cases, including plaintiff's case, the taxpayers at all times between September 12, 1947 and August 24, 1951, were represented by Eric Van, a certified public accountant, and at all times between September 12, 1947 and December 2, 1950, by Carl E. Davidson, a lawyer, both of whom were admitted to practice before the Treasury Department. Meetings were held between said two representatives of plaintiff and representatives of the Technical Staff, Treasury Department, Portland, Oregon, sometimes both representatives of plaintiff being present and sometimes one only, on the following dates: November

4, 1948; January 14, 1949; May 24, 1949; August 22, 1949, and October 3, 1949; and thereafter, almost daily until about December 5, 1949. Thereafter, similar conferences were held as follows: In the year 1950, on February 10, April 3, May 9, July 5, September 7, September 30, October 13, December 1 and December 12; in the year 1951, on March 10, April 19, April 27, May 10 and June 22. Between June 22, 1951 and April 16, 1952, discussions continued between members of the Technical Staff and one of the officers of plaintiff as to items of gross income and deduction affecting all of the above cases. Commencing in June, 1953, a series of similar conferences were held with the substituted counsel for plaintiff and said other taxpayers. These conferences culminated, on or about July 21, 1953, in the settlement of all of the cases mentioned above, including plaintiff's case, which said settlement included the resulting overpayment for the year 1943, in the sum of \$65,905.29, referred to hereinabove.

#### XV.

Of the above sum of \$65,905.29, overpayment by plaintiff, there was refunded to plaintiff the amount of \$35,044.35, this refund being made on November 8, 1953, by R. C. Granquist, District Director of Internal Revenue, said amount being the total of the payments made by plaintiff by way of credit on account of its 1943 excess profits tax assessment in the sums of \$32,401.25 on April 9, 1952, \$4,275.99 on April 23, 1952, and \$593.19 on November 19, 1952, less the sum of \$2,226.08. That said sum of



\$2,226.08 represents interest from March 15, 1944 to March 15, 1946, on the sum of \$18,550.66, which was the amount of deficiency in plaintiff's 1943 excess profits tax prior to the application thereto of the carry-back loss from the year 1945.

#### XVI.

The Commissioner of Internal Revenue and the District Director of Internal Revenue have failed and refused to refund to plaintiff the balance of said overpayments, namely, the sum of \$30,860.94.

#### XVII.

On January 5, 1954, plaintiff filed with the Commissioner and/or the District Director, Internal Revenue Service, Portland, Oregon, a claim for refund of excess profits tax for the year 1943 in the amount of \$66,832.82, "or such other amount as is legally refundable", a true and correct (photostat) copy of which is attached hereto and made a part hereof as Pre-trial Exhibit No. 5. By letter dated April 20, 1954 a true and correct (photostat) copy of which is attached hereto and made a part hereof as Pre-trial Exhibit No. 6, said Commissioner and/or District Director advised plaintiff, in substance, that said claim for refund would be disallowed in full; and by registered letter dated June 1, 1954 a true and correct (photostat) copy of which is attached hereto and made a part hereof as Pre-trial Exhibit No. 7, said Commissioner and/or District Director notified plaintiff, in the manner as provided by Section 3772(a)(2) of



the Internal Revenue Code of 1939, that said claim was thereby so disallowed.

### XVIII.

On November 12, 1953, the deficiencies in income tax, excess profits tax and penalties for the years 1943 and 1944, as shown by the stipulation of the parties, referred to in paragraph IX (a), above, and by the decision of the Tax Court, referred to in paragraph IX (b), above, were assessed against plaintiff by the Commissioner in accordance with the provisions of Section 272(b) of the Internal Revenue Code of 1939.

### Plaintiff's Contentions

#### I.

That its petition in the Tax Court referred to in paragraphs VII and VIII constituted a claim for the refund of the balance of the agreed overpayment, both within the meaning of Section 322 of the Internal Revenue Code and the regulations of the Treasury Department promulgated thereunder, and also under Section 3771(e) of the Internal Revenue Code; and that plaintiff is entitled to judgment against the defendant in the sum of \$30,860.94, together with interest thereon at the rate of 6% per annum from August 23, 1948, to November 12, 1953; and plaintiff is also entitled to interest at 6% per annum on the following sums heretofore paid plaintiff (by way of credit) from the dates of payments by plaintiff to the dates of repayment to plaintiff, that is to say, on the sum

of \$32,401.25 from April 9, 1952 to November 12, 1953; on the sum of \$4,275.99 from April 23, 1952 to November 12, 1953; and on the sum of \$593.19 from November 19, 1952 to November 12, 1953.

## II.

That in acting upon and investigating the claim in plaintiff's Tax Court petition, in which it was alleged that there was an overassessment in plaintiff's 1943 excess profits tax returns, the Commissioner of Internal Revenue waived any requirement that plaintiff file any other or different claim for refund than that included in plaintiff's said petition, and plaintiff is entitled to judgment for the amounts set forth in Contention No. 1.

## III.

Independently of the above contentions, plaintiff contends that its petition in the Tax Court constituted a demand on the Commissioner of Internal Revenue that there be refunded to plaintiff excess profits taxes which had been illegally assessed and collected from it for the reasons set forth in said petition. That the Commissioner of Internal Revenue had under consideration all of the matters referred to in said petition until approximately July 21, 1953, at which time the plaintiff and the Commissioner reached an account stated, and it was agreed that there had been an overassessment and overpayment of excess profits taxes for the year ending December 31, 1943, in the sum of \$65,905.29. That no portion of said sum had

December 31, 1943, within the provisions of Section 322 of the Internal Revenue Code of 1939 and as required by Section 3772 of the Internal Revenue Code of 1939.

## II.

Defendant contends that the Commissioner of Internal Revenue and/or his officers or agents have not by their actions waived the requirement of the filing of a proper claim for refund.

## III.

Defendant contends that the Commissioner of Internal Revenue and the plaintiff did not on or about July 21, 1953, nor at any time, reach an account stated in respect to the overassessment or overpayment of excess profits taxes for the year ended December 31, 1943.

## IV.

Defendant contends that the decision of the Tax Court did not render Section 3801 of the Internal Revenue Code of 1939 applicable.

## V.

Defendant contends that it should not be required to apply any part of the overassessment or overpayment of excess profits taxes for the year ended December 31, 1943, not heretofore refunded to plaintiff, to unpaid deficiencies in plaintiff's excess profits taxes for the year ended December 31, 1944.

## VI.

Defendant contends that the Commissioner of

Internal Revenue properly applied \$2,226.08 of the overassessment and overpayment of excess profits taxes for the year ended December 31, 1943, as interest on the unassessed deficiency of excess profits taxes for the period from March 15, 1944 to March 15, 1946.

Issues

I.

Did plaintiff's Tax Court petition constitute a proper claim for refund under the provisions of Sections 322, 3771(e) and 3772 of the Internal Revenue Code of 1939?

II.

Did the agreement between plaintiff and defendant dated August 28, 1953, constitute an account stated?

III.

Did defendant waive the requirement that a claim for refund be filed?

IV.

Was the time for filing a claim for refund extended by reason of the decision of the Tax Court and Section 3801 of the Internal Revenue Code of 1939 with respect to plaintiff's overassessment and overpayment of its excess profits taxes for its year ended December 31, 1943?

V.

Is plaintiff entitled to have any portion of the overassessment and overpayment in its 1943 excess profits taxes set off against the unpaid deficiency in its 1944 excess profits taxes?

## VI.

In any event did the Commissioner of Internal Revenue properly reduce the amount otherwise determined to be refundable by him by the amount of \$2,226.08, being the interest on the unassessed deficiency in plaintiff's 1943 excess profits taxes?

## Exhibits

The following exhibits are below enumerated and identified. No further identification of these exhibits will be required, and it is stipulated between the parties that the documents are authentic and in the case of copies that they are true copies of the original, and that said exhibits shall be admitted without objection except as to irrelevancy:

1. Notice of deficiency dated May 28, 1948.
2. Petition in Tax Court.
3. Agreement between plaintiff and defendant as to amount of overassessment, dated August 28, 1953.
4. Audit statement.
5. Claim for refund dated December 29, 1953.
6. Letter dated April 20, 1954.
7. Letter dated June 1, 1954.

It Is Hereby Ordered, Considered and Adjudged that all pleadings herein shall be amended to conform to this pre-trial order and that this order shall supersede said pleadings and set forth all issues in this action. This pre-trial order shall not be amended except by consent, or to prevent manifest injustice.



Dated this 8th day of February, 1956.

/s/ CHASE A. CLARK,  
District Judge

Approved:

/s/ DENTON G. BURDICK, JR.,  
Of Attorneys for Plaintiff

/s/ EDWARD J. GEORGEFF,  
Of Attorneys for Defendant

[Endorsed]: Filed February 8, 1956.

---

[Title of District Court and Cause.]

### OPINION

Hutchinson, Schwab and Burdick, Denton G. Burdick, Jr., Portland, Oregon, Attorneys for Plaintiff.

Charles K. Rice, Assistant Attorney General, Andrew D. Sharpe, Allan A. Bowden, David R. Frazer, Attorneys, Dept. of Justice, Washington, D. C., C. E. Luckey, United States Attorney for Oregon, Edward J. Georgeff, Assistant United States Attorney for Oregon, Portland, Oregon, Attorneys for Defendant.

Clark, D. J.

The taxpayer, A. G. Rushlight & Co., timely filed with the Collector of Internal Revenue for the District of Oregon, its corporation excess profits tax return for the year 1943 showing a liability of \$96,802.87.

This amount was duly paid or credited against

outstanding taxes for other years and waivers were timely filed extending the assessment period to June 30, 1949. By reason of these waivers and the provisions of Section 322 (b)(3) of the Internal Revenue Code of 1939, the time for filing a refund claim for the year 1943 was extended for six months to December 31, 1949.

On May 28, 1948, the taxpayer was sent the statutory notice showing an income tax deficiency and an excess profits tax overassessment for 1943 and income tax and excess profits tax deficiencies for 1944.

August 23, 1948, the taxpayer filed a petition with the Tax Court for redetermination as to all of these matters. Various negotiations continued and were pending for the following five years. In 1953, on stipulation of the parties, the Tax Court dismissed the petition as it pertained to redetermination of the overassessment on the grounds that it lacked jurisdiction.

On July 5, 1954, the taxpayer filed a formal claim for refund for 1943 excess profits taxes, alleging that the petition filed with the Tax Court was an informal refund claim, subject to amendment, and this claim as filed was such an amendment. On June 1, 1954, this claim for refund was rejected by the Commissioner, whereupon this suit was instituted by A. G. Rushlight and Co., taxpayer. This is only a brief summary of the facts the Court feels are most pertinent to its decision.

It is the government's contention that the petition filed with the Tax Court for the redetermina-

tion of 1943 and 1944 income tax deficiencies and 1943 excess profits tax overassessment cannot qualify as an informal claim for refund.

Sec. 322(b)(1) I.R.C. 1939 (26 U.S.C. 1952 ed., Sec. 322) provides that a claim for refund must be filed by the taxpayer within three years from the time the return was filed or within two years from the time the tax was paid and provision is also made for an extension of six months, which extension was made in this case.

Regulations 111, Sec. 29, 322-3, provides that the claim for refund shall be made on Form 843 and filed with the Collector of Internal Revenue. It is these regulations that the government contends have not been complied with during the statutory period and therefore, plaintiff cannot recover.

The taxpayer contends that its petition filed with the Tax Court within the statutory period, served as an informal claim which was perfected by the filing of the formal claim on January 5, 1954.

The Government concedes that if the taxpayer files an informal claim for refund with the Commissioner in writing, it may be sufficient to stay the statutory period within which a formal refund claim may be filed.

The regulations provide that the claim for refund should "set forth in detail and under oath each ground upon which a refund is claimed, and facts sufficient to apprise the Commissioner of the exact basis thereof." In the case of *Smale and Robinson, Inc. vs. U. S.*, 123 F. Supp. 457 at 470

the Court, quoting Judge Prettyman in *Keneipp vs. U. S.*, 184 F.2d 263 at 267, said:

“Claim for refund of federal excise profits taxes paid must be sufficient to advise the Commissioner of Internal Revenue as to items as to which taxpayer claims error and grounds upon which taxpayer makes his claim and if Commissioner understands grounds and deals with claim on basis of his understanding, claim is sufficient. A broad public policy is involved in this broad doctrine. Insistence upon nice technicalities of expression on the part of taxpayers in dealings with the Government concerning taxes must certainly compel taxpayers to deal with the Government through technicians. The Bureau of Internal Revenue has long sought to encourage a direct informal and non-technical presentation.”

Certainly the petition filed gave sufficient notice and set forth the claim adequately.

It seems to be the government's theory that, while the petition might have served as an informal claim, if filed with the Commissioner, it did not because it was filed with the Tax Court; the former being an administrative agency under the executive branch of the Government and the latter coming under the judiciary branch. This might be a general rule, but the facts of each individual case should determine its particular status.

The letter of May 28, 1948, advising the taxpayer of deficiencies in income tax for 1943 and 1944, and the overassessment on excess profits tax

for 1943, with which we are here concerned, is, in this Court's opinion, ambiguous and misleading as to what steps the taxpayer should take.

Conspicuously attached to the front of the letter is a notice advising the taxpayer that if he decides to initiate a proceeding before the Tax Court, for a redetermination of deficiency he must do so within ninety days by filing the same with the Tax Court in Washington. The notice then says that under no circumstances should a petition for redetermination be forwarded to the Commissioner or Collector of Internal Revenue.

The letter itself continues on and says "Should you not desire to file a petition, you are requested to execute the enclosed form and forward it to the Internal Revenue Agent in charge, Seattle, Washington." The taxpayer is also advised that the signing of this form will expedite the closing of their returns.

The statement, also enclosed with the letter, states:

"The overassessment shown herein will be made the subject of a certificate of overassessment which will reach you in due course, \* \* \* and will be applied \* \* \* provided that you fully protect yourself against the running of the statute of limitations \* \* \* by filing with the collector of internal revenue for your district, a claim for refund on Form 843, a copy of which is enclosed \* \* \*".

This Court feels no amazement, taking into consideration all this correspondence—*notices, letters,*



statements, etc.,—that this taxpayer failed to execute the claim for refund relating to the over-assessment and file the same with the local collector, but rather filed a petition with the Tax Court for redetermination of all of the Commissioner's findings.

The other happenings which the Court feels are pertinent are (1) the Tax Court served two copies of the petition on the Commissioner who thereupon forwarded same to the Portland office; and (2) Whether as a result of that petition or not, the Commissioner did, over a period of years, investigate the matters set forth in the petition, as though it were a claim for refund. When the amount of the overassessment and overpayment was agreed upon in 1953, it was then discovered that the Plaintiff had not filed Form 843. The taxpayer then executed said Form as an Amended Claim for Refund.

The Court can understand that in the event a petition, even though adequate for an informal claim for refund, was filed with the Tax Court but never reached the Commissioner, the Commissioner would have no notice and the statutory and regulatory provisions would not have been fulfilled. However, such is not the case here. The petition, along with other allegations, sets forth the matters relating to the overassessment and overpayment and, the Court feels, may be considered as an informal claim for refund.

Further, although not filed with the Commissioner, it reached his hands and the Court considers

this adequate, under the facts as set forth herein, to meet all the requirements. This Claim was perfected by the Amended Claim, filed on Form 843, after the statute of limitations had run.

While not complying with all the technicalities of the Regulations, the taxpayer acted in good faith, and while he perhaps erred technically, still the end purpose was accomplished. Good conscience will not permit this Court to penalize the taxpayer in such a situation. Therefore, the taxpayer is entitled to recover the balance of \$30,860.94, representing a part of an overpayment of excess profits tax liability for 1943, the remainder of which has been refunded.

Counsel for Plaintiff may prepare Findings of Fact, Conclusions of Law and Judgment in accordance herewith, submitting the original to the Court and serving a copy on opposing counsel.

[Endorsed]: Filed August 31, 1956.

---

[Title of District Court and Cause.]

### NOTICE OF APPEAL

To: A. G. Rushlight & Co., an Oregon corporation, Plaintiff, and Hutchinson, Schwab and Burdick; Denton G. Burdick, Jr., Attorneys for Plaintiff, 420 Equitable Building, Portland 4, Oregon:

Notice is hereby given that the United States of America, defendant above-named, hereby appeals to the United States Court of Appeals for the Ninth Circuit from the judgment contained in the

opinion of Chase A. Clark, United States District Judge, filed in the within action and docketed on August 31, 1956, in favor of plaintiff and against defendant.

Dated October 29, 1956, at Portland, Oregon.

C. E. LUCKEY,

United States Attorney, District of  
Oregon

/s/ EDWARD J. GEORGEFF,

Assistant United States Attorney,  
Of Attorneys for Defendant

[Endorsed]: Filed October 29, 1956.

---

[Title of District Court and Cause.]

#### ORDER

This matter coming on to be heard ex parte upon motion of defendant for an order extending time for the filing of the record on appeal and docketing the within action in the United States Court of Appeals for the Ninth Circuit, to enable The Solicitor General to have additional time to consider said appeal, and the Court being fully advised in the premises,

It Is Ordered that the time for filing the record on appeal and docketing the within action be and it is hereby extended to ninety days from October 29, 1956, the date of filing of the Notice of Appeal.

Dated this 5th day of December, 1956.

/s/ CHASE A. CLARK,

Judge

[Endorsed]: Filed December 6, 1956.

[Title of District Court and Cause.]

## FINDINGS OF FACT AND CONCLUSIONS OF LAW

This action came on for trial before the court on the pre-trial order heretofore entered, the testimony adduced by the parties, and the exhibits introduced at the trial, plaintiff appearing by Denton G. Burdick, Jr., one of its attorneys, and the defendant appearing by Allen Bowden, attorney, Department of Justice, and Edward J. Georgeff, Assistant United States Attorney for the District of Oregon. The court having considered said pre-trial order and the agreed facts therein contained, the testimony and exhibits introduced at the trial, and the briefs of counsel, and having previously rendered its opinion herein, and being full advised in the premises, makes the following

### Findings of Fact

#### I.

Plaintiff was and is a corporation organized and existing under and by virtue of the laws of the State of Oregon, with its office and principal place of business in the City of Portland, County of Multnomah and State of Oregon. The defendant United States of America was and now is a corporation sovereign and a body politic.

#### II.

James W. Maloney was, from July 17, 1933 to September 1, 1947, the Collector of Internal Rev-

enue for the District of Oregon, and Hugh H. Earle was, from September 1, 1947 to October 30, 1952, the Collector of Internal Revenue for the District of Oregon. At all times subsequent to October 30, 1952, R. C. Granquist has been, and now is, the District Director of Internal Revenue for the District of Oregon.

### III.

Plaintiff timely filed with the then Collector of Internal Revenue for the District of Oregon its corporation excess profits tax return for the taxable year 1943, disclosing thereon an excess profits tax liability of \$96,802.87, which amount was duly assessed by the Commissioner against the plaintiff and was paid by the latter on the dates and in the amounts as follows:

Collector or Director to whom Paid	Date of Payment	Amount of Payment
James W. Maloney.....	March 15, 1944	\$ 3,988.60
James W. Maloney.....	July 5, 1944	4,412.83
James W. Maloney.....	October 26, 1944	16,046.93
James W. Maloney.....	November 25, 1944	10,000.00
James W. Maloney.....	March 13, 1945	25,084.08
Hugh H. Earle.....	April 9, 1952	32,401.25
	By way of credit	
Hugh H. Earle.....	April 23, 1952	4,275.99
	By way of credit	
R. C. Granquist.....	November 19, 1952	593.19
	By way of credit	

### IV.

Prior to the expiration of the time prescribed in Section 275 of the Internal Revenue Code of 1939 for the assessment of excess profits taxes, the Commissioner of Internal Revenue and the plaintiff,



pursuant to §276 (b) of said Code, agreed in writing that excess profits taxes due from plaintiff for the year ended December 31, 1943, might be assessed at any time on or before June 30, 1949. By reason of said written agreement between the parties and the provisions of §322 (b)(3) of the Internal Revenue Code of 1939, the time within which plaintiff might file a claim for refund of excess profits tax for the year ended December 31, 1943, was extended to December 31, 1949.

#### V.

By notice of deficiency duly mailed by the Commissioner to the plaintiff on May 28, 1948, including the explanatory statement attached thereto, the Commissioner notified plaintiff of his determination of deficiencies in its income tax liabilities for the taxable years 1943 and 1944 in the respective amounts of \$1,068.61 and \$2,262.52; of a deficiency in its excess profits tax liability for the taxable year 1944 in the amount of \$78,224.98, and of an over-assessment of its excess profits tax liability for the taxable year 1943 in the amount of \$12,853.92.

#### VI.

Said overassessment of \$12,853.92 for the taxable year ended December 31, 1943, was arrived at by the Commissioner of Internal Revenue by certain adjustments made by him in plaintiff's net income for the years 1943 and 1945, as set forth in said notice of deficiency, as follows:

## Taxable Year Ended December 31, 1943

## Adjustments to Net Income

Net income as disclosed by return.....		\$138,362.94
Unallowable deductions and additional income:		
(a) Partnership income increased.....	37,040.92	
(b) Sales omitted .....	378.61	
(c) Bad debts decreased .....	7,505.33	
(d) Unallowable expenses .....	12,284.81	
(e) Inventories understated .....	17,510.32	
	<hr/>	
Total.....		\$213,082.93
Non-taxable income and additional deductions:		
(f) Bonuses accrued .....	\$ 2,421.54	
(g) Depreciation increased .....	1,050.39	
(h) Net operating loss deduction .....	87,764.98	91,236.91
	<hr/>	<hr/>
Net income, adjusted.....		\$121,846.02

Computation of Net Loss Carry Back  
from Year 1945

Net income for year 1945 as disclosed by return.....		\$(107,445.66)
Unallowable deductions and additional income:		
(a) Adjustment of inventories.....	\$ 7,982.67	
(b) Unrecorded sales .....	23,573.47	
(c) Insurance on officer's life.....	1,213.92	
(d) Coos Bay option charged off.....	1,000.00	
(e) Unallowable expenses .....	7,729.46	
(f) Rents received .....	435.00	
(g) Contract income understated .....	10,754.90	
(h) Bonus Joe Sax .....	10,744.57	63,433.99
	<hr/>	<hr/>
Total.....		\$ (44,011.67)
Non-taxable income and additional deductions:		
(i) Contracts completed in 1944.....	\$41,104.38	
(j) Additional depreciation .....	2,648.93	43,753.31
	<hr/>	<hr/>
Net operating loss carry back.....		\$ (87,764.98)

Said adjustments and computations above set forth, based upon the applicable tax rates for said years,

resulted in the determination by the Commissioner, as stated above, that there had been an overassessment in plaintiff's 1943 excess profits tax in the sum of \$12,853.92, which said amount is the correct amount of overassessment based on the above figures.

## VII.

On August 23, 1948, plaintiff filed with The Tax Court of the United States in the case of *A. G. Rushlight & Co.*, an Oregon corporation, Petitioner, vs. Commissioner of Internal Revenue, Respondent, at Docket No. 20053, a verified petition relating to plaintiff's income and excess profits tax liabilities for the taxable years 1943 and 1944, two copies of which were served upon the Commissioner by the Clerk of said Tax Court, in accordance with Rule 12 of the Rules of Practice of that court.

In addition to the allegations set forth in paragraph XI of these findings, said petition contained the following allegations:

“(k) Respondent erred in his determination that there is an overassessment of only \$12,853.92 in petitioners excess profits tax for the taxable year ended December 31, 1943, and in failing and refusing to find that there was an overassessment of not less than \$54,218.68 in petitioner's excess profits tax for such year.”

“(a) That there is an over-assessment in petitioner's excess profits tax for the taxable year ended December 31, 1943 of not less than \$54,218.68 for said year;”

## VIII.

On August 6, 1953, The Tax Court of the United States entered its order in the proceedings at Docket No. 20053, dismissing the proceedings insofar as they related to the plaintiff's excess profits taxes for the taxable year ended December 31, 1943.

## IX.

On July 21, 1953, the parties to the proceeding in The Tax Court of the United States, in the proceeding at Docket No. 20053, stipulated that there was a deficiency in federal income tax due from plaintiff for the taxable year 1943 in the amount of \$1,647.44, and that there was deficiencies in federal income tax, excess profits tax and penalties due from plaintiff for the taxable year 1944 as follows:

	Deficiency Tax	Sec. 293(a) Penalty
Income tax .....	\$ 3,972.41	\$ 143.70
Excess Profits tax.....	59,264.07	3,694.62

On August 6, 1953, The Tax Court of the United States entered its decision in the proceeding at Docket No. 20053 that there were deficiencies due from plaintiff in said amounts. Said decision became final on November 6, 1953.

## X.

The deficiencies in income tax and excess profits tax and penalties stipulated by plaintiff and the Commissioner and incorporated in the decision of the Tax Court were and are the consequence of various income and expense adjustments and/or other changes agreed upon by and between the

plaintiff and the Commissioner, as a result of negotiations between the plaintiff and the Commissioner, the latter acting through his then Technical Staff, as was and is also the overassessment and overpayment of plaintiff's excess profits tax liability for the taxable year 1943 in the amount of \$65,905.29 as hereinafter found.

Based upon the income and/or other adjustments so agreed upon and made, the plaintiff and the Commissioner agreed that there was an overassessment and overpayment of excess profits tax for the taxable year 1943 of \$65,905.29, and on August 28, 1953, plaintiff and the Commissioner entered into an agreement in writing to that effect.

## XI.

The adjustments referred to in paragraph X above were made in respect of the Commissioner's determinations as set forth in the notice of deficiency. The following schedule shows (1) the adjustment items appearing in the notice of deficiency in respect of which changes were made in arriving at the aforesaid agreed upon deficiencies and overpayment; (2) the allegations in plaintiff's Tax Court petition concerning the same, and (3) the action taken by the Commissioner thereon:

### Year 1943

(a) Partnership income increased (per deficiency notice) \$37,040.92.

#### Allegations in Tax Court Petition:

“(a) The Commissioner of Internal Revenue, hereinafter called ‘respondent’, erred in his de-



termination that partnership income of petitioner should be increased in the following amounts:

Taxable year ended December 31, 1943, \$37,040.92 and in failing and refusing to find that petitioner properly reported its income from partnerships (joint ventures).

“(a-1) As stated in his notice of deficiency, the amounts comprising the item of partnership income erroneously added to income by the respondent are as follows:

Year ended December 31, 1943:

Waale-Camplin Co. ....	\$ 34,269.36
Defense Construction Co. ....	2,771.56

Total .....	\$ 37,040.92
-------------	--------------

“(a-2) On December 23, 1942 and January 18, 1943, the petitioner and W. A. Rushlight Company, a partnership, and others entered into joint venture agreements with the Waale-Camplin Co. covering two contracts in connection with housing construction for the Vancouver Housing Authority.

“(a-3) Such joint ventures were managed by the Waale-Camplin Co., all parties to profit, or assume losses in the proportion to their capital contributions to the venture, after allowance of management compensation to the Waale-Camplin Co.

“(a-4) The capital contribution to the venture made by the A. G. Rushlight & Co. and the W. A. Rushlight Company was made jointly from borrowed funds. Said funds were borrowed in the name of the A. G. Rushlight & Co. but the said W. A.

Rushlight Company, through its partners, were also guarantors of said loans.

“(a-5) The earnings of the venture for the year ended December 31, 1943, attributable to the joint venture interest of petitioner were \$34,269.37, and were included in its books and tax returns for the said year.

“(a-6) In his examination of petitioner’s returns for that year, respondent has arbitrarily and erroneously added to petitioner’s income the share of income from said joint venture attributable to the joint venture interest of the partnership W. A. Rushlight Company.”

#### Action by Commissioner:

(a) As a result of the negotiations referred to in paragraph X above, the Commissioner conceded the plaintiff’s contention that the item of \$34,269.36 was not income of the plaintiff for the year 1943 and that said amount had been erroneously added to its income for that year in the notice of deficiency. Plaintiff’s excess profits net income for the year 1943, as shown by the notice of deficiency, was accordingly decreased by that amount.

(b) Bad debts decreased (per notice of deficiency) \$7,505.33.

#### Allegations in Tax Court Petition:

“(d) Respondent erred in his determination that the bad debts claimed by petitioner in its returns for the taxable year ended December 31, 1943, should be decreased by \$7,505.33; and in failing and refusing to hold that the bad debts claimed by peti-

tioner in said returns should be decreased by no more than \$1,750.00.

\* \* \* \* \*

“(d) During the year ended December 31, 1942, petitioner advanced funds, in connection with the development of a manganese property by the Manganese Mining and Manufacturing Company in the amount of \$7,505.33, and subsequently recovered amounts aggregating \$1,750.00, a net advance of \$5,755.33. That company became insolvent in 1943 and the debt was charged off the books, as a bad debt. No recovery was made on said account, except as stated.”

Action by Commissioner:

As a result of the negotiations referred to in paragraph X, above, the Commissioner conceded plaintiff's contention that the account of Manganese Mining and Manufacturing Co. was allowable as a bad debt deduction for the year 1943 in the amount of \$5,755.33. Plaintiff's excess profits net income for the year 1943, as shown by the notice of deficiency, was accordingly decreased by that amount.

(c) Unallowable expenses (per notice of deficiency) \$12,284.81.

Allegations in Tax Court Petition:

“(c) The respondent erred in his determination that there were unallowable expenses claimed by petitioner in its returns as follows:

Taxable year ended December 31, 1943, \$12,284.81, \* \* \* and in failing and refusing to find that

such unallowable expenses were not in excess of the following amounts:

Year ended December 31, 1943, \$5,186.97.

\* \* \* \* \*

“(c-1) No detail is given, in respondent’s notice of deficiency of the items considered by him to be in the nature of unallowable expenses, except for the explanation ‘personal and farm expenses of W. A. Rushlight are not deductible’ and similar language. The only information which taxpayer has as to the possible nature of such items was obtained in informal conferences with a representative of the Treasury Department, from whom the following general segregation was secured:

	1943	*** **
Personal items of W. A. Rushlight .....	\$ 1,478.12	
Personal items of Mrs. W. A. Rushlight....	119.72	
Ocean Park farm expense.....	3,370.02	
Fixed assets charged to expense.....	1,816.95	
Payment to Earl Wilkinson.....	5,500.00	
***	<hr/>	
Total.....	\$12,284.81	

“(c-2) Petitioner is unable to identify the items alleged to be ‘personal items of W. A. and Mrs. W. A. Rushlight’ and petitioner believes and therefore alleges that the majority of said items to be club dues and expenses incurred for the sole benefit of the business and properly allowable as deductions.

\* \* \* \* \*

“(c-8) Earl Wilkinson, a Portland, Oregon, banker, rendered valuable services to petitioner in connection with financing, formation of joint ventures and advice as to contract procedure, giving freely of his own time and efforts. The charge for

his services was reasonable and constitutes an ordinary and necessary expense of conducting the business of petitioner for the year 1943.”

Action by Commissioner:

As a result of the negotiations referred to in paragraph X, above, the Commissioner conceded the plaintiff's contentions to the following extent: (1) That the “Earl Wilkinson” item of \$5,500.00 represented an allowable deduction as fees and commissions paid to the extent and in the amount of \$4,500.00, and (2) that of the four remaining items mentioned above, the sum of \$1,210.37 represented an allowable deduction as and for expenses incurred by plaintiff's president, W. A. Rushlight, in the conduct of its business. Plaintiff's excess profits net income for the year 1943, as shown by the notice of deficiency, was accordingly decreased by the amount of \$5,710.37.

Year 1945

(Affects 1943 tax in view of loss carry back provisions)

(d) Unrecorded sales (per notice of deficiency) \$23,573.47.

Allegations of Tax Court Petition:

“(b) The respondent erred in his determination that there were the following unrecorded sales not reported on petitioner's returns:

\* \* \* \* \*

Taxable year ended December 31, 1945, \$23,573.47, and in failing and refusing to find that sales of petitioner which were not recorded on the books



in error amounted to \* \* \* \$16,593.30 for the year 1945.

“(b-1) Examination of respondent’s notice of deficiency fails to disclose details as to the alleged sales not reported by petitioner for the years ended December 31, \* \* \* 1945, except the statement that such sales were to W. A. Rushlight, and to Rushlight Steel. The only information which petitioner has as to the nature of these items was furnished to it in informal conferences held with a representative of the Treasury Department as follows:

	Cost	Profit Added	Sales
Sales to W. A. Rushlight:			
* * *	\$ * * *		* * *
Year 1945 .....	366.09	164.74	530.83
Sales to Rushlight Steel:			
* * *	* * *	* * *	* * *
Year 1945 .....	16,227.21	6,815.43	23,042.64

“(b-2) The item entitled ‘Sales to Rushlight Steel’ apparently represents items determined by the respondent to represent work performed by the petitioner for Rushlight Steel Works, a division of the partnership of W. A. Rushlight Company, which were not charged to that company. The petitioner is unable to identify all of these items but is informed, believes, and therefore alleges that any such omissions were due to bookkeeping errors.

“(b-3) Respondent, in making his determination as to sales not reported, arbitrarily added to costs of items considered as sales not billed an allowance for profit. Since the work done for the said Rushlight Steel Co. which should have been billed was in the nature of an accommodation, the re-

spondent's determination in this regard was unwarranted and without foundation in fact."

Action by Commissioner:

As a result of the negotiations referred to in paragraph X above, the Commissioner conceded the plaintiff's contention that the item of "Unrecorded sales", as shown in the notice of deficiency, should be reduced by the sum of \$6,980.17, and that plaintiff's operating loss for the year 1945 should, therefore, be increased by that amount, with the result that its excess profits net income for the year 1943 was reduced by the same amount, i.e., \$6,980.17.

(e) Unallowable expenses (per deficiency notice) \$7,729.46.

Allegations of Tax Court Petition:

"(c) The respondent erred in his determination that there were unallowable expenses claimed by petitioner in its returns as follows:

\* \* \* \* \*

Taxable year ended December 31, 1945, \$7,729.46.

"(c-1) No detail is given, in respondent's notice of deficiency of the items considered by him to be in the nature of unallowable expenses, except for the explanation 'personal and farm expenses of W. A. Rushlight are not deductible' and similar language. The only information which taxpayer has as to the possible nature of such items was obtained in informal conferences with a representative of the Treasury Department, from whom the following general segregation was secured:

	* * *	* * *	1945
Personal items of W. A. Rushlight.....			\$ 293.52
Personal items of Mrs. W. A. Rushlight.....			21.18
Ocean Park farm expense.....			849.52
* * *			
Legal expense—C. C. Hall .....			5,000.00
Rushlight Steel Co. expenses.....			165.24
Philippine Construction and Development Company			500.00
* * *			

“(c-2) Petitioner is unable to identify the items alleged to be ‘personal items of W. A. and Mrs. W. A. Rushlight’ and petitioner believes and therefore alleges that the majority of said items to be club dues and expenses incurred for the sole benefit of the business and properly allowable as deductions.

\* \* \* \* \*

“(c-10) The legal fees to C. C. Hall represent a retainer fee of \$500.00 per month for ten months of the year 1945, as arranged with him. He was and is the petitioner’s legal counsel and has rendered valuable services to petitioner. The amount due, as agreed, was accrued on the books and deducted as an expense in the year 1945, was due within that year, and such amount as has not yet been paid is a bona fide debt of petitioner. Petitioner’s books are maintained on the accrual basis of accounting, and on the completed contract method, and, under that method of accounting, the services constituted a bona fide charge against completed contracts of the year.

“(c-11) The amount paid entitled ‘Philippine Construction and Development Company’ was paid, along with others to see what might be developed in the way of business in the Philippine Islands. No benefit was received from the expenditure, but the

amount is an ordinary and necessary expense of business development.”

Action by Commissioner:

As a result of the negotiations referred to in paragraph X, above, the Commissioner conceded plaintiff's contentions to the extent (1) that the “Philippine Construction and Development Company” item of \$500.00 represented an allowable deduction as and for business expense incurred in investigating the Philippine venture; (2) that the “Legal expense—C. C. Hall” item of \$5,000.00 represented an allowable deduction as and for legal expenses incurred by plaintiff in connection with its business, and (3) that of the four remaining items, mentioned above, the sum of \$396.38 represented an allowable deduction on account of business expenses incurred by plaintiff's president, W. A. Rushlight. The result of these concessions and adjustments was to increase plaintiff's operating loss for the year 1945 by the total amount of \$5,896.38, and to reduce its excess profits net income for the year 1943 by the same amount, i.e., \$5,896.38.

(f) Contract income understated (per deficiency notice) \$10,754.90.

Allegations of Tax Court Petition:

“(h) Respondent erred in his determination that contract income for the year ended December 31, 1945 was understated by \$10,754.90.

\* \* \* \* \*

“(g-1) No details are given in respondent's notice of deficiency as to the amount of \$10,754.90, alleged to be income from contracts completed, not

included in income. Reference is therefore made to information orally furnished petitioner by a representative of the Treasury Department at an informal conference for the following summary:

Logging contract on Juanita Investment Company property .....	\$ 4,871.83
Underpricing of contracts to W. A. Rushlight Company .....	5,883.07
	<hr/>
	\$ 10,754.90

“(g-2) Petitioner engaged in logging timber from property owned by Juanita Investment Company on the basis that its compensation would come from sale of timber cut therefrom. The loss sustained was \$4,871.83, the venture being abandoned in 1945 due to operating difficulties. No recovery was made from timber cut and left lying on said lands.

“(g-3) Petitioner engaged in a number of contracts during the year 1945 with W. A. Rushlight Company. Such contracts all resulted in losses and in settlement thereof, the W. A. Rushlight Company turned over to petitioner all of the contract prices which it received in payment for the said work. Respondent erred in arbitrarily determining that petitioner should have realized a profit at the expense of the W. A. Rushlight Company.”

#### Action by Commissioner:

As a result of the negotiations referred to in paragraph X, above, the Commissioner conceded the plaintiff's contentions (1) that the “Logging contract on Juanita Investment Company property” item of \$4,871.83 represented an allowable deduction as and for a loss sustained in connection with said logging contract, and (2) that the “Under-



pricing of contracts to W. A. Rushlight Company" item of \$5,883.07 did not represent income and/or profit derived or received by plaintiff. The result of these concessions and adjustments was to increase plaintiff's operating loss for the year 1945 by the total amount of \$10,754.90, and to reduce its excess profits income for the year 1943, as shown by the notice of deficiency, by the same amount, i.e., \$10,754.90.

(g) Bonus, Joe Sax (per notice of deficiency) \$10,744.57.

Allegations of Tax Court Petition:

"(i) Respondent erred in his determination that an alleged bonus to Joe Sax in the sum of \$10,744.57 should be eliminated in the year 1945 as 'not deductible as no bonus payable for 1945' and in failing and refusing to find that no adjustment of bonus to Joe Sax was necessary as no bonus had been either claimed or accrued on the books for that year.

\* \* \* \* \*

"(h) Joe Sax, an employee of petitioner engaged in technical duties relating to engineering, cost estimates, etc., received, in addition to other compensation, a bonus of 10% of the net profits of petitioner. For the year 1945, petitioner realized a substantial loss, and Joe Sax was not entitled in that year to a bonus, nor was he financially responsible, in accordance with his agreement with the company, for any of the loss sustained. Petitioner cannot understand the determination of respondent, who erred in reducing the loss of taxpayer by \$10,744.57 with

the explanation 'bonus accrual not deductible as no bonus payable for 1945' as there was no bonus accrued, paid, or otherwise entered on the books or claimed as a deduction for that year."

Action by Commissioner:

As a result of the negotiations referred to in paragraph X, above, the Commissioner conceded the plaintiff's contention that he, the Commissioner, had erred in respect of the "Bonus, Joe Sax" item of \$10,744.57, with the result that plaintiff's operating loss for the year 1945, as shown by the notice of deficiency, was understated by that amount, and that its excess profits net income for the year 1943, as shown by the notice of deficiency, was overstated by the same amount, i.e., \$10,744.57.

(h) In addition to the adjustments hereinabove referred to in this paragraph, which operated in favor of the plaintiff, and as a further result of the negotiations referred to in paragraph X, above, the plaintiff conceded, in favor of the Commissioner, (1) that the deduction for depreciation for the year 1945, as reflected in the notice of deficiency, was overstated by the amount of \$1,002.91, and (2) that its closing inventory for that taxable year, as so reflected in said notice of deficiency, was understated by the amount of \$12,332.76. The result of these concessions and adjustments was to decrease plaintiff's operating loss for the year 1945 by the total amount of \$13,335.67, and to increase its excess profits net income for the year 1943, as shown by the notice of deficiency, by the same amount, i.e., \$13,335.67.

(i) As a result of the adjustments described in subparagraphs (a) to (h), inclusive, of this finding, there was an overassessment and overpayment of excess profits tax of \$65,905.29 for the year 1943.

## XII.

(a) On line 38 of its income and declared value excess profits tax return for the year 1945, plaintiff reported an adjusted net loss of \$107,445.66. In computing the said loss of that amount, the plaintiff reported as income the sum of \$42,789.78 as representing the total amount of profit derived by it during that year from two contracts performed by it for Oregon shipyards. In the notice of deficiency, the Commissioner determined that of the income of \$42,789.78, so reported by plaintiff for the year 1945, the sum of \$41,104.38 should have been reported as income derived by it from said contracts during the year 1944. In its Tax Court petition, as aforesaid, plaintiff assigned error in respect of the Commissioner's determination, as set forth in **this** subparagraph, in words and figures as follows:

“(f) Respondent erred in his determination that gain on completed contracts of petitioner should be reallocated as to taxable years as follows:

Year ended December 31, 1944, increase in income \$41,104.58.

Year ended December 31, 1945, decrease in income \$41,104.58.”

In arriving at the deficiencies in income tax and excess profits taxes for the year 1944 in the respective amounts of \$3,972.41 and \$59,264.07, as shown by the stipulation of the parties and the decision

of the Tax Court entered pursuant thereto, as set forth in paragraph IX of these findings, no adjustment or change was made with respect to the Commissioner's determination as to the treatment of the profit derived by plaintiff from the two Oregon shipyards contracts referred to in this subparagraph.

(b) In arriving (1) at the deficiency in income tax for the year 1943 in the amount of \$1,647.44, as shown in the stipulation of the parties and the decision of the Tax Court entered pursuant thereto, as set forth in paragraph IX above, and (2) at the overassessment and overpayment of excess profits tax for that taxable year of \$65,905.29, the Commissioner determined and allowed as a deduction for that taxable year a net operating loss carry-back from the year 1945 in the amount of \$108,805.33. In the computation of said net operating loss carry-back of \$108,805.33, no adjustment or change was made with respect to the Commissioner's determination as to the treatment of the profit derived by plaintiff from the two Oregon shipyards contracts referred to in subparagraph (a) of this finding.

### XIII.

(a) If, in addition to the various income and expense adjustments and/or other changes referred to in paragraphs X and XI, above, the Oregon Shipyards contracts item of \$41,104.38 had, as a result of the negotiations referred to in those paragraphs, been treated as income includible in plaintiff's taxable income for the year 1945, instead of the year 1944, as aforesaid, then and in that event the excess



profits tax liability of plaintiff for the taxable year 1943, computed on that basis, would have been \$64,879.99; and the overpayment for that year would have been \$31,902.88 instead of \$65,905.29, as aforesaid.

(b) Of the deficiency in excess profits tax for the taxable year 1944 in the amount of \$59,264.07, referred to in paragraph IX above, the sum of \$35,144.25 is attributable to the \$41,104.38 Oregon Shipyards contracts item adjustment referred to in paragraph XII of these findings.

#### XIV.

Plaintiff's Tax Court petition, filed, as stated in paragraph VII, above, on August 23, 1948, together with the file in said case, was, by the Commissioner of Internal Revenue, transmitted to the Portland, Oregon, office of the then Technical Staff of the Treasury Department of the United States on September 9, 1948. At the same time, the Commissioner transmitted to said Technical Staff certain petitions and files in regard to the following related docketed and nondocketed cases for the taxpayers and years shown:

Docketed Tax Court Cases	Years
Juanita Investment Company vs. Commissioner of Internal Revenue, Docket No. 20020.....	1942, 1944
Juanita R. Leggett vs. Commissioner of Internal Revenue, Docket No. 20021 .....	1943
W. A. Rushlight and Betty Rushlight vs. Commissioner of Internal Revenue, Docket No. 20022.....	1944
W. A. Rushlight vs. Commissioner of Internal Revenue, Docket No. 20023 .....	1943
Nondocketed Cases	
Raymond Rushlight .....	1943
Betty Rushlight .....	1943



In connection with all of said cases, including plaintiff's case, the taxpayers at all times between September 12, 1947 and August 24, 1951, were represented by Eric Van, a certified public accountant, and at all times between September 12, 1947 and December 2, 1950, by Carl E. Davidson, a lawyer, both of whom were admitted to practice before the Treasury Department. Meetings were held between said two representatives of plaintiff and representatives of the Technical Staff, Treasury Department, Portland, Oregon, sometimes both representatives of plaintiff being present and sometimes one only, on the following dates: November 4, 1948; January 14, 1949; May 24, 1949; August 22, 1949, and October 3, 1949; and thereafter, almost daily until about December 5, 1949. Thereafter, similar conferences were held as follows: In the year 1950, on February 10, April 3, May 9, July 5, September 7, September 30, October 13, December 1 and December 12; in the year 1951, on March 10, April 19, April 27, May 10 and June 22. Between June 22, 1951 and April 16, 1952, discussions continued between members of the Technical Staff and one of the officers of plaintiff as to items of gross income and deduction affecting all of the above cases. Commencing in June, 1953, a series of similar conferences were held with the substituted counsel for plaintiff and said other taxpayers. These conferences culminated, on or about July 21, 1953, in the settlement of all of the cases mentioned above, including plaintiff's case, which said settlement included the resulting overpayment for the year 1943,

in the sum of \$65,905.29, referred to hereinabove.

In addition to the above conferences, there were a number of conferences held in November of 1950, and, by December 1, 1950, it appeared that the cases would be settled. In the Spring of 1951, tax computations were made by the Commissioner based upon the tentative adjustments reached in said negotiations which computations showed an over-assessment and overpayment of plaintiff's excess profits taxes for 1943. When the plaintiff's case was finally settled in July of 1953, the only changes in adjustments from the December 1, 1950, adjustments were as follows:

(1) Plaintiff was allowed a bad debt deduction of \$5,755.33 [Finding XI (b)];

(2) Plaintiff was allowed the \$4,871.83 loss on the logging contract [Finding XII (f)];

(3) The matter of delinquency penalties was settled.

During all of said negotiations, the representatives of the Commissioner had before them plaintiff's tax court petition. In 1953, after all of the items of expense and income had been agreed upon, it was discovered for the first time that no refund claim on Treasury Department Form 843 had been filed by plaintiff. In said negotiations, the matter of whether or not a refund claim had been filed by plaintiff was not discussed prior to 1953.

## XV.

Of the above sum of \$65,905.29, overpayment by

plaintiff, there was refunded to plaintiff the amount of \$35,044.35, this refund being made on November 8, 1953, by R. C. Granquist, District Director of Internal Revenue, said amount being the total of the payments made by plaintiff by way of credit on account of its 1943 excess profits tax assessment in the sums of \$32,401.25 on April 9, 1952, \$4,275.99 on April 23, 1952, and \$593.19 on November 19, 1952, less the sum of \$2,226.08. That said sum of \$2,226.08 represents interest from March 15, 1944 to March 15, 1946, on the sum of \$18,550.66, which was the amount of deficiency in plaintiff's 1943 excess profits tax prior to the application thereto of the carry-back loss from the year 1945.

#### XVI.

The Commissioner of Internal Revenue and the District Director of Internal Revenue have failed and refused to refund to plaintiff the balance of said overpayments, namely, the sum of \$30,860.94.

#### XVII.

On January 5, 1954, plaintiff filed with the District Director of Internal Revenue for the District of Oregon for transmission to the Commissioner of Internal Revenue an amended claim for refund on Treasury Department Form 843 in the sum of \$66,832.82 "or such other amount as is legally refundable". Said claim for refund referred to and incorporated by reference plaintiff's tax court petition and claimed that plaintiff was entitled to the refund of the overpayment and overassessment in plaintiff's 1943 excess profits taxes for the reasons

and upon the grounds set forth in plaintiff's tax court petition and as agreed upon by the plaintiff and the Commissioner. Thereafter and on June 1, 1954, the Commissioner, in the manner provided by law, notified plaintiff that said claim was disallowed. This action was commenced within two years of the date of said notice of disallowance.

### XVIII.

On November 12, 1953, the deficiencies in income tax, excess profits tax and penalties for the years 1943 and 1944, as shown by the stipulation of the parties referred to in Finding IX above, and by the decision of the Tax Court referred to in Finding IX above, were assessed against plaintiff by the Commissioner in accordance with the provisions of §272 (b) of the Internal Revenue Code of 1939.

Based on the foregoing Findings of Fact, the court makes the following

#### Conclusions of Law

##### I.

The Court has jurisdiction of the parties and of the subject matter by virtue of Section 1346 (a)(1), Title 28, United States Code.

##### II.

The time within which plaintiff could file a refund claim was extended to December 31, 1949.

##### III.

Plaintiff's tax court petition filed on August 23, 1948, and served upon the Commissioner constituted



a sufficient and timely claim for the refund of the overassessment and overpayment in plaintiff's excess profits taxes for the year 1943 within the meaning of §§ 322 (b)(1), 3772 (a)(1) and (2), and 3771 (e) of the Internal Revenue Code of 1939.

#### IV.

In investigating and acting upon the matters set forth in plaintiff's tax court petition, the Commissioner waived any requirement in the Regulations of the Treasury Department that the claim be submitted on a particular form.

#### V.

Plaintiff had the right to amend the claim for refund contained in its tax court petition after the statute of limitations had run for the filing of refund claims, and this action was timely commenced after the disallowance of said refund claim, as amended.

#### VI.

The plaintiff is entitled to judgment against the defendant in the sum of \$30,860.94 together with interest thereon at the rate of 6% per annum from August 23, 1948. Plaintiff is also entitled to judgment against the defendant for interest at the rate of 6% per annum on the amounts which were refunded to plaintiff (by way of credit) from the date said amounts were paid by plaintiff to the Director and/or Collector of Internal Revenue to November 12, 1953, the date that said credits were allowed.



Dated: December 21, 1956.

/s/ CHASE A. CLARK,  
Judge

Acknowledgment of Service attached.

[Endorsed]: Filed December 26, 1956.

---

In the United States District Court for the  
District of Oregon  
Civil No. 7582

A. G. RUSHLIGHT & CO., an Oregon corpora-  
tion, Plaintiff,  
vs.

UNITED STATES OF AMERICA,  
Defendant.

### JUDGMENT

The above entitled action came on for trial before the court without a jury, the plaintiff appearing by Denton G. Burdick, Jr., one of its attorneys, and the defendant appearing by Allen Bowden, attorney, Department of Justice, and Edward J. Georgeff, Assistant United States Attorney for the District of Oregon. The court, having considered the pre-trial order and the agreed facts therein, the testimony and exhibits introduced at the trial, and the briefs of counsel, and having filed its memorandum opinion, its findings of fact and conclusions of law, and

The court being fully advised in the premises,  
Now, Therefore, It Is Hereby Ordered and Adjudged that plaintiff have and recover judgment

against the defendant in the sum of \$30,860.94, together with interest thereon at the rate of six (6) per cent per annum from August 23, 1948; for the further sum of \$3,528.26, together with plaintiff's costs herein taxed at \$15.00.

Dated: December 21, 1956.

/s/ CHASE A. CLARK,

Judge

Acknowledgment of Service attached.

[Endorsed]: Filed December 26, 1956.

---

[Title of District Court and Cause.]

### NOTICE OF APPEAL

To: A. G. Rushlight & Co., an Oregon corporation, Plaintiff, and Denton G. Burdick, Jr., attorney for Plaintiff:

Notice is hereby given that the United States of America, defendant above-named, hereby appeals to the United States Court of Appeals for the Ninth Circuit from the judgment entered in this action on December 21, 1956, in favor of plaintiff and against defendant.

Dated this 18th day of January, 1957, at Portland, Oregon.

C. E. LUCKEY,

United States Attorney for the District of Oregon

/s/ EDWARD J. GEORGEFF,

Assistant United States Attorney

[Endorsed]: Filed January 18, 1957.

[Title of District Court and Cause.]

## CERTIFICATE OF CLERK

United States of America,  
District of Oregon—ss.

I, R. DeMott, Clerk of the United States District Court for the District of Oregon, do hereby certify that the foregoing documents consisting of Complaint; Answer; Pre-trial order; Opinion; Notice of appeal; Order extending time to docket appeal; Findings of fact and conclusions of law; Judgment; Notice of appeal; Designation of contents of record on appeal and Transcript of docket entries, constitute the record on appeal from a judgment of said court in a cause therein numbered Civil 7582, in which The United States of America is the appellant and defendant and A. G. Rushlight & Co., an Oregon corporation is the appellee and plaintiff; that the said record has been prepared by me in accordance with the designation of contents of record on appeal filed by the appellant, and in accordance with the rules of this court.

In Testimony Whereof I have hereunto set my hand and affixed the seal of said court in Portland, in said District, this 21st day of January, 1957.

[Seal]

R. DE MOTT,

Clerk

/s/ By THORA LUND,

Deputy

[Title of District Court and Cause.]

TRANSCRIPT OF PROCEEDINGS

This matter came on for hearing before the Honorable Chase A. Clark, sitting without a jury, at Portland, Oregon, on February 8, 1956, at 10 o'clock a.m. [1\*]

\* \* \* \* \*

A. N. WILLIAMS

called as a witness by the Defendant, after being first duly sworn, testifies as follows:

Direct Examination

\* \* \* \* \*

Q. (By Mr. Bowden): Mr. Williams, what was your occupation in the years 1948 to 1953?

A. I was employed in an organization that was then known as the [6] Bureau of Internal Revenue, and I was in charge of the Portland office of the then technical staff, which is now known as the appellate division.

Q. Mr. Williams, will you briefly describe to the Court the functions of your office at that time?

A. At that time the functions of our office were very much as they are today, some difference in details, but not many. We considered two types of cases, Income tax, State tax and Gift tax cases.

One type consisted of the cases in which statutory notices of deficiency had not been issued and the

---

\* Page numbers appearing at foot of page of original Reporter's Transcript of Record.

(Testimony of A. N. Williams.)

cases therefore had not been appealed to the Tax Court of the United States. The second type was the cases in which statutory notices had been issued and in which petitions had been appealed to the Tax Court and which were before us in an effort to effect a settlement of the case without actual trial before the Court.

Q. So it is your testimony that there were basically two; types of cases?

A. Yes, sir.

Q. One, pre-deficiency notice cases and two, post-deficiency notice cases,—cases that had been docketed in the tax court?

A. That is correct.

Q. I wonder if you would very briefly give a sequence of events that would occur prior to the issuance of a so-called 90 day letter? [7]

A. Of course, all such conferences originated in the office of the Internal Revenue Agent in charge. Now, after an examination had been made and the examiner had made a report comprehending his findings of fact and conclusions with respect to the case, it was reviewed in that office and if it was approved,—if his findings, his report was approved, the taxpayer was given an opportunity for conferences in that office. In many cases numerous conferences were necessary before the case was disposed of. In any event, if the taxpayer and the conferee agreed that was, ordinarily, the end of the case. If they did not agree the taxpayer was given an opportunity to have his case referred to



(Testimony of A. N. Williams.)

the technical staff, the organization with which I was associated. If it was so referred we held conferences and attempted to reach a settlement or agreement with the taxpayer and if we did not reach such an agreement we returned the case to the office of the agent in charge in order that a statutory notice might be issued on the basis of our findings. However, if the taxpayer, while the case was under consideration in this pre-statutory notice status did not ask for the case to be referred to us, then the Agent in charge issued a statutory notice on the basis of his own findings without any reference to the technical staff.

Q. Mr. Williams, would you briefly describe the conditions of a 90 day letter? [8]

A. I am sorry, I didn't hear that.

Q. Will you briefly describe a 90 day letter, in other words, will you briefly describe the purpose of a 90 day letter?

A. A 90 day letter is more properly referred to as a statutory notice of deficiency. A statutory notice of deficiency itself is ordinarily a one page document in which the taxpayer is advised that there has been a determination that there is a deficiency due in the amount of so many dollars. Attached to that document, however, is a statement of the basis upon which this determination is made. Ordinarily it would start,—practically in all cases, at any rate, it would start with the income shown by the return, showing the adjustments of that income, explain the adjustments and end with the in-

(Testimony of A. N. Williams.)

come as determined by the writer of the letter, or by the auditor who actually prepared the statement. In cases which involve State tax or gift tax or similar schedules, they would be attached. In cases that involved excess profit tax there would be other schedules showing computations of invested capital, credits computed on the basis of invested capital meeting the effect of the law involved. Then, after those adjustments of income and invested capital and the credits have been made there would be other schedules showing the computation of tax liability, ending with the deficiency shown by the face of the return.

Q. After the issuance of the statutory notice of deficiency [9] what right of appeal did the taxpayer have?

A. He had the right to petition the Tax Court of the United States.

Q. How long did he have?

A. Ninety days.

Q. After a case had been docketed in the tax court would your office have occasion to reconsider that case?

A. Yes. When a case was docketed with the Tax Court or a petition filed with the Tax Court, a copy of that would be in Washington. A copy of that petition would be referred to the National office of the Chief Counsel whose office is in Washington. I don't know particularly what happened at that time, I suppose it was largely for record purposes. At any rate, a copy of the petition was forwarded

(Testimony of A. N. Williams.)

to our office addressed to my superior for record making purposes. It was held there until it became associated with the administrative file, and the administrative file would be forwarded to us. I am speaking of 1948 now,—forwarded to us by the office of Internal Revenue Agent in charge whose office was in Seattle. When the administrative file was received a record was made of both the administrative file and the petition which we call the legal file, from Washington, and the two of them were brought together by the proper official or person in our office, the record clerk. Then they were transmitted directly to the office,—to the Portland [10] representative of the Chief Counsel, or the Counsel in charge of the Portland office for the purpose of answering the petition. After the petition had been answered and pleadings were complete, the administrative file was then returned to us, when I say us, I mean to me for assignment to someone under my direction who would consider the case from the standpoint of attempting to arrive at a mutually satisfactory basis of settlement with the taxpayer. At that point, after the case was assigned to this person the taxpayer would be contacted, conferences arranged and they would go on from there.

Q. Would the matter have been referred to you if you had considered the case prior to the issuance of the 90 day or the statutory notice of disallowance,—after the notice of deficiency was given?

A. Would you repeat that question?

(Testimony of A. N. Williams.)

Q. If your office had occasion to consider a particular case prior to the issuance of the statutory notice of deficiency would that case then have been referred to you after the petition was filed with the Tax Court?

A. Not automatically.

Q. Will you briefly explain the circumstances under which it would have been referred to you?

A. If the taxpayer requested us to consider it it would then be referred to us and we would again consider the case.

Q. At this stage of the case, in other words, one that was [11] referred to you after the filing of the petition in the Tax Court what was your principal function in considering that case?

A. Our function was to—our ultimate function was to reach an agreement, if possible, with the taxpayer with respect to all disputed points. Preliminary to that it was necessary for us to examine the files as they pertained to the income adjustments and all other adjustments and test those adjustments,—that is the adjustments of the taxpayer or petitioner against the records that we had or the record as supplemented by additional records of evidence that might be submitted. In other words, to determine what income adjustments were to be made if any on the basis of the petition as filed.

Q. Did there come a time during the course of your duties between the years 1948 and 1953 that you had occasion to consider a case in Tax Court entitled *A. G. Rushlight Co. vs. Commissioner*?



(Testimony of A. N. Williams.)

A. Yes, sir.

Q. Will you relate to the Court briefly the circumstances under which that case was referred to you?

A. In accordance with the procedure which I have outlined relating to the handling of cases after the issuance of statutory notices, the administrative file on the case of A. G. Rushlight & Co. was received by our office [12] on September 9, 1948. Also in accordance with that procedure the legal file was received on September 14, 1948. The two files were associated in the manner that I have outlined and they were given to the counsel in charge, turned over to him in order that an answer might be prepared to the petition,—the taxpayer's petition.

Q. After the answer had been prepared and filed by legal counsel was the matter then referred back to your office?

A. Yes, automatically it came to us.

Q. Now, so as not to confuse the matter, what other cases in addition to this particular case was referred to you at the same time?

A. There were the individual cases of W. A. and Betty Rushlight,—I should say the individual case,—the case of W. A. and Betty Rushlight, joint returns having been filed for certain years,—the individual case of W. A. Rushlight who, for the particular year involved, filed a separate return. The case of the Juanita Investment Company, and the case of Juanita Leggett, those constituted the



(Testimony of A. N. Williams.)

five cases in which petitions had been filed with the Tax Court, all of which were referred to us at the same time. In addition to that there were certain related non-docketed cases.

Q. Would you say, Mr. Williams, that these cases were related [13] in the sense that certain income and expense items as to one would necessarily affect the others?

A. Yes, they were. That was particularly true of the three cases that I mentioned first, namely: A. G. Rushlight Co., W. A. and Betty Rushlight and W. A. Rushlight. It was true in a lesser degree with respect to the relationship of the two cases, W. A. and Betty Rushlight, W. A. Rushlight on one hand and the Juanita Investment Company on the other.

Q. Now, Mr. Williams, starting with the period of September 1948 when these cases were referred to your office for consideration, could you briefly trace the sequence of events which occurred during the period from 1948 to 1943?

A. 1943 you say.

Q. Pardon me, 1948 to 1953?           A. Yes.

Q. That does not have to be in detail Mr. Williams, at this point.

A. I already stated that the cases were referred to us after the pleadings were completed and our records show that they were received for the purpose of conducting settlement negotiations on October 14th, 1948. At that time I did something that I have since regretted to a certain extent, I assigned

(Testimony of A. N. Williams.)

the cases to myself for consideration. A conference was arranged for,—I can't give you the exact date [14] unless I take time to examine my file——

Q. ——The year?

A. I think it was in November.

Q. The year?

A. 1948, but that was only a very preliminary discussion. There was a further conference very early in 1949. There were, I believe, three conferences during the Spring and Summer of 1949. About, I should say not later than the first of September and probably before that, in 1949, we were advised that the Tax Court would be here in Portland beginning on October 24, 1949, and from that time and for a period of several weeks there were numerous discussions had with respect to what should be done in these cases. Mr. Pigg and I,—Mr. Pigg being the Counsel for the Government, and I conferred between ourselves, and with the Petitioner's attorney of record as to the handling of the cases at that time, with the result that no agreement with respect to any settlement was reached before the call of the Calendar and when the cases were called a motion was made on behalf of the Petitioner that the case be continued and that motion was not opposed by the Government. Thereafter, during the year 1950 another series of conferences were held which were not productive of any settlement resulting, and the case, later in the summer or early fall was again placed on the calendar of the Tax Court for hearing, trials of

(Testimony of A. N. Williams.)

which were scheduled to begin at Portland [15] October 23, 1950. For a period of several weeks before October 23, there were frequent discussions between myself and counsel for petitioners for the purpose of resolving as many of the issues as we could and considerable progress, as to a meeting of the minds, was made during those discussions, but a definite basis of settlement was not reached. When the case was called on the hearing date of the calendar it was again continued with the thought being that negotiations for settlement had progressed to such a point that it was reasonable to anticipate that settlement would be reached within a reasonable period of time. Immediately after the Tax Court had completed hearings in other cases I gave as much attention to the case as time permitted and there were a number of conferences held during the latter part of November and they culminated in a conference that was held on December 1, 1950, and at that time the negotiations had progressed to the point that it appeared that we were really in a settlement area. There were some undecided matters that it was necessary for me to give some additional thought to, but on December 1, 1950, it definitely appeared that we were within settlement area. After that conference and for the remainder of the year,—I didn't keep a time-sheet on this but I think I gave practically my entire time to the matter of this case, and that situation continued during those weeks, it [16] seemed that the prospects for settle-

(Testimony of A. N. Williams.)

ment were improved, if anything, over what they had been on December 1. Early in 1951 I was advised that the settlement proposal—I was advised that the suggestion, I could say that rather that proposal, the suggestion that had been made leading toward a settlement, in the conference of December 1, 1950 and prior thereto were not acceptable to Mr. Rushlight, and from that time on for a period of approximately three months very little was done on the case, and I believe it was in April 1951 that conferences were again resumed, and there was a series of three or four conferences, I can't tell exactly without looking at my record. Between that date, which was about the middle of April,—between that date and the latter part of June,—by the first of July it became apparent that the parties were not in an area of agreement and for a period of several months my work on the case was sporadic, and Mr. Robert Horning, who was employed by Mr. Rushlight in an accounting capacity worked with me however, at times during the Summer and Fall and I think until early in 1952 in preparing income statements, schedules of income on which we could agree. Primarily our intention was to have figures so that each one of us could know what the other was talking about in the event either or both of us should have occasion to give the cases further consideration at some later date. [17] That work was completed in the early part of 1952, and from that time there was nothing done on the cases until they were set down for trial



(Testimony of A. N. Williams.)

before the Tax Court for the third time for a hearing beginning in Portland, I believe that was in July 1953. Approximately one month before the 1953 hearings Mr. Girigley called me and said that he had been retained by Mr. Rushlight and asked if conferences could be arranged for the purpose of exploring the possibilities of settlement without trial, so as a result of that telephone call a series of conferences followed in which Mr. Girigley and Burdick participated and represented Mr. Rushlight and his company and Mr. Pigg of the chief counsel's office in Portland and Mr. Durkins of the chief counsel's office in Seattle, whose post of duties was in Seattle participated together with myself.

Q. What was the ultimate result of these conferences in the middle of 1953?

A. The ultimate result was that a basis of settlement was agreed upon, income adjustments were agreed upon and these adjustments were turned over to our auditor,—the auditing staff at our office. Computation of the taxes was made and those figures were agreed upon by representatives of the taxpayer.

Q. And the case was closed in your office?

A. Stipulations with respect to the tax liability with [18] respect to which the tax court had jurisdiction were prepared on the basis of those audit figures and were filed with the Tax Court I believe August 6, 1953, I believe that is the date it was.

Q. Now with respect to the item of excess profit



(Testimony of A. N. Williams.)

taxes for the year ending December 31, 1943, with which the Tax Court said that it had no jurisdiction, what steps were taken by you to settle that liability?

A. In computing the tax liability with respect to which the Tax Court did have jurisdiction it was found,—let me rephrase that,—in computing the tax liabilities with respect to the taxes which were actually at issue before the Court, computations were also made by our audit section showing the excess profit tax liability for the year 1943.

Q. As a result of form 870 executed—

A. Following up and giving effect to that computation, we prepared form 870 which is a form that the appellate division uses in cases that it considers as in the pre 90 day status as distinct from the docketed status which shows the over assessment or the deficiency as the case may be.

Mr. Bowden: Your Honor, we have attached seven exhibits to the pretrial Order, now, may I show Mr. Williams a copy of exhibit numbered 3 so that he may refresh his recollection.

The Court: I notice these exhibits, and a stipulation that they may be identified, I don't know [19] but I think maybe that these exhibits should all be offered and admitted.

Mr. Bowden: I would like to offer these exhibits, your Honor.

The Court: All of the exhibits shown in the pretrial order may be shown as offered and admitted.

(Testimony of A. N. Williams.)

Q. That particular document was prepared in your office, is that correct, Mr. Williams?

A. Yes, sir, that's correct.

Q. And that document was sent to the Counsel for the taxpayer?

A. Yes, it was, it was either sent to him by mail or handed to him in my office, I am not sure about that.

Q. Do you recall at the time that particular document was prepared and delivered to the taxpayer, or counsel for the taxpayer, what his reaction was to the section 322 limitation as shown in the upper right hand corner?

A. As I recall there was some but not great hesitancy with respect to signing the document,—the agreement form with that statement up there which reads “Accepted as to amount of overpayment refundable subject to provisions of Section 322, Internal Revenue Code”, signed A. N. Williams, Associate Chief Appellate Division. There was some hesitancy on the part of counsel for the taxpayer but no great hesitancy in signing the agreement form.

Q. Can you recall anything that was said on those occasions [20] Mr. Williams, either by you or by counsel for the taxpayer?

A. No, I can't recall anything in particular, there was some discussion but as I say, it could be summed up in what I just said,—they regretted naturally that we insisted that this qualification be added to the agreement form.

(Testimony of A. N. Williams.)

Q. Was there any discussion at that time regarding a claim, the filing of a claim for refund?

A. At the time of signing this,—I recall very distinctly the day that this agreement was signed. At that particular moment I do not recall that there was any discussion with respect to this claim for refund.

Q. Anything on or about that time which would bear on that?

A. When the matter was discovered, that this overassessment was apparently barred, a careful search was made of the file for a claim——

Q. ——of your files, Mr. Williams?

A. Yes.

Q. Go ahead.

A. And an examination was made of the statutory notice and it was brought to light at that time that the statutory notice which had been issued by the then Revenue Agent in charge in Seattle, Mr. Stockton, had a paragraph in it which cautioned the taxpayer with respect to the advisability of filing a claim for refund. [21]

Q. Did counsel for Taxpayer request you to search your files for claim for refund in this particular instance?

A. I don't believe that they made specific requests. We searched our files independently of any request that might have been made of us.

Q. Mr. Williams, with respect to the other docket cases which you had under consideration, after they were ultimately settled, income and ex-

(Testimony of A. N. Williams.)

penses determined did they have proper, or did it appear that in all of those cases proper claims for refund had been filed?

A. May I just answer it this way,—there were in this group of cases a number of claims for refund, I can't tell without examining our files how many, but there were a number, and I can recall no controversy or discussion with respect to any other missing claims. I don't think that there was any discussion.

Q. Now, may I go back a few moments,—During the course of your discussion of this case and other cases would you say particularly what your attention was directed to. In other words, was it directed to the income and expense solely or did it go further and relate to other items?

A. My attention was directed to the items of income, deductions, expenses, items of invested capital and there are other items that must be taken into consideration in figuring tax, in these particular years for this taxpayer at any rate. I am thinking of the credits for excess profit tax purposes [22] which followed automatically and were given consideration by our auditors, so, in answer to your question, we considered income, deductions, expense, invested capital items and in this particular case the question of whether the certain penalties had been properly or improperly imposed.

Q. Did you ever during the discussions refer to

(Testimony of A. N. Williams.)

amounts which may or may not have been refundable to the taxpayer?

A. Are you asking with respect to the period, we will say, prior to June 1953?

Q. Yes.

A. No, there was no discussion of the sums refundable.

Q. At any time did you ever refer these cases to the audit section for computation of any amounts which may have been refundable prior to 1953?

A. Not on the basis of agreed income determination. There were certain tentative computations made but they were not on the basis income adjustment which had been proposed and accepted as for settlement purposes or anything of that nature, in other words, I spoke a moment ago of the facts, or the result of the conference on December 1, 1950, and the preceding conferences where it appeared that we were within an agreement area. Now, sometime in the early part of 1951 computations of tax were made on that and a number of other basis but they were not on the basis of agreed income adjustments.

Q. At any time during the discussions prior to 1953 did the taxpayer or his representative ever discuss the matter of claims for refund in this case?

A. I am trying to review the steps in this period of about three and a half years, in fact, almost four years that these cases were before me and I can't recall that the matter of refunds, as such,



(Testimony of A. N. Williams.)

were ever discussed until immediately before the closing of the case in August 1953, immediately before the filing of the petition with the Tax Court in August 1953, when I say immediately, I mean a matter of a few weeks before that.

Q. I wonder if you would refer to exhibit numbered one. Page two of the statement, will you kindly read to the Court the first paragraph and then explain to the Court the reason for the insertion of that paragraph in that letter?

A. The paragraph reads as follows: "The over-assessment shown herein will be made the subject of a certificate of overassessment which will reach you in due course through the office of the collector of internal revenue for your district, and will be applied by that official in accordance with Section 322 (a) of the Internal Revenue Code, provided that you fully protect yourself against the running of the Statute of Limitations with respect to the apparent overassessment referred to in this letter, by filing with the collector of internal revenue for your district, a claim [24] for refund on Form 843, a copy of which is enclosed, the basis of which may be as set forth herein." Now, what was the rest of your question?

Q. What was the purpose of inserting that paragraph in that letter? Also the purpose of enclosing form 843 with that letter?

A. Of course, I didn't issue this letter but I think I can answer your question. Page one of this statement sets forth the tax liabilities, that

(Testimony of A. N. Williams.)

means the tax liabilities determined by the office of the Internal Revenue Agent, the amount previously assessed and the deficiencies and penalties asserted. It also, the same tabulation, shows an overassessment of excess profit tax for the year 1943 in the amount of \$12,853.92. Now, in issuing this statutory notice the man who prepared it was cognizant of the fact, apparently, that if a petition was filed with the Tax Court, the Tax Court would not have jurisdiction with respect to the overassessment of the \$12,853.92, therefore, for the purpose of putting the taxpayer on notice in order that he might or it might protect its interest, the paragraph that I have just read was inserted in the statutory notice and a copy of the form which was recommended to be used, was enclosed, form 843.

\* \* \* \* \* [25]

#### Cross Examination

Q. (By Mr. Burdick): Regarding the procedure that you have described Mr. Williams, as I understand it you were the head of technical staff here in Portland, isn't that right,—up until they changed it to the appellate division?

A. No, that isn't correct. At that time the appellate function of the then Bureau of Internal Revenue in this region, this section of the country was in the hands of the Northwestern Division Technical Staff, and we had two offices, one in Seattle and one in Portland. The territory embraced was Alaska, Washington and Oregon, Idaho and Montana. Cases arising outside of Oregon [26]

(Testimony of A. N. Williams.)

or Washington would normally come to either Seattle or Portland, depending on the location of the taxpayer or their pleasure. Now, as to the Seattle office, by immediate superior was in Seattle and was the head of the division and I was in charge, directly responsible to him, of the Portland office. I believe my title at that time was Technical Adviser in Charge, or something like that.

Q. Did that situation continue up through all of the period up through 1953 except for the change in name?

A. It did not. There was an extensive reorganization of the entire Revenue Service in 1952, and it became effective as to this section of the country on October 30, 1952, I believe, and at that time, not immediately, but shortly after that I was placed directly in charge of the Portland office and given authority to settle cases on my own responsibility. I was still responsible to Mr. Hilacker, in that he received a different title and there was another adviser in the Seattle office that was also responsible to him,—this adviser that I speak of and myself occupied the same respective positions in our cities.

Q. From October 30, 1952 when this reorganization went into effect you were given authority to settle cases under that procedure were you?

A. I was,—not immediately but very shortly, it was a matter of delegation and the delegation could not become effective for a period of some weeks or perhaps months, [27] but pursuant to the

(Testimony of A. N. Williams.)

general plan of the reorganization I was given that authority.

Q. Then, in other words, when Mr. Gerany and I settled this case with you in 1953 at that time you had been delegated authority to settle cases?

A. I had settlement authority at that time.

Q. And that authority stems from the Commissioner of Internal Revenue does it not?

A. That's right. It was a matter of delegation, two different steps I believe.

Q. Anyway, when you settled the cases it was because you were the representative, legally in charge of this office for the Commissioner of Internal Revenue?

A. To that extent, yes, that's right. Within the limits only of the functions of what became known as the appellate division.

Q. Prior to that time you had to submit settlement to your superior, Mr. Hilacker, didn't you?

A. That's right.

Q. But you are the person who negotiated with the taxpayer on behalf of the technical staff in this area prior to October of '52?

A. Yes, on behalf of the technical staff, but that should be qualified by stating that in as much as this was a docketed case, the technical staff or the appellate division counsel also participated in negotiations, at least to a limited [28] extent, I mean by that, they did not participate in all conferences by any manner or means, but they did participate



(Testimony of A. N. Williams.)

in some of them and Mr. Pigg was kept advised of our progress.

Q. Between you and the members of the counsel staff the primary responsibility was on you wasn't it? You did make the decisions of settlement after consulting with them?

A. Will you ask that question again?

Q. Yes, as between you and the attorney in the counsel's office that you consulted with, was that Mr. Pigg,—who had the primary responsibility as between the two of you? Who had that responsibility to decide as to whether the matter was settled?

A. As I understand your question there was no primary responsibility. It was my responsibility,—as a practical matter, the way it worked out in this case, it was my responsibility to negotiate with the taxpayer's representative and after a basis of settlement had been reached, had been proposed I will say,—and was determined to be acceptable to me, one that I would recommend to my superior, to my immediate superior, who was Mr. Hilacker, after the basis of settlement had been determined to be one that I would recommend as being acceptable to me then I conferred with Mr. Pigg to see if it was acceptable to him. In other words, we made joint recommendation, [29] our recommendations were joint as between Mr. Pigg and myself.

Q. Now, when this case was finally settled it meant that the settlement was agreeable to both you and Mr. Pigg?

A. That's right.



(Testimony of A. N. Williams.)

Q. Your office was the only office who had authority at that time to settle a docketed case, wasn't it Mr. Williams?

A. We did not have authority and ever had authority to settle a docketed case without concurrence of Mr. Pigg's office.

Q. Then, between your office and Mr. Pigg's office, there wasn't any other office that had anything to do with settling docketed cases?

A. No, there was not.

Q. On these discussions that you had that you described to the Court here extending over this period, did you keep Mr. Pigg's office advised of all those discussions from time to time, as to their progress?

Q. We made no attempt to advise Mr. Pigg or anyone in his office with respect to the day by day, and sometimes hour by hour development, we did not do that, but on the other hand when something came up, when it appeared that a step that was of real importance had been taken or a real gain had been made in our ultimate objective of reaching an agreement, either to agree or disagree, when a point such as that was reached I always conferred with [30] Mr. Pigg and advised him of the progress or lack of progress which had been made.

Q. Now, on these conferences that are listed in the pretrial Order, were you present Mr. Williams, at all of those that are listed in the pretrial Order?

A. Yes, there is not a conference listed in the

(Testimony of A. N. Williams.)

pretrial Order that I did not attend. I don't think there was ever a conference held in this case that I wasn't in on.

Q. Then you were present at all of the negotiations mentioned in the pretrial Order,—you were there at every conference?

A. Yes, I think so.

Q. You had various people with you at times but you were there yourself at each one of them?

A. That's correct.

Q. I think you said that you referred this case to yourself when it was referred to your office, I think the word you used was that you assigned it to yourself?      A. I did.

Q. Now, referring to your testimony in regard to this meeting that you mentioned on December 1, 1950, I think you said that at that time you felt that your negotiations were in what you termed as in a settlement area?      A. That's correct.

Q. At that time had you given consideration to all of the issues that are set forth in the pretrial Order,—Just a minute, I think I better rephrase that question. [31] You are familiar with the items of income and adjustments that are set forth in detail in paragraph 11 of the pretrial Order?

A. May I have a copy of the pretrial Order. You said paragraph 11.

Q. Paragraph 11, page 6, that paragraph ends on page 14.

A. Yes, I am familiar with those adjustments.

Q. Were those adjustments considered by you,

(Testimony of A. N. Williams.)

those mentioned there,—were they considered by you in connection with this area of settlement that you thought you reached in 1950, December 1, 1950?      A. Yes, they were.

Q. All right, now, I think you said that Mr. Gerany and I represented the Plaintiff here during the time, starting in 1953, isn't that right?

A. The first contact with me was, I think, in June, around June 22 or 23, 1953.

Q. Now, you are familiar with how this case was finally settled as is shown in the pretrial Order are you not. I mean, how it was finally settled as to all of these issues shown in that paragraph?

A. I don't attempt to carry them all in my mind, if that is what you mean.

Q. Can you tell what changes there are in the way these issues were finally settled as shown by the Pretrial Order and the way they were settled at the time you thought you [32] were in an area of agreement, December 1, 1950. What changes were made as a result of negotiations.

A. You have spoken of this agreement, the result of this conference of December 1, 1950 as settlement reached, that was not a settlement, there were certain adjustments that had been discussed previously in numerous conferences, certain income adjustments. As I recall what happened in the conference of December 1, 1950, the discussion pertained very largely to the matter of penalty, and it is to be remembered that the corporation case which we now have before us and the individual

(Testimony of A. N. Williams.)

cases which involve the partnership and had very complicated features, were all under consideration. Now, these income adjustments as to the corporation had been discussed in previous conferences at great length and there was very little discussion of those adjustments in the conference of December 1, 1950 as it pertained to the corporation income. There was a large amount of discussion as to penalties. Now then, in the final settlement that was reached referring to the corporation, there was a reduction income for the year 1943 in the amount of \$5,755.33 which at the time of the December 1, 1950 conference it had not been anticipated would be made, that is for 1943. In computing the net operating loss carry-back from the year 1945 to the year 1943 there was an additional deduction of income allowed of \$4,871.83. [33]

Q. That item you just mentioned Mr. Williams, \$4,871.83, that is the item shown in connection with the logging contract with the Juanita Investment Company, isn't that right?

A. That is correct.

Q. In other words, the only changes that were made in what you call the anticipated settlement, or possible settlement were these two items, otherwise it went through the way it was in 1950?

A. No, it did not. Because in the negotiations that were conducted up to December 1, 1950 and in that conference I had not reached a decision in my own mind as to whether or not delinquency penalties should be sustained in the case of the cor-



(Testimony of A. N. Williams.)

poration by reason of failure to file a timely excess profit tax return. I don't have the figures before me at the moment but I believe there was a conditional concession on final settlement on that, before I testify as to that I would like to examine it further.

Q. In other words, there were three things that were different you think, between the way it was finally settled and the figures in 1950, the two you mentioned and the matter of penalties, is that right?

A. I think that is correct as far as the corporation is concerned.

Q. As far as the corporation is concerned?

A. Yes, that is correct. [34]

Q. Then I think you said that you made some computations based on the December 1, 1950, figures as to what the taxes would be?

A. I never made any computations.

Q. Well, that someone made tentative computations on the amount of the taxes, that was my recollection of your testimony.

A. I am sorry, I didn't quite understand that last question.

Q. I may have misunderstood your testimony on direct examination but I thought you said something to the effect that the only time you figured how much tax was involved here in these adjustments of income and expense was based on these 1950 figures, and that you did make a computation at sometime or another?



(Testimony of A. N. Williams.)

A. I never made any.

Q. Did you have any made?

A. Our audit section made the computation.

Q. Did you see those computations?

A. I saw the result of them.

Q. You saw the result of them?

A. Yes, but I am not prepared to testify that those computations followed or did not follow exactly the income adjustments that I had in mind and I think that Mr. Rushlight's then representatives had in mind.

Q. Were those computations based generally on the 1950 figures? [35]

A. Generally they were, yes, but those were not made until—I should say that was only one group of computations that were made and none of those were made until well into the year 1951, the spring of the year 1951.

Q. And those computations if they are based on this 1950 area of agreement they would show a substantial overassessment of the 1943 excess profit tax wouldn't they?

A. Yes, they would show an overassessment in the 1943 excess profit tax.

Q. I think you testified in direct examination that you gave your entire time to this case during December 1950, when you say this case you meant these related cases, did you?

A. That is correct all these cases.

Q. I think you said that you treated all of these cases mentioned in the pretrial Order,—that you treated them all together?

(Testimony of A. N. Williams.)

A. When you say all the cases do you refer to the corporation and A. G. and Betty Rushlight—

Q. —You mean Raymond Rushlight don't you?

A. No, not for this purpose.

Q. Maybe we better start over again.

A. What was this question?

Q. Did you treat all these Rushlight cases that are mentioned in the pretrial Order together. Did you treat them all together?

A. It cannot be said that we treated the Juanita Investment [36] Company and Juanita Leggett as a part of this group. The issues involved in those cases were almost entirely distinct from the other cases.

Q. Except for those two cases they were treated together,—that is, the Juanita Investment Company and Juanita Leggett matters?

A. Yes, these conference dates mentioned in the pretrial Order, it would be impossible to say that a conference was held on such and such a date with respect to the corporation because the probabilities were that other cases were discussed at the same conference, or issues involved in the other cases.

Q. When did you first discover that no refund claim on form 843 had been filed by the Plaintiff in this case?

A. I have no record of the exact date but it was at the time we were working over the figures for

(Testimony of A. N. Williams.)

the purpose of determining what the stipulated deficiencies would be on the overassessment.

Q. That would be after Mr. Gerany and I were in the case would it?

A. Oh, yes, possibly a week before the stipulation was filed with the Tax Court.

Q. That was in 1953 was it?

A. That is correct.

Q. Was that after Mr. Gerany and I had agreed with you on [37] all the items of expense and income? A. That's right.

Q. So we had agreed on all items of income and expense before it was discovered that there wasn't any refund claim? A. That is correct.

Q. You had refund claims for Betty Rushlight and Raymond at that time, didn't you?

A. I have no recollection at present what refund claims we had and I can't tell from these records here, but I assume those were the ones we did have. We did have refund claims?

Q. You had a number of them, didn't you, in connection with these cases?

A. We did, yes.

Q. Now, these other cases,—just strike that,—Mr. Williams did you handle these cases just like you would have handled them if there had been refund claims filed by the plaintiff here?

A. That question involves so many possible differences of fact that I cannot answer it.

Q. Did you handle the cases any different up to the time that you discovered that there wasn't

(Testimony of A. N. Williams.)

any refund claim than you would have done if there had been?

A. Again I say I cannot answer that question because if a refund claim had been filed it is entirely possible that [38] an allegation of the facts would have been made in that claim and evidence would have been submitted or a separate examination by a revenue agent would have been made at the time which would have divulged information that would change the entire aspect of the case. I can't answer that.

Q. So you did have refund claims by Betty and Raymond Rushlight and by other taxpayers here, didn't you?      A. We did.

Q. Did you make any special investigation by reason of the fact that you had their refund claim before you?

A. I believe, as I recall now, that it would have been impossible for us to consider those refund claims to a conclusion without a supplemental investigation being made in the field by a revenue agent or someone delegated by the revenue agent in charge, such investigation being made after the cases were referred to us. I think; it would have been impossible, before I make a categorical statement to that effect I would have to look up the record to refresh my memory,—records that I do not have here.

Q. Now, Mr. Williams, in those negotiations that you had in 1951, '52 and '53, I think you testified

(Testimony of A. N. Williams.)

that you never referred to any amounts that were refundable in the form of tax, is that right?

A. That's right. [39]

Q. But if you followed through on the adjustments that you did discuss, the income and expense deductions,—if you followed through and computed it then if there was a deficiency or refund that would follow as a matter of course based on the tax levy?

A. In any event it would depend upon,—the overassessment or deficiency would depend on the state of facts relative to the statute of limitations.

Q. Then if you computed taxes based on these figures you are using it would show an overassessment, an overpayment or a deficiency then as a matter of course?

A. Yes, it would show additional tax due, overpayment due the taxpayer but of course, whether the additional tax was assessable and whether or not the overpayment was refundable would be determined on the facts so far as the statute was concerned.

Q. But you were not concerned with that?

A. No.

\* \* \* \* \*

Q. Mr. Williams, when you were handling these Rushlight cases, these negotiations that you mentioned here, when they were being carried on, did you assume that [40] the claim had been filed as suggested in the statutory notice, the section that you read to the Court here?



(Testimony of A. N. Williams.)

A. The question of whether a claim had been filed or not never arose in my mind because we were devoting ourselves to the determination of tax liability.

Q. Now, will you explain it again how you would have handled it differently if a claim had been filed on form 843 referring to the 90 day letter?

A. I don't see how I can answer that question for the simple reason that if a claim had been filed it is not improbable at all that the entire picture of the cases would have changed. What I mean by that is this, that the claim might have been investigated in the Agent's office before being referred to us. The claim might have never come to us and if it came to us whether it was investigated or not, and the question that it would in all probabilities have carried a separate statement of facts based upon the evidence contained in the claim or the development of consideration,—the development as a result of a consideration of the statements made in the claim it is probable that the cases would have assumed entirely different aspects.

Q. All right, assuming that a claim had been filed as was pointed out in the statutory notice, and I quote: "namely, the basis of which may be as set forth herein" would that claim have been investigated? [41]

A. If a claim had been filed it would have been filed in the agent's office or the Director's office. In the office of the Collector before the reorganization

(Testimony of A. N. Williams.)

of the Bureau and the office of the Director if after that time. What they would have done with that claim I don't know. I can speculate as to what they might have done with the claim.

Q. Now, in the case of the other taxpayers here who didn't have docketed cases, those claims were referred to you?

A. Yes, they were, they came to us with the file.

Q. Did you examine these other claims for refund during the course of your negotiations?

A. No, I don't think I did examine them.

Q. Then we can say that you didn't know what claims for refund were there and what claims were not, is that right?

A. Not until we determined tax liability.

Q. In other words, it wasn't until after Mr. Gerany and I on behalf of the plaintiff here and the other payers and you agreed on the items of the expense and income, it wasn't until after that that we even inquired as to the matter of the claim, is that right?

A. Ask that question again will you?

Q. It wasn't until after we came to a settlement with you as to items of income and expense that we went into the matter of whether claims had been filed or not, is that right?

A. In our conferences we didn't discuss the matter of [42] whether or not claims had been filed. The situation with respect to individuals was somewhat different in any event from the case of the corporation for these reasons,—these refunds that

(Testimony of A. N. Williams.)

were claimed in the case of the individuals were attributable to adjustments increasing tax liability in the case of Mr. Rushlight, namely as a result of the Bureau holding in the statutory notice of deficiency issued in his case that Mr. Rushlight and his brother Raymond should not be regarded as partners. Standing alone, that determination would increase the tax liability of Mr. Rushlight with corresponding overassessment in the case of Mrs. Rushlight and Raymond, that was apparent on the face of the matter and there was no particular reason to examine those claims, they were what we know as protective claims.

The Court: I know Mr. Witness, that you are endeavoring to answer these questions correctly, but I call your attention to the fact that you haven't as yet answered the attorney's question.

A. I don't remember that we talked about that specific question until after agreement had been reached with respect to items of income, deductions and tax liabilities determined. [43]

\* \* \* \* \*

### Redirect Examination

Q. (By Mr. Bowden): Thank you very much on that point Mr. Williams. Now, I think you stated a moment ago that the claim for refund, or a claim for refund would generally find its way to the Director's office, or the audit division?

A. It would normally be filed with the Director, yes.

Q. At all times during these negotiations prior

(Testimony of A. N. Williams.)

to 1942 you did not have authority to dispose of a case administratively?

A. Prior to 1953 would be more exact.

Q. Prior to 1953 you alone did not have the authority?

A. It would be more correct to say that at the time I received delegation,—the point I am making is that I can't say whether it was before January 1, 1953 or after January 1, '53.

Q. In other words, you could not commit the Government on any settlement, and any settlement you proposed was [48] reviewable and would have to be accepted or rejected by, not only your superior but also legal counsel's superior, Mr. Pigg?

A. That's right.

Q. After 1952 the situation was such that you and legal counsel had to concur on a recommendation?

A. That is correct.

Q. If you concurred you had authority to settle?

A. That's right.

Q. This latter authority I speak of was in existence at the time you settled the instant case?

A. The latter authority was in existence at that time, that is right.

Q. You and Mr. Pigg had authority to dispose of this case administratively?

A. Yes, subject, of course to the requirements of disposing of the petition through Tax Court channels.

Q. Yes, but in the last analysis you and Mr. Pigg had the authority?

A. Yes.

(Testimony of A. N. Williams.)

Q. At any time during the consideration of these cases in your office,—may I rephrase that question. One of the principal contentions in this case, Mr. Williams, is that the petition filed in the Tax Court constituted a claim for refund, at any time during the considerations of these cases in your office did you or your office consider [49] the petition filed in the Tax Court as a claim for refund?

A. No, we did not.

Q. Mr. Williams, does a review of your files indicate that prior to 1948, when the statutory notice of deficiency was sent, that taxpayer, through his counsel, had been advised to protect himself by filing protective claims for refund?

A. Yes, our files do so indicate.

Q. Do you recall approximately what year a letter to that effect was sent to counsel, was it in 1946?

A. The letter that I have in mind was mailed shortly before the statutory notice was issued?

Q. Sometime in 1947?

A. In 1948,—sometime shortly before the statutory notice was issued in May 1948.

Q. Does your file indicate that prior to the issuance of the statutory notice they had been put on notice by letter that they should protect themselves by filing a claim for refund?

A. Yes, and then as has already been testified the statutory notice itself carried further, a paragraph to that effect.



(Testimony of A. N. Williams.)

Q. A second notice was sent in the statutory notice of this deficiency?      A. Yes. [50]

\* \* \* \* \*

#### Recross Examination

Q. (By Mr. Burdick): Just a few questions. Mr. Williams, did you have before you during all these negotiations, in your files, the petition that was filed in the Tax Court by the Plaintiff in this case?

A. Sometimes those files accompany administrative files and at times they do not. In any event they are always available to me and in this case I think it was part of my file.

Q. So that you had before you during these negotiations, the petition that was filed by the Plaintiff in this case?      A. That's right.

Q. That petition I think is exhibit numbered 2?

A. I have it, yes.

Q. I would like to call your attention to page 5 of the petition and ask you to read paragraph K of that?      A. Yes.

Q. Now, did you ever tell the Petitioner's representative here that that wasn't a sufficient claim that the overassessment here was larger than was shown in the statutory notice?

A. I don't remember of that paragraph ever being discussed [52] I don't believe it was. In any event there is no claim in there of overpayment.

Q. But there is a claimed overassessment?

A. That's right.

Q. I call your attention to page 17 of the peti-

(Testimony of A. N. Williams.)

tion, paragraph "A" of the prayer, page 17 which I will read: "That there is an overassessment in Petitioner's excess profits tax for the taxable year ended December 31, 1943 of not less than \$54,218.68 for said year." Now, did you ever tell the representative of the Petitioner that that wasn't a sufficient claim that there was an overassessment in excess profits tax of \$54,218.68, for the year 1943?

A. That provision of the prayer was never discussed to my knowledge.

Q. But you did have this petition in your files?

A. Yes. [53]

\* \* \* \* \*

[Endorsed]: Filed February 15, 1957.

---

[Endorsed]: No. 15419. United States Court of Appeals for the Ninth Circuit. United States of America, Appellant, vs. A. G. Rushlight & Co., a corporation, Appellee. Transcript of Record. Appeal from the United States District Court for the District of Oregon.

Filed: January 23, 1957.

/s/ PAUL P. O'BRIEN,

Clerk of the United States Court of Appeals for the Ninth Circuit.

In the United States Court of Appeals  
for the Ninth Circuit

No. 15419

UNITED STATES OF AMERICA, Appellant,

vs.

A. G. RUSHLIGHT & CO., an Oregon corpora-  
tion, Appellee.

STATEMENT OF POINTS AND DESIGNA-  
TION OF RECORD

Appellant herein hereby files a statement of points on which it intends to rely, which are as follows:

1. The District Court erred in finding that the letter of May 28, 1948, advising the taxpayer of deficiencies in income tax for 1943 and 1944 and the overassessment of excess profits tax for 1943, was ambiguous and misleading as to what steps the taxpayer should take. This letter specifically states that the overassessment for 1943, which is here in issue, would be made the subject of a certificate of overassessment provided that the taxpayer fully protected himself against the running of the statute of limitations by filing a claim for refund on Form 843 with the Collector of Internal Revenue. A copy of this form was enclosed with the letter. Appellant alleges that the language in this letter was clear as to what steps the taxpayer should take in regard the overassessment for 1943.

2. The District Court erred in finding that the petition filed in the Tax Court gave the Commissioner of Internal Revenue sufficient notice of taxpayer's intentions and that the petition adequately set forth a claim for refund for 1943 excess profits taxes. A Tax Court petition cannot qualify as a claim for refund since it is filed with the Tax Court and not with the Commissioner of Internal Revenue, and since it was never identified as a refund claim. A claim for refund is only valid when it is identified as such. Otherwise, the Commissioner of Internal Revenue has nothing before him to accept or reject.

3. The District Court erred in finding that the Commissioner of Internal Revenue investigated the matters set forth in the Tax Court Petition as though it were a claim for refund and, therefore, the formal requirements of the statute and regulations were waived. There is no evidence in the record to show that the District Director's office took any action or verbally indicated to taxpayer that a portion of the petition filed in the Tax Court would suffice as a claim for refund. Merely carrying on negotiations with the District Director's office to redetermine income and excess profits tax deficiencies for both 1943 and 1944 as well as the excess profits tax overassessment for 1943 here involved, does not constitute a waiver of the claim for refund requirements.

Appellant herein hereby designates as the record material to this appeal, the following:

1. Complaint.
2. Answer.
3. Pre-trial Order.
4. Exhibits 1 through 7 attached to the pre-trial order.
5. The following portions of the reporter's transcript of April 27, 1956: Page 10, line 8-16; page 14, line 10 - page 25, line 24; page 33, line 3-23; page 40, line 24 - page 41, line 5; page 48, line 11- page 50, line 25.
6. Opinion of the District Judge.
7. Findings of Fact and Conclusions of Law.
8. Judgment.
9. Notice of Appeal dated October 29, 1956.
10. Notice of Appeal dated January 18, 1957.
11. Order Extending Time to File Record on Appeal, entered December 5, 1956.
12. Designation of Record.
13. This Statement of Points and designations as to contents of record on appeal.

CHARLES K. RICE,

Assistant Attorney General,  
Counsel for Appellant

[Endorsed]: Filed February 2, 1957. Paul P. O'Brien, Clerk.



[Title of U. S. Court of Appeals and Cause.]

APPELLEE'S DESIGNATION OF RECORD

Comes now the Appellee and pursuant to Rule 17 of the rules of this court designates the following portion of the record on appeal as being material to this appeal.

1. The following portions of the reporter's transcript of April 26, 1956:

Page 6, line 25 - page 10, line 7; page 10, line 16 - page 14, line 9; page 26, line 16 - page 33, line 2; page 33, line 24 - page 40, line 18; page 41, line 6 - page 43, line 23; page 52, line 5 - page 53, line 16.

/s/ DENTON G. BURDICK, JR.  
Of Attorneys for Appellee

Affidavit of Service attached.

[Endorsed]: Filed February 12, 1957. Paul P. O'Brien, Clerk.

THE UNIVERSITY OF CHICAGO  
DEPARTMENT OF CHEMISTRY  
58 CHEMISTRY BUILDING  
CHICAGO, ILLINOIS 60637

RECEIVED  
MAY 15 1964  
FROM  
DR. J. H. GOLDSTEIN  
100 UNIVERSITY AVENUE  
CAMBRIDGE, MASSACHUSETTS 02138

RECEIVED  
MAY 15 1964  
FROM  
DR. J. H. GOLDSTEIN  
100 UNIVERSITY AVENUE  
CAMBRIDGE, MASSACHUSETTS 02138

RECEIVED  
MAY 15 1964  
FROM  
DR. J. H. GOLDSTEIN  
100 UNIVERSITY AVENUE  
CAMBRIDGE, MASSACHUSETTS 02138

No. 15423

IN THE

# United States Court of Appeals

FOR THE NINTH CIRCUIT

---

DAVID SEYMOUR GRAVES,

*Appellant,*

*vs.*

UNITED STATES OF AMERICA,

*Appellee.*

---

## APPELLEE'S BRIEF.

---

LAUGHLIN E. WATERS,  
*United States Attorney,*

LOUIS L. ABBOTT,  
*Assistant U. S. Attorney,  
Chief of Criminal Division,*

BRUCE A. BEVAN, JR.,  
*Assistant U. S. Attorney,*

600 Federal Building,  
Los Angeles 12, California,  
*Attorneys for Appellee.*

FILED

JUN 13 1957

PAUL P. O'BRIEN, CLERK

1. The first part of the document discusses the importance of maintaining accurate records of all transactions and activities. It emphasizes that this is essential for ensuring transparency and accountability in the organization's operations.

2. The second part of the document outlines the various methods and tools used to collect and analyze data. It highlights the need for consistent data collection procedures and the use of advanced analytical techniques to derive meaningful insights from the data.

3. The third part of the document focuses on the role of technology in data management and analysis. It discusses how modern software solutions can streamline data collection, storage, and processing, thereby improving efficiency and accuracy.

4. The fourth part of the document addresses the challenges associated with data management, such as data quality, security, and privacy. It provides strategies to mitigate these risks and ensure that the data remains reliable and secure throughout its lifecycle.

5. The fifth part of the document concludes by summarizing the key findings and recommendations. It stresses the importance of a data-driven approach in decision-making and the need for continuous monitoring and improvement of the data management process.

No. 15423

IN THE

# United States Court of Appeals

FOR THE NINTH CIRCUIT

---

DAVID SEYMOUR GRAVES,

*Appellant,*

*vs.*

UNITED STATES OF AMERICA,

*Appellee.*

---

## APPELLEE'S BRIEF.

---

LAUGHLIN E. WATERS,  
*United States Attorney,*

LOUIS L. ABBOTT,  
*Assistant U. S. Attorney,  
Chief of Criminal Division,*

BRUCE A. BEVAN, JR.,  
*Assistant U. S. Attorney,*

600 Federal Building,  
Los Angeles 12, California,  
*Attorneys for Appellee.*

FILED

JUN 13 1957

PAUL P. O'BRYEN, CLERK





## TOPICAL INDEX

	PAGE
Statement of jurisdiction.....	1
Statement of the case.....	2
I.	
Appellant's conviction for failing to report for induction was proper .....	5
A.	
Appellant was under a continuing duty to report for induction	5
B.	
Appellant knowingly failed to fulfill his continuing duty to report for induction.....	8
II.	
Reception of the Selective Service file into evidence was not error .....	10
III.	
Appellant was not entitled to a judicial review of his classification since he failed to exhaust his administrative remedies.....	12
Conclusion .....	21

## TABLE OF AUTHORITIES CITED

CASES	PAGE
Alvarado v. United States, 9 F. 2d 385.....	11
Billings v. Truesdell, 321 U. S. 542.....	14, 15, 16
Buhler v. United States, 33 F. 2d 382.....	11
Chernekov v. United States, 219 F. 2d 721.....	16
Cox v. United States, 332 U. S. 442.....	12
Crono v. United States, 59 F. 2d 339.....	11
Falbo v. United States, 320 U. S. 549.....	13, 20
Fink v. United States, 142 F. 2d 443.....	11
Francy v. United States, 217 F. 2d 751.....	16
Gibson v. United States, 329 U. S. 338.....	20
Kalpakoff v. United States, 217 F. 2d 748.....	16
Mason v. United States, 218 F. 2d 375.....	16, 18
Penor v. United States, 167 F. 2d 553.....	13
Reed v. United States, 205 F. 2d 216, cert. den. 346 U. S. 908....	12
Silverman v. United States, 220 F. 2d 36.....	6, 7
Touhy v. United States, 88 F. 2d 930.....	11
Tyrell v. United States, 200 F. 2d 8.....	12, 13
United States v. McIntyre, 4 F. 2d 823.....	7
United States v. Sutter, 127 Fed. Supp. 109.....	6
Williams v. United States, 203 F. 2d 85.....	13, 14

### REGULATIONS AND RULES

Army Special Regulations, Special Regulation 615-100-1.....	18
Army Special Regulations, Special Regulation 615-180-1.....	19
32 Code of Federal Regulations, Sec. 1622.24(a).....	13
32 Code of Federal Regulations, Sec. 1628.10.....	18
32 Code of Federal Regulations, Sec. 1628.25(1).....	18
32 Code of Federal Regulations, Sec. 1631.7.....	18
32 Code of Federal Regulations, Sec. 1632.14(a).....	5, 7

	PAGE
32 Code of Federal Regulations, Sec. 1632.14(b) .....	18
32 Code of Federal Regulations, Sec. 1632.15(e) .....	18
32 Code of Federal Regulations, Sec. 1632.20(a) (3) .....	18
32 Code of Federal Regulations, Sec. 1632.20(b) (3).....	18
32 Code of Federal Regulations, Sec. 1632.21(b) .....	18
32 Code of Federal Regulations, Sec. 1632.30 .....	18
32 Code of Federal Regulations, Sec. 1641.3 .....	7
32 Code of Federal Regulations, Sec. 1642.2 .....	6
Federal Rules of Criminal Procedure, Rule 37.....	2
Federal Rules of Criminal Procedure, Rule 39.....	2

#### STATUTES

United States Code, Title 28, Sec. 1291.....	2
United States Code, Title 50, App., Sec. 462(a).....	2





No. 15423

IN THE

# United States Court of Appeals

FOR THE NINTH CIRCUIT

---

DAVID SEYMOUR GRAVES,

*Appellant,*

*vs.*

UNITED STATES OF AMERICA,

*Appellee.*

---

## APPELLEE'S BRIEF.

---

### Statement of Jurisdiction.

Appellant was indicted by the Grand Jury for the Southern District of California on February 23, 1956. [Tr. R. 2-3.]<sup>1</sup>

On March 5, 1956, appellant was arraigned on the charge in the indictment and on April 9, 1956, pleaded not guilty thereto. [Tr. R. 4.] Jury trial began on April 24, 1956, and was concluded by a verdict of guilty on April 25, 1956. [R. T. 3, 172.] After several requests for postponement by appellant, in order to liquidate his business, he was sentenced on September 24, 1956, at which

---

<sup>1</sup>Tr. R. refers to the Clerk's Transcript of Record; R. T. refers to Reporter's Transcript of Proceedings; SSF refers to appellant's Selective Service File, Plaintiff's Exhibit 1.

time it was adjudged that he be committed to the custody of the Attorney General for a period of one year and one day. [Tr. R. 19.]

On September 24, 1956, the District Court ordered that appellant remain at liberty on his own recognizance pending the determination of his appeal. [Tr. R. 21.] A timely notice of appeal was filed on September 24, 1956. [Tr. R. 22.] On February 18, 1957, Chief Judge Denman ordered that appellant could proceed upon a typewritten record and typewritten briefs.<sup>2</sup>

The District Court had jurisdiction of this action under the provisions of United States Code, Title 50 App. Section 462(a).

This Court has jurisdiction under the provisions of United States Code, Title 28, Section 1291, and Rules 37 and 39 of the Federal Rules of Criminal Procedure, United States Code Annotated, Title 18.

### Statement of the Case.

Appellant registered for the draft on July 18, 1950, and was classified II-C on May 23, 1951. [SSF 3.] He received a 1-A classification on March 10, 1954, which was sustained by the Appeal Board on May 14, 1954. [SSF 3, 13.]

---

<sup>2</sup>Appellee received notice of appellant's Application for Leave to Proceed upon Typewritten Record and Typewritten Briefs on February 18, 1957, and notice that this Court had granted the Application on February 19, 1957. Appellee thus was unable to oppose the Application in time and to point out to the Court that although appellant had stated in his affidavit that he did not have the money with which to pay the costs of printing the record and briefs on appeal, the probation report in the District Court reflected that as of September 19, 1956 appellant's assets exceeded his liabilities by \$15,050. Cf. SSF 112, 115.

On July 15, 1954, appellant was given a personal hearing before the local board at which time he was told that he must serve in the armed forces at some time and was therefore advised to make arrangements for the disposition of his bee business. [SSF 49.] When the board asked appellant when he would be in a financial position to go into the service, he replied he needed a year. [SSF 50.] The 1-A classification was continued on July 15, 1954, from which the appellant appealed. The Appeal Board again sustained the classification on September 2, 1954.

Appellant was given a pre-induction physical examination on November 23, 1954, and was found acceptable for military service. [SSF 68, 69, 81.]

On January 17, 1955, appellant came into the office of the local board and stated that he did not want to go into the service, among other things. He further advised the board that he could not enter the service until at least September, 1955. [SSF 83-84.]

On August 23, 1955, appellant was ordered to report for induction on September 8, 1955. [SSF 88.] Appellant requested a 30-day extension of that order. [SSF 89, R. T. 106, 109.] On August 30, 1955, appellant was informed that his induction was postponed until the October, 1955, induction call in order to give him the requested time to arrange his personal affairs. [SSF 91, R. T. 107, 149.] On September 15, 1955, appellant's mother wrote the local board requesting some action whereby appellant could continue to conduct his bee business, but this request was denied on the same date. [SSF 94-96.] In this letter, it was stated that "we have 2500 colonies of bees, three trucks with hoists, one warehouse with equipment." [SSF 94.] Thus the number of colonies

had increased from 2,000 in June, 1954, to 2,500 in 1955, during the time appellant had gained by his requested postponements for the purported purpose of liquidating his bee business. [SSF 38, 39.]

On September 23, 1955, appellant was ordered to report for induction on October 6, 1955, which order appellant admits receiving. [SSF 98, R. T. 110.] On October 5, 1955, some member of appellant's family and his attorney requested from a board member a further postponement of induction but the member stated that any further postponement must be up to the State Director. [SSF 99.] Appellant's counsel later advised the board the same day that appellant was not in town and could not be contacted. [SSF 100.]

On October 7, 1955, appellant's mother wrote the board advising it that "for the past five days" appellant had been in Bakersfield and that he was not aware that he had to report on October 6, 1955, due to a misunderstanding as to what a local board member had told them regarding a requested postponement. Appellant's mother then requested the board to adopt a plan whereby appellant could both operate his bee business and also engage in military training. [SSF 102-104.] On October 7, 1955, appellant's counsel wrote a letter to the board requesting a further postponement of one and one-half years. [SSF 105-106.]

On October 10, 1955, the board wrote a "final directive" to appellant's last known address ordering that he report for induction on October 13, 1955. [SSF 108.] Appellant failed to do so [SSF 120] since he did not return to his home until October 27, 1955. [R. T. 76.] Appellant never reported to the board or to the induction station or to the bus depot for transportation to said station. [R. T.

86-88.] However, his mother came into the local board on October 28, 1955, and requested a further deferment for her son, stating she was not going to have her home and family situation disrupted by the Army. [SSF 122.] At this point, she offered to let her younger son enter the service as a substitute for appellant. [SSF 122, R. T. 77-78.]

It was for the failure to report for induction on October 13, 1955, that the appellant was indicted.

I.

**Appellant's Conviction for Failing to Report for Induction Was Proper.**

A.

**Appellant Was Under a Continuing Duty to Report for Induction.**

Appellant received the Notice to Report for Induction approximately 14 days after the induction date of October 13, 1955. [R. T. 76, 119.] The jury was instructed that in order for appellant to have "knowingly" failed to report for induction, he must first have had knowledge of his duty to report and thereafter failed to report. [R. T. 168.] Appellant contends that such an instruction was erroneous. Appellant does not contend that there cannot be a "continuing duty" to report, but that the law as to continuing duty was not applicable to this case. (Appellant's Br. p. 30.)

32 C. F. R., Sec. 1632.14(a) provides:

"When the local board mails to a registrant an Order to Report for Induction . . . , it shall be the duty of the registrant to report for induction at the time and place fixed in such order . . . . Regardless of the time when or the circumstances under



which a registrant fails to report for induction when it is his duty to do so, it shall thereafter be his continuing duty from day to day to report for induction to his local board and to each local board whose area he enters or in whose area he remains.”

It is also provided in 32 C. F. R., Sec. 1642.2:

“Continuing duty. When it becomes the duty of a registrant or other person to perform an act . . . , the duty or obligation shall be a continuing duty or obligation from day to day . . . .”

No attack is made on these regulations which were the bases of the alleged erroneous instructions set forth at pages 17-19 of Appellant’s Brief. Therefore, the validity of such regulations should herein be presumed. In any event, their validity has been upheld in *Silverman v. United States*, 220 F. 2d 36, 39 (C. A. 8, 1955), wherein it was stated:

“The nature of the offense charged is such that it may upon proper proof be a continuing one . . . . The offense charged and proved was a continuing one. There was no error in so instructing the jury.”

*Cf. United States v. Sutter*, 127 Fed. Supp. 109 (D. C. Calif. 1954).

Appellant’s primary contention with respect to this matter, other than that there was insufficient evidence upon which to base the jury verdict, is that appellant had no “duty” to report on October 13, 1955, since he never had notice of the Order to Report until after that date. Thus, there never existed any duty which could “continue.” As interesting as this theory is, it has a false premise, since it assumes that a registrant has no “duty”

to report unless he has knowledge of that requirement. As the above-quoted 32 C. F. R., Sec. 1632.14(a) provides distinctly, the duty of a registrant to report occurs *at the time* the local board mails an order to report for induction. Moreover, although actual knowledge thereof might be a requisite to criminal prosecution, the mere fact of mailing constitutes “notice” under 32 C. F. R., Sec. 1641.3, which states:

“. . . The mailing of any order, notice, or blank form by the local board to a registrant at the address last reported by him to the local board shall constitute notice to him of the contents of the communication, whether he actually receives it or not.”

*Cf. United States v. McIntyre*, 4 F. 2d 823 (C. C. A. 9, 1925).

Thus, the unchallenged regulations themselves provide the answer to appellant’s contention that there was no duty which could continue. The regulations unequivocally state that appellant’s duty to report arose upon the mailing of the order to report, and that thereafter, it remained his continuing duty to report. Once appellant had actual knowledge of his duty, and thereafter knowingly failed to report, the offense was complete.

The aforementioned *Silverman* case necessarily so holds, since the conviction therein was for failing to report for induction on June 8, 1951, even though Silverman did not receive said order, and had notice thereof only after said date. Therefore, it is clear that the instant appellant had a duty to report on October 13, 1955, and that if, as the jury so decided, he had knowledge thereafter of his duty and knowingly failed to perform it, he was guilty of the offense.

B.

**Appellant Knowingly Failed to Fulfill His Continuing Duty to Report for Induction.**

Although not pressed with vigor in his brief, appellant nevertheless has raised the question of the sufficiency of the evidence before the jury. (Appellant's Br. pp. 8, 30.) Some of the evidence is set forth below which the jury could have considered in concluding that appellant, after receiving notice on October 27, 1955, of his call to induction, knowingly failed to perform his continuing duty to report.

Appellant's mother testified that appellant received the order to report when he returned from Bakersfield on October 27, 1955, and that

“I do remember distinctly David telling me he didn't want to go in . . .” [R. T. 143.]

Although he drove his mother to the office of the local board on October 28, 1955, appellant did not go inside when his mother therein requested a further deferment for him [SSF 122], for the reason that

“Well, they had abused me so much, I just didn't want to see them again . . .” [R. T. 85.]

Appellant freely conceded that he made no further attempt to contact the local board except by an unsuccessful attempt to phone a board member, since he did not want to talk to the board anymore. [R. T. 86-87.] Further, appellant did not report to the induction station or to the bus depot for transportation thereto, after he received his order to report. [R. T. 88.]

The jury also could consider the appellant left San Bernardino about October 2, 1955, without notifying the

board of a change of address, even though he knew he was under orders to report for induction on October 6, 1955. [SSF 98, 102-104; R. T. 110.] In connection therewith, the jury also could consider that appellant had previously requested and obtained extensions of induction of one year and of one month in order to liquidate his bee business [SSF 49-50, 88, 98, 91], but had purchased 400 queen bees in late September or October, 1955, contemplating that he would be available to utilize them in his business during the Spring of 1956. [R. T. 105, 112-113, 123.] Therefore, it was reasonable for the jury to infer that appellant never intended to report for induction and that he knowingly refused to obey every order of the local board to do so.

Appellant's attitude towards military service and the attempts of the Selective Service System to draft him probably were revealed to the jury when he stated that he "might have" called the F.B.I. agents who arrested him a couple of gestapo agents, and told them that he had a business to maintain and that he would not be willing to report for induction without a warrant of arrest. [R. T. 9-10, 89-90.] When asked the ultimate question as to whether, on the day he drove his mother to the draft board on October 28, 1955, he was willing to submit to induction, appellant replied

"How am I supposed to know how I felt then . . ."  
[R. T. 124.]

The jury had ample evidence before it sufficient to support their verdict of guilty. The fact that appellant's mother requested a further deferment for her son on the day he returned from Bakersfield cannot operate as a compliance with appellant's duty to report. Although his

mother participated heavily in the induction affairs of appellant, the one thing she could not do for him was to perform his duty of reporting for induction.

## II.

### Reception of the Selective Service File Into Evidence Was Not Error.

One of appellant's specifications of error is that the Court erred in admitting into evidence pages 119 through 122 of the Selective Service file on the grounds that the documents set forth on those pages were hearsay. Perhaps this alleged error is not urged too strongly in view of the lack of argument thereon, but in any event, the question will be answered by appellee.

Of course, most of what makes up a Selective Service file is pure hearsay, and appellant in his brief is not above making full use of such hearsay documents in support of his contentions that appellant was a "qualified and experienced beekeeper" in a "highly specialized work" which was helpful in the national defense by reason of the "use of beeswax in airplanes and for the rifling of big guns in 'mothballs.'" [Appellant's Br. p. 2; SSF 22, 26, 38 and 39.]

But one need not dwell too long on this facet of the case, since appellant's counsel later in the trial completely waived his previous objections [T. 6] to use of all the Selective Service file. [T. 132, 153.] At page 153 of the Reporter's Transcript, the following colloquy occurred:

"Q. (Mr. Bevan): Let's refer to page 122, Mrs. Graves, of Exhibit 1 in evidence. I think you looked at this exhibit yesterday rather thoroughly. A. Oh, yes.



Q. With respect—

Mr. Tietz: I will object to the use of that in an effort to impeach the witness in that it is not what she said but it is what somebody else has put in here as their own impression.

\* \* \* \* \*

The Court: It is part of the record. It is all admitted in evidence.

Mr. Tietz: That proof should be brought in. The question is, your Honor, for what purpose it may be used.

The Court: It was not restricted at all. It was all admitted in evidence.

Mr. Tietz: Then whatever is in evidence may be used for argument to the jury?

The Court: Absolutely. That's right.

Mr. Tietz: Under those circumstances, I will let him have full leeway.

Mr. Bevan: You fully consent to having this file be used and having the jury use the file?

Mr. Tietz: Oh, certainly."

Since whatever objection was made in the court below was withdrawn, it cannot here be raised.

*Touhy v. United States*, 88 F. 2d 930, 934 (C. C. A. 8, 1937).

*Cf. Fink v. United States*, 142 F. 2d 443 (C. C. A. 9, 1943);

*Crono v. United States*, 59 F. 2d 339 (C. C. A. 9, 1932);

*Buhler v. United States*, 33 F. 2d 382 (C. C. A. 9, 1929);

*Alvarado v. United States*, 9 F. 2d 385 (C. C. A. 9, 1925).

III.

**Appellant Was Not Entitled to a Judicial Review of His Classification Since He Failed to Exhaust His Administrative Remedies.**

At the outset, appellant's argument with respect to the trial court's failure to submit instructions to the jury bearing upon the 1-A classification should be disposed of. If appellant did exhaust his administrative remedies, he would be entitled to raise the issue of erroneous classification, but only to a court and not to a jury. It is well-established that the question of whether a basis in fact existed for an alleged erroneous classification is one which must not be submitted to a jury.

*Cox v. United States*, 332 U. S. 442 (1947);

*Reed v. United States*, 205 F. 2d 216 (C. A. 9, 1953), cert. den., 346 U. S. 908;

*Tyrrell v. United States*, 200 F. 2d 8 (C. A. 9, 1953).

Therefore, no error was committed by the failure to give to the jury appellant's requested instructions.

Appellant's argument as to the arbitrary nature of the 1-A classification, given March 10, 1954, is that no basis in fact existed for changing appellant's II-C (agricultural deferment) classification given him on February 23, 1951. The importance of beekeeping, appellant says, is, *inter alia*, the use of beeswax in airplanes and cannons. The mere fact of the ending of the Korean hostilities on July 27, 1953, would appear to be sufficient reason for ending the exemption which is granted to a "registrant who is employed in the production for market of a substantial quantity of those agricultural commodities which are

necessary to the maintenance (*sic*) of the national health, safety or interest.” (32 C. F. R., Sec. 1622.24(a); *Cf. Tyrrell v. United States*, 200 F. 2d 8, 12 (C. A. 9, 1953).)

However, further arguments as to the reasonableness of the classification will not be advanced, as that question never reached the trial court. It is well-settled, and not disputed herein, that in order for a registrant to be entitled to a judicial review of his classification, he first must have exhausted his administrative remedies.

*Falbo v. United States*, 320 U. S. 549 (1943);

*Williams v. United States*, 203 F. 2d 85 (C. A. 9, 1953);

*Penor v. United States*, 167 F. 2d 553 (C. C. A. 9, 1948).

The issue in the instant case is whether, in fact, appellant exhausted his administrative remedies. On October 23, 1954, appellant was given a preinduction physical and found acceptable for military service. [SSF 62-81.] Appellant was ordered to report for induction on October 13, 1955, which he failed to do. It is appellant's argument that his administrative remedies were exhausted as of October 23, 1954, since, being found acceptable, there remained nothing for the Army to do but induct him on the later date. If this contention be correct, a fundamental change in the concept of the induction process must have been worked by the preinduction physical examination procedure, since the law before such procedures were enacted required registrants to appear at the induction station before it was said that administrative remedies were exhausted.

As this Court very clearly stated in *Williams v. United States*, 203 F. 2d 85, 88 (C. A. 9, 1953):

“Furthermore, as the Supreme Court pointed out in *Estep v. United States* supra, the Selective Service Act requires a selectee to come to the brink of induction before he may obtain a judicial review of his classification. He must . . . take the symbolic ‘one step forward’ which signifies that he has complied with all the steps in the selective process. *Only then will judicial review of an alleged violation of a selectee’s constitutional rights by his local Board be available.*” (Emphasis added.)

The case law and applicable regulations demonstrate unequivocally, however, that no such change has occurred.

The question in *Billings v. Truesdell*, 321 U. S. 542 (1944), was whether a registrant who had reported to the induction station, had there undergone physical and mental examinations, but who had not undergone the ceremony of induction, was under a limited form of military jurisdiction. The Supreme Court said that he was not, and in doing so, shed considerable light upon the question before this Court. After his examinations at the induction station, Billings was found “acceptable” for service, and the Government contended that he became a soldier as of that time. The Court, however, pointed out the distinctions between a registrant who had been found “acceptable” and one who had been “inducted,” analogizing to the then new regulations (not applicable to Billings) as to preinduction physical examinations which also provided, prior to induction, for one being found “acceptable.”

“Moreover, the Selective Service Regulations have been amended in recent months so as to provide for preinduction physical examinations before a registrant ‘is ordered to report for induction.’ . . . Those found acceptable by the Army or Navy are later ordered to report for induction.

\* \* \* \* \*

“We mention these recent regulations because they perpetuate the distinction between acceptance or being found acceptable and induction which appeared in the regulations when Billings reported at the induction station. That these amendments do not effect any change in the concept of induction is apparent from the fact that its definition has remained practically the same from the time when Billings reported at the induction station to the present time. *It could hardly be maintained that a selectee who has passed his preinduction physical examination but who has not been ordered to report for induction is subject to military jurisdiction.*

\* \* \* \* \*

“Moreover, it should be remembered that he who reports at the induction station is following the procedure outlined in the *Falbo* case for the exhaustion of his administrative remedies. *Unless he follows that procedure he may not challenge the legality of his classification in the courts.*” (Emphasis added.)

The *Billings* decision plainly recognizes that a registrant is found “acceptable” by the Army after a preinduction physical examination—yet equally plainly states that such registrant nevertheless must report to the induction station in order to exhaust his administrative remedies so as to raise the issue of his classification in court. Appellant’s argument that his acceptance by the Army on



October 23, 1954, constituted an exhaustion of his administrative remedies is in direct conflict with the utterances of the Supreme Court. If the dictum of *Billings* is to be set aside, it should be done by that Court, and no other.

This Court does not disagree with the foregoing statements in *Billings*, because in *Mason v. United States*, 218 F. 2d 375, 380 (C. A. 9, 1954), it was remarked:

“Finally it cannot be argued that the provision for Mason’s preinduction physical examination completed, at that stage, the administrative process of determining whether he shall be selected for military service. A similar argument was rejected in *Billings v. Truesdell* . . . The court there held that the regulations relating to a preinduction physical examination did not effect any change in the concept of ‘induction.’”

The *Mason* decision was followed in *Kalpakoff v. United States*, 217 F. 2d 748 (C. A. 9, 1954), and *Francy v. United States*, 217 F. 2d 751 (C. A. 9, 1954). This Court has emphasized the importance of the process at the induction station and, impliedly, the importance of the registrant being there to exhaust his administrative remedies. *Chernehoff v. United States*, 219 F. 2d 721 (C. A. 9, 1955), contains the following language:

“Appellant reported to the induction station as required by 32 Code Fed. Regs. §1632.14(a). He thus exhausted his administrative remedies . . . As 32 Code Fed. Regs. §1632.16 does not prescribe any method for induction, the Department of the Army has specified the procedure to be followed in Special Regulation 615-180-1.

“One purpose of this regulation is self-evident. It is intended to give a registrant a last clear chance to change his mind and accept induction rather than certain indictment and possible conviction for a felony . . .

“In the present case, the appellant was not given the prescribed step forward, nor the prescribed warning . . . it is highly important that the moment a selectee becomes subject to military authority be marked with certainty. It is also important that the moment he becomes liable for civil prosecution be marked with certainty . . .

“The ceremony is designed to bring about a definite responsive course of conduct by the selectee marking his separation from his civil status. This ceremony must be conformed to unless the selectee himself makes it impossible . . . or unnecessary . . .”  
(Emphasis added.)

Since Chernekoff was not given a definite opportunity to be inducted or refuse to be inducted at the proper time, the judgment of his conviction was reversed, even though Chernekoff, at the induction station, had made a written refusal to be inducted. Such being the importance of the culmination of the selective process, it stands to reason that the exhaustion of administrative remedies would require that the registrant go to the induction station even though it might be a foregone conclusion that he would be inducted there.

It is not necessary that the instant decision go that far, however, since appellant still might have been rejected for military service at the induction station. The Selective Service and Army regulations show this very clearly. With certain exceptions not herein pertinent, the appropriate draft procedures are set forth below.

Every registrant is given a preinduction physical before being ordered to report for induction. (32 C. F. R., Sec. 1628.10.) A Certificate of Acceptability is placed in the files of those registrants found acceptable for military service. (32 C. F. R., Sec. 1628.25(1).) Only those registrants found acceptable after a preinduction physical are selected to report for induction. (32 C. F. R., Sec. 1631.7.) Nevertheless, the selective process provides for the rejection of such "acceptable" selectees. For example, selectees who are rejected at the station must follow the armed forces instructions as to their return (32 C. F. R., Sec. 1632.14(b)), they are provided transportation and subsistence for their return trip (32 C. F. R., Sec. 1632.15 (e)), records of the rejections go into their files (32 C. F. R., Sec. 1632.20(a)(3)), and various other steps must be taken by the Selective Service System and by the armed forces concerning such rejected selectees. (32 C. F. R., Secs. 1632.20(b)(3), 1632.21(b), 1632.30.) The reasons for possible rejection of "accepted" selectees may be obtained from the Army Special Regulations governing induction procedures.

As appellant states in his Brief, the Army Special regulations in effect at the time of his induction-order date were the same as those set forth in *Mason v. United States, supra*, or Special Regulation 615-100-1. That Regulation stated:

"As provided by SR 615-180-1, registrants found acceptable for military service or pre-induction examination and reporting for induction will undergo a physical inspection if the induction is accomplished within . . . a year in case of postponed registrants, after the pre-induction examinations."

As stated in the foregoing Regulation, Special Regulation 615-180-1 determines the procedures applicable to induction processing and physical inspection, and provides:

“17. *Scope of induction processing.*—Steps in processing acceptable registrants are listed below and normally will be performed in the order indicated.

- “a. Reception of registrants and records.
- “b. Induction orientation talk.
- “c. Roll call and issuance of individual records.
- “d. Physical inspection.
- “e. Allocation to Army, Navy, or Air Force.
- “f. The induction.
- “g. Oath of allegiance ceremony.
- “h. Outprocessing.

\* \* \* \* \*

“21. *Physical Inspection.*—a. Registrants found acceptable for military service on preinduction physical examination and reporting to an induction station for induction . . . will be medically processed by the examining physician as follows:

- (1) Physical inspection.—Registrants will be given a thorough physical inspection, with all clothing removed, for contagious diseases, apparent defects, and intercurrent illness or injuries.

“21.c.(2)—For registrants found unacceptable on physical inspection.—In cases of registrants found unacceptable on physical inspection, the disqualifying defects will be listed under item 73 in order of seriousness, carrying the following heading: ‘Disqualifying defects discovered upon inspection.’ The following additional statement will be made under the same item: ‘Unfit for military service.’

“27.f. Processing steps for registrants found unacceptable on physical inspection.—For registrants found unacceptable for military service on physical inspection, processing will be completed as follows:

\* \* \* \* \*

- (6) Registrants will be directed to the transportation section where arrangements will be made for returning them to the appropriate Selective Service local boards. Every effort will be made to place the registrants on return transportation on the same day of their arrival at the induction station.”

This, it is quite apparent that a registrant found “acceptable” after a pre-induction physical examination may be rejected at the induction station. Of course, it is not a registrant’s actual physical condition which is important, but the fact that a change of physical condition might have occurred resulting in a rejection, which is of controlling importance. *Gibson v. United States*, 329 U. S. 338, 345 (1946). The rationale of the cases which require exhaustion of administrative remedies before seeking judicial relief is that the “selectee may still be rejected at the induction station.” *Falbo v. United States*, *supra*, at p. 553. In view of the fact that appellant might still have been rejected at the induction station, the conclusion appears inescapable that he failed to exhaust his administrative remedies by not appearing there. Thus, the trial court did not err in its refusal to pass upon the question of whether appellant’s 1-A classification had a basis in fact.



### Conclusion.

This is not the ordinary case of a conscientious objector. Instead, the evidence at trial demonstrates that economic and not religious motives lay behind appellant's deliberate and brazen refusal to be inducted into the armed forces. Although appellant's absence from his place of address to which the orders to report for induction were sent, probably was a deliberate attempt to evade military service, no proof thereof was presented to the jury, except by way of the logical inferences they could draw from the evidence. Thus, the Government's proof in and theory of the prosecution were not bottomed on appellant's failures to report on October 6, 1955 and October 13, 1955, but upon the fact that appellant received actual notice of the latter order to report on October 27, 1955. Having been aware of the call to induction, appellant's refusal thereafter to take any steps toward submitting to induction was a violation of his continuing duty to report. By failing to report, appellant also waived any right he may have had to question in court his 1-A classification.

The judgment of the District Court should be affirmed.

Respectfully submitted,

LAUGHLIN E. WATERS,

*United States Attorney,*

RICHARD A. LAVINE,

*Assistant U. S. Attorney,*

*Chief, Civil Division,*

BRUCE A. BEVAN, JR.,

*Assistant U. S. Attorney,*

*Attorneys for Appellee.*

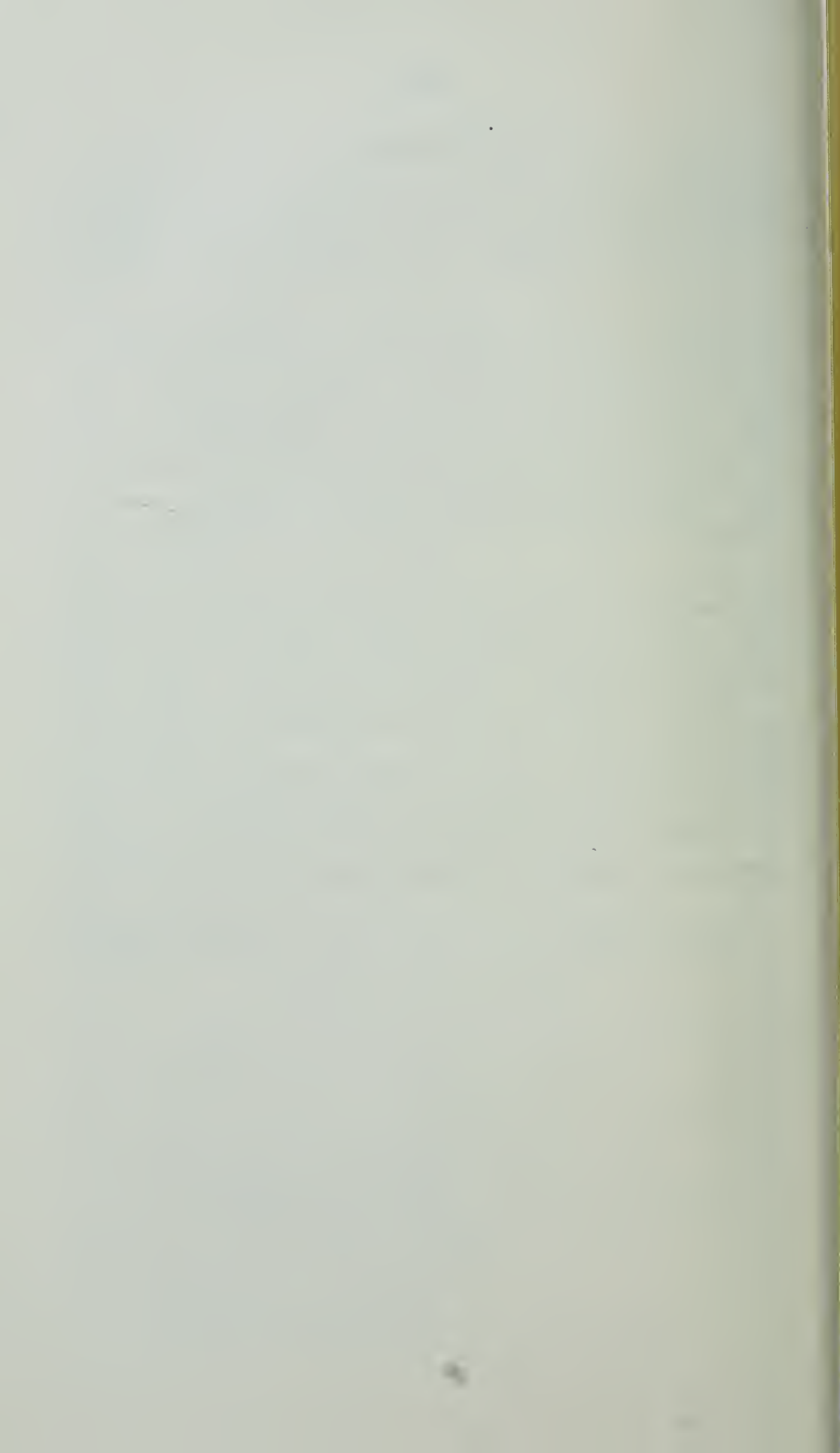

No. 15424

IN THE

# United States Court of Appeals

FOR THE NINTH CIRCUIT

---

FOX WEST COAST THEATRES CORPORATION, TWENTIETH  
CENTURY-FOX FILM CORPORATION, AND LOEW'S IN-  
CORPORATED,

*Appellants,*

*vs.*

PARADISE THEATRE BUILDING CORP.,

*Appellee.*

---

BRIEF OF APPELLEE PARADISE THEATRE  
BUILDING CORP.

---

WELLER & CORINBLIT,

ELWOOD KENDRICK,

JOSEPH ALIOTO,

By JACK CORINBLIT,

3325 Wilshire Boulevard,

Los Angeles 5, California,

*Attorneys for Appellee.*

**FILED**

NOV 19 1957

PAUL P. O'BRIEN, CLERK



## TOPICAL INDEX

	PAGE
Jurisdictional statement .....	1
Statement of the case.....	1
Argument .....	4
I.	
Background of the conspiracy.....	4
A. Fox West Coast excluded competitors from Westchester	5
B. Day and date exhibition in the Los Angeles area.....	7
C. Patronage potential in Westchester for early runs.....	9
D. The Paradise was excellently suited for first run or seven-day run operation.....	11
II.	
There was substantial evidence of a conspiracy among appel- lants to unreasonably restrain and monopolize trade in licensing motion pictures to appellee on the seven-day avail- ability in Westchester.	
As the proximate result of that conspiracy (1) appellee was excluded from obtaining motion pictures for exhibition on a seven-day availability day and date with Inglewood; (2) appellee was excluded from obtaining motion pictures on a seven-day availability on any terms.....	12
A. The impact of the conspiracy upon the Paradise Theatre	21
B. The reason for the refusal.....	25
C. There was substantial evidence that pursuant to the conspiracy, appellant imposed upon the Paradise (a) unreasonable clearance and (b) the unreasonable re- quirement of so-called "bidding" against non-competitive theatres in Inglewood.....	27



ii.

PAGE

D. The evidence that the Paradise and Inglewood theatres were not in substantial competition..... 29

E. The conspiracy prevented the Paradise Theatre from operating on a regular seven-day run policy, forced it to run old pictures or split availability programs and thus caused a loss to the Paradise Theatre of approximately \$38,000.00 ..... 36

III.

The rules of law applicable to this case require the court to sustain the verdict of the jury and judgment below..... 39

A. The conspiracy issue..... 41

B. Substantial evidence supported the jury's verdict that the appellants conspired to impose unreasonable clearance against the Paradise Theatre..... 56

C. The issue of bidding..... 62

IV.

There was substantial evidence of the fact of damage to appellee's business and property..... 66

A. Appellants failed to carry their burden of proof with respect to the issue of mitigation of damages..... 70

V.

There was neither reversible error nor prejudice to the appellants in the court's addition of the language "in the absence of a conspiracy" to appellants' proposed instructions 26, 31a, 34, 31 and 11..... 73

Conclusion ..... 86

## TABLE OF AUTHORITIES CITED

CASES	PAGE
American Tobacco Co. v. United States, 328 U. S. 781, 66 S. Ct. 1125, 90 L. Ed. 1575.....	52
Bigelow v. RKO-Radio Pictures, 327 U. S. 251.....	69
Bordenaro Bros. Theatres v. Paramount Pictures, Inc., 176 F. 2d 594 .....	46
Bryson v. United States, 238 F. 2d 657.....	45
Cape Cod Food Products v. National Cranberry Association, 119 Fed. Supp. 900.....	54
Fidelity & Casualty Co. of New York v. Griner, 44 F. 2d 706....	39
Flintkote Company v. Lysfjord, et al., Mar. 29, 1957, ..... F. 2d ....., No. 15005.....	50, 69 83, 84, 85, 86, 87
Gunning v. Cooley, 281 U. S. 90, 50 S. Ct. 231, 74 L. Ed. 720 .....	4, 39
J. J. Theatres, Inc. v. 20th Century-Fox Film Corp., 212 F. 2d 840 .....	57
Kellett Aircraft Corp., In re, 186 F. 2d 97.....	71
Kiefer Stewart Co. v. Joseph F. Seagram & Sons, Inc., 332 U. S. 218.....	56
Kobe v. Dempsey Pump Co., 198 F. 2d 416.....	54
Las Vegas Plumbing Association v. United States, 210 F. 2d 732 .....	40
Lorain Journal Co. v. United States, 342 U. S. 143.....	83
Milwaukee Town v. Loew's, 190 F. 2d 561.....	56, 69
Noerr Freight v. Eastern Railroad Presidents Association, 113 Fed. Supp. 737.....	54
Parmelee Transportation Co. v. Keeshin, 144 Fed. Supp. 480....	53, 54
Tennant v. Peoria and Pekin Union Railroad Co., 321 U. S. 29, 88 L. Ed. 520.....	40
United States v. International Fur Workers Union, 100 F. 2d 547 .....	84

	PAGE
United States v. Paramount, et al., 70 Fed. Supp. 53.....	5, 14
United States v. Paramount, et al., 334 U. S. 131.....	56, 63
United States v. Timkin Roller Bearing Co., 341 U. S. 593.....	56
United West Coast Theatres Corp. v. Southside Inc., 178 F. 2d 648 .....	5, 6
William Goldman Theatres v. Loew's, 150 F. 2d 738.....	69
William Goldman Theatres, Inc. v. 20th Century-Fox Film Corp., U. S. D. C., E. D. Pa., Feb. 11, 1957, CCH Trade Rec., par. 68,638.....	64
Wolff v. National Lead Co., 225 F. 2d 427.....	68

#### RULES

Rules of the United States District Court of Appeals, Ninth Circuit, Rule 18(2).....	74, 79
Rules of the United States District Court of Appeals, Ninth Circuit, Rule 18(d).....	76

#### STATUTES

Clayton Act, Sec. 4.....	2
Sherman Act, Sec. 1.....	2
Sherman Act, Sec. 2.....	2
United States Code, Title 15, Sec. 1.....	2
United States Code, Title 15, Sec. 2.....	2
United States Code, Title 15, Sec. 15.....	2







No. 15424

IN THE

# United States Court of Appeals

FOR THE NINTH CIRCUIT

---

FOX WEST COAST THEATRES CORPORATION, TWENTIETH  
CENTURY-FOX FILM CORPORATION, AND LOEW'S IN-  
CORPORATED,

*Appellants,*

*vs.*

PARADISE THEATRE BUILDING CORP.,

*Appellee.*

---

BRIEF OF APPELLEE PARADISE THEATRE  
BUILDING CORP.

---

## Jurisdictional Statement.

The Statement of jurisdiction of appellants, Fox West Coast Theatres (hereinafter referred to as Fox West Coast), Loew's, Inc. (hereinafter referred to as Loew's) and 20th Century-Fox Film Corporation (hereinafter referred to as 20th-Fox), adequately states the basis upon which jurisdiction of the District Court and of this Court are based.

## Statement of the Case.

The statement of the case and the statement of the facts by appellants are both inadequate and misleading so that a full presentation of these matters is required to be made by appellee.

The amended complaint alleged that the appellants (together with the Warner, Universal and Paramount defendants) injured appellee in its business and property

by reason of their violation of Sections 1 and 2 of the Sherman Act (15 U. S. C., Secs. 1 and 2) [R. 26-36].

Section 4 of the Clayton Act (15 U. S. C., Sec. 15) provides that any person injured in his business or property by reason of anything forbidden by the antitrust laws may recover damages therefor, trebled under the statute, together with costs, including a reasonable attorney's fee. The complaint alleged that the injury to the operation of the Paradise Theatre in Westchester, which is part of the City of Los Angeles, was occasioned by the violation by these defendants of the antitrust laws, in that they were alleged to have entered into a combination and conspiracy to monopolize and unreasonably restrain trade and commerce in the distribution and exhibition of motion pictures in Los Angeles and in particular in the Westchester area of Los Angeles, which combination and conspiracy injured the Paradise Theatre and caused the Paradise to lose in excess of \$38,000.00 in the period of a single year and by causing the Paradise Theatre to lose profits which, in the absence of the conspiracy, it would otherwise have earned [R. 34-37]. The jury returned a verdict against Fox West Coast, Loew's and 20th-Fox in the amount of \$20,000.00, which amount was some \$18,000.00 less than the total loss by the Paradise in its first year of operation. In accordance with Section 4 of the Clayton Act (15 U. S. C. 15), the court trebled the damages awarded, entered judgment for appellee's attorney's fees and costs<sup>1</sup> [R. 153].

Appellants' motions for a directed verdict and motions for judgment, notwithstanding the verdict, were denied [R. 169]. Each of the appellants made a motion for a new trial, which were denied [R. 175]. In denying the motions for judgment notwithstanding the verdict, and in denying the motions for new trial, the trial court held

---

<sup>1</sup>The reduction and apportionment of attorneys fees and costs are the subject of a cross-appeal by appellee.

that the verdict was consistent with the evidence, should not be set aside and that no new trial should be granted [R. 157, 173].

Appellants then filed this appeal. In their statement of Points on Appeal, appellants attacked the judgment wholesale. They alleged not only that there was no substantial evidence to sustain it but, in general terms, that many errors were made in connection with admission of evidence and in connection with instructions to the jury [R. 2879]. In the specifications of error contained in appellants' opening brief, appellants have abandoned all of the points alleged in their Statement of Points on Appeal except that they assert that the verdict of the jury is not supported by substantial evidence and that the trial court erred in a single particular with respect to certain jury instructions.

The questions presented therefore are (1) whether there was substantial evidence in the entire record considered as a whole, giving to all the evidence the reasonable inferences most favorable to appellee, to sustain the jury's verdict based upon a special finding that "defendants, Fox West Coast, Loew's and 20th-Fox had engaged in a conspiracy with each other to monopolize and unreasonably restrain interstate commerce in the licensing of motion pictures to plaintiff for exhibition in the Inglewood-Westchester area on a 7-day run during the period from September 18, 1950, to September 17, 1951," and that appellee was injured thereby.<sup>2</sup> (*Gunning v.*

---

<sup>2</sup>A special interrogatory went to the jury which included the names of all of the defendants, *i. e.*, Universal, Paramount, Warner Bros., National Theatres Corp., Fox West Coast, Loew's and 20th-Fox [R. 2801]. The jury struck the names of all defendants other than Fox West Coast, Loew's and 20th-Fox [R. 2846]. Its verdict was to the same effect [R. 2849]. The jury also answered in the negative special interrogatory No. 1 as to whether any of the defendants had engaged in a conspiracy with each other to monopolize or unreasonably restrain interstate commerce in the licensing of motion pictures for exhibition on Los Angeles first run [R. 2845].

*Cooley*, 281 U. S. 90, 94, 50 S. Ct. 231, 234, 74 L. Ed. 720.) (2) Whether, in light of the jury's specific finding that appellants, Fox West Coast, Loew's and 20th-Fox, had participated in the conspiracy alleged, there was prejudicial error in the modification of defendant's proposed instructions 26, 21-A, 34, 31 and 11 by the addition of the words, "in the absence of a conspiracy."

### ARGUMENT.

The appeal, with the exception of the alleged error as to certain instructions, is an appeal from a jury decision on a question of fact. There were some 17 witnesses called to testify at the trial, which lasted approximately 7 weeks, and over 300 documentary exhibits were introduced by both sides. The transcript covers some 2883 pages. Necessarily, however, in an appeal based upon the contention that verdict is not supported by substantial evidence the parties are compelled to describe the evidence in the record. With this in mind, we offer our apologies in advance for the unavoidably lengthy summary of the testimony of the witnesses and the documentary evidence in the case as it was tried below.

#### I.

#### Background of the Conspiracy.

Appellee, Paradise Theatre Building Corp., was organized in 1949. It was a family corporation in which Alex Schreiber, his wife, and his son, Max Schreiber, were sole stockholders. The corporation was organized for the purpose of owning and operating a theatre in the Westchester area in the City of Los Angeles. The outlines of that area are in appellant's Exhibit X attached to their brief. The Schreiber family invested in excess of \$350,000.00 for the land, building and equipment of the Paradise Theatre [R. 1069-1070].

At the time the Paradise was constructed in the center of the Westchester district, its only immediate competitor

was the Loyola Theatre, owned and operated by appellant, Fox West Coast. The facts surrounding the construction of the Loyola Theatre and the period immediately prior thereto were described at the trial by the witness, Marco Wolff [R. 1480].

**A. Fox West Coast Excluded Competitors from Westchester.**

The witness, Marco Wolff, testified that in 1944 or 1945 he had a conversation with Charles P. Skouras, president of Fox West Coast, concerning the erection of a theatre in the Westchester district [R. 1480-1488]. The district was "a little undeveloped" [R. 1482] at the time, but later was to become one of the primary theatre revenue districts in the City of Los Angeles. Wolff tried to interest Skouras in going into a theatre in the Westchester district with him because at that time Wolff and Fox West Coast were partners in the Fifth Avenue and Alto theatres on the east side of Inglewood.<sup>3</sup>

---

<sup>3</sup>The partnership was the subject of a lawsuit in which Fox West Coast contended that the partnership agreement pertaining to the Fifth Avenue Theatre and the Alto Theatre violated the antitrust laws and was subject to divestiture pursuant to the decrees in *United States v. Paramount, et al.*, and should be dissolved. (*United West Coast Theaters Corp. v. Southside Inc.*, 178 F. 2d 648.) In this court, two of the appellants, Fox West Coast and 20th-Fox, represented by their same counsel as represent them in this case, asserted that the joint venture agreement pertaining to the Fifth Avenue Theatre was an illegal pool by reason of the decision in *United States v. Paramount, et al.*, 70 Fed. Supp. 53, 67. There the special three-judge expediting court held that certain operating agreements between the major theatre circuits (including National and Fox West Coast) and independent exhibitors were unlawful because "the effect is to ally two or more theatres of different ownership into a coalition for the nullification of competition between them and for their more effective competition of theatres not members of the pool." (70 Fed. Supp. 53, 67.) United West Coast Theatres Corp., one of the formal parties plaintiff in that case, also controlled substantially all of the other theatres in Inglewood, including Academy, United Artists, Inglewood and Fox Inglewood. Inglewood was clearly a monopoly town created by illegal ventures.



Skouras informed Wolff, on behalf of Fox West Coast, that they were not interested in the Westchester district for a theatre location at that time and told Wolff that he should not go into that district [R. 1482]. Skouras told Wolff that he objected to his "invading that territory" [R. 1486] just as he had previously objected to Wolff's invading the territory in which the Fifth Avenue Theatre had been built, which had been "resolved" by a partnership [R. 1486].<sup>4</sup> Wolff asked Skouras if he would permit him to go into the Westchester district by himself and Skouras objected to it [R. 1483].<sup>5</sup> Shortly after Skouras, the Fox West Coast president, had prevented Wolff from invading the Westchester territory by erecting a theatre, Fox West Coast itself acquired the land on which, in 1946, it opened the Loyola Theatre. The trial court rejected appellee's Exhibit 33-B, marked for identification and transmitted to this court, with respect to the acquisition of the Loyola property by Fox West Coast, which would have shown that in acquiring the Loyola site Fox West Coast obtained from the seller, who at that time controlled substantially all of the undeveloped property in Westchester, a written agreement that the seller would not sell any land which it owned for use as a theatre for a period of 5 years or until 7000 units were constructed in the Westchester area. This exhibit established that the intended effect of the agreement was to exclude the possibility of any outside theatre owner from constructing a theatre in Westchester. Appellee was

---

<sup>4</sup>This was the partnership between the Fifth Avenue and the Alto Theatres. (*United West Coast Theatres v. Southside Inc.*, 178 F. 2d 648.)

<sup>5</sup>Wolff testified that in those days and in subsequent days it was not considered good business to go into opposition with the big circuits without their permission. The witness, in answer to the court's questions, testified that this conversation was "friendly" in the sense of personal relationships, but certainly not with respect to business relationships [R. 1508].

directly affected by this restriction because when it acquired the Paradise property in 1947, it was thereby precluded from constructing a theatre until 1950 [R. 99-101; Pltf. Ex. 33(a) for identification].

Having thus excluded and prevented all competition from Westchester for five years, Fox West Coast then carved out this district as its own. The Fox West Coast Loyola Theatre was constructed in 1946 [R. 376]. Opened in October, 1946, the operating policy from the day it opened was an availability of Los Angeles first run in Westchester, exhibiting simultaneously on "day and date" with other first run theatres in Los Angeles [R. 377]. Los Angeles first run availability was the privilege of exhibiting feature motion pictures on the date of their first exhibition in the entire Los Angeles area simultaneously with other theatres. The Loyola policy of simultaneous first run exhibition in which it had equal "availability" with all of the other first run theatres in the City of Los Angeles and on which it played "*day and date*" or simultaneously with such other theatres was part of a policy which had been long established in Los Angeles.

#### **B. Day and Date Exhibition in the Los Angeles Area.**

In the Los Angeles area it had long been established that motion pictures should be exhibited simultaneously in groups of theatres. A study showing the exhibition of every motion picture distributed by the 8 major companies during the years from 1945 through 1951, covering at least 1500 pictures, showed overwhelmingly that day and date exhibition was the rule [R. 217-219; 749-756; 757-769; 796-802; Pltf. Exs. 46(A-4) to 46(A-17) and 54]. This "day and date" exhibition was the policy not only on first run but on the 7 day run, which commences 7 days after conclusion of the Los Angeles first run; on the 14 day run, which is a run commencing 14

days after the conclusion of Los Angeles first run; and on the 21 day run, which is a run which commences approximately 21 days after the conclusion of Los Angeles first run [R. 220, 536].

Simultaneous exhibition in Los Angeles was consistent with the recognition of the wide dispersion of the Los Angeles population, of the commercially recognized fact of convenience to patrons who thus would not have to travel long distances to early run theatres, of good business judgment for distributors who could take advantage of the first run advertising to get patrons into first run in higher admission theatres and to early 7 day run theatres for the same purpose, and was to the advantage of the exhibitors who were able to play motion pictures at a time when the advertising and exploitation were in the forefront of the public mind [R. 1928-1931]. The Loyola theatre played literally hundreds of pictures day and date or simultaneously with other first run theatres [Pltf. Exs. 46A-6 and 46A-14].

On the 7 day run in the Los Angeles Metropolitan area, there were many Fox West Coast theatres located throughout the metropolitan area, in such areas as Belvedere Gardens, Inglewood, Glendale, Pasadena, Westwood, Wilmington, which exhibited simultaneously on the 7 day run. In Inglewood, the Fox West Coast Academy (4.5 miles from the Paradise), the Fox West Coast Fifth Avenue (4.8 miles from Paradise), and Fox (2.9 miles from the Paradise) operated on the 7 day run and Marco Wolff's Southside (6.9 miles from the Paradise) exhibited many pictures day and date with these theatres on the 7 day run [R. 1506, 2480]. The La Tijera (2 miles from the Paradise) and Imperial (5.2 miles from the Paradise) also exhibited many pictures simultaneously with each other on the 7 day run [R. 879; 2521-2522].

### C. Patronage Potential in Westchester for Early Runs.

The theatre patronage potential of Westchester for early runs was graphically shown by the evidence that the Loyola Theatre in the Westchester district was one of the most successful theatre operations in the entire Fox West Coast Theatre Chain. This was the statement of Joseph Schenck, an executive of the 20th Century Fox, in charge of its studios, and a theatre partner of Fox West Coast in approximately 55 theatres throughout the State of California and in Inglewood [R. 1092]. The evidence showed that the Loyola, operating on Los Angeles first run availability in Westchester, was at the same time a neighborhood theatre [R. 218-219]. Its tremendous patronage was drawn substantially from within a four-mile radius [R. 1959]. Westchester was a special, highly successful theatre patronage area for early runs. The evidence showed that the Loyola Theatre in Westchester, exhibiting the same motion pictures on the same days as the Fox West Coast Uptown Theatre [Pltf. Exs. 46A-6, 46A-14], located at the nexus of the downtown and Wilshire District, had grossed more than that theatre continuously [R. 256, 257; Pltf. Exs. 79, 84], despite the fact that the Uptown had a larger seating capacity than the Loyola [Pltf. Exs. 79, 84]. The Loyola in Westchester was superior in its grossing potential to over half of the other Fox West Coast theatres, whether located on Hollywood Blvd., Wilshire Blvd., or in other first run districts [R. 255-257; Pltf. Exs. 79-84]. This theatre regularly returned more theatre profit to Fox West Coast than did the Grauman Chinese Theatre, a so-called world famous theatre on Hollywood Blvd. [R. 2547-2548; Pltf. Exs. 79, 80]. Annually, theatre profits from the Loyola ranged from approximately \$86,000.00 to \$142,000.00 [R. 2547].

It was significant that Fox West Coast chose Westchester to exhibit first run pictures, particularly those of

its parent corporation, 20th-Fox, although Fox West Coast at the same time was operating theatres in Inglewood, Belvedere Gardens, Pasadena, Glendale, Santa Monica, Ocean Park, Redondo Beach, in which it did not choose to play such first run pictures.

The evidence established that the potential of the Westchester area from early run from a theatre point of view was supported by (1) the fact that the area had only one and, after the Paradise was built, then only 2 theatres in central Westchester surrounded by a theatre-going public of 40,000 within an area of two miles [R. 1820]; and (2) the fact that these theatres were contemporary, comfortable modern theatres.

In contrast, the Inglewood area, an older suburban development, prior to 1949 had six established theatres. While, in 1950, within a two mile radius of the Fox West Coast Academy Theatre there were 102,000 people [R. 1821], there were also 7 theatres to share that population (see Appellant's Ex. X attached to Appellant's Brief.)

The evidence showed that the Loyola policy in Westchester was to exhibit on a simultaneous Los Angeles first run in Westchester. It exhibited, however, almost exclusively 20th-Fox pictures, although at one time or another the pictures of every distributor were exhibited in the Loyola on Los Angeles first run availability [Pltf. Ex. 53]. However, there was no theatre in Westchester exhibiting the pictures of Loew's, Universal, Warner Bros., Paramount, Columbia, United Artists, RKO, etc., on Los Angeles first run when the land for the Paradise theatre was acquired or when the theatre opened its doors. None of these distributors had first run outlets in West-



chester. Moreover, not a single distributor's pictures were being exhibited on a 7-day run in the heart of Westchester. Thus, this patronage pool on the 7 day run was untapped.

**D. The Paradise Was Excellently Suited for  
First Run or Seven-day Run Operation.**

It was established that the type of construction, the equipment and the furnishings of the Paradise Theatre were all designed with the express intention early run operation [R. 1065]. It was established that the timeliness of exhibiting motion pictures in a theatre such as the Paradise during the period 1950-1951 was of crucial importance to the success of theatre operation. This was true because in the distribution of motion pictures the impact of first run advertising wears off quickly, and as pictures left their first run exhibition, advertising and exploitation turned to new pictures and not to older ones. Thus while the advertising expended on the first run was many thousands of dollars [R. 417-418], advertising on the second run is contained in the small box advertising of theatre guides in newspapers [R. 1687-1688]. Therefore, the ability to obtain early run pictures was vital to the success of the Paradise.

Moreover, its major competitor, the Loyola, had established itself as a first run theatre in the area. The pictures being exhibited at that theatre were top quality pictures. The only way in which the Paradise could be successful would be to obtain the same quality of pictures regularly on the 7 day availability when the pictures were fresh and new.

II.

There Was Substantial Evidence of a Conspiracy Among Appellants to Unreasonably Restrain and Monopolize Trade in Licensing Motion Pictures to Appellee on the Seven-day Availability in Westchester.

As the Proximate Result of That Conspiracy (1) Appellee Was Excluded From Obtaining Motion Pictures for Exhibition on a Seven-day Availability Day and Date With Inglewood; (2) Appellee Was Excluded From Obtaining Motion Pictures on a Seven-day Availability on Any Terms.

Appellee opened its theatre on August 23, 1950. However, as early as April, 1949, Joseph Schenck, an executive of 20th Century Fox and President of United Artists Theatre Circuit, and at that time a co-venturer with Fox West Coast, was discussing with appellee's president the possibility of putting Loew's pictures in the Paradise on Los Angeles first run on condition of the acquisition of a 70% interest.<sup>6</sup> In March and April, 1950, appellee made his first contact with appellants Loew's and 20th-Fox, and the other major distributors, in order to acquire pictures for the impending opening of the Paradise [R. 1122-1159]. The damage period in this case is from September 23, 1950, to September 22, 1951. Thus prior to a detailed consideration of the testimony as to the attempts of the Paradise to obtain motion pictures, it is material to consider the evidence as to the agreement and relationships between the appellants and others which began prior to the opening of the theatre and which existed throughout the damage period.

---

<sup>6</sup>See discussion of this occurrence page 21.

The president of appellant, Fox West Coast, testified that as of 1949 the Academy, Fox, United Artists and Inglewood Theatres, all located in Inglewood, were being operated by a corporation known as United West Coast Theatres Corporation. That corporation also owned the Fifth Avenue Theatre. United West Coast Theatres Corporation operated approximately 55 theatres throughout the State of California [R. 317]. The organization of that corporation had been accomplished by Fox West Coast Theatre Corporation, and United Artists Theatres, Inc., and United Artists Theatres of California, Ltd. [R. 317]. The signatories to the agreement were Charles P. Skouras and John B. Bertero for Fox West Coast Theatres Corporation, and Joseph M. Schenck for United Artists Theatres of California, Ltd. The agreement setting up the corporation was introduced into evidence as Plaintiff's Exhibit 31F.

The testimony of the witness, Bertero, and Exhibit 31F showed that in addition to the theatres in Inglewood United West Coast Theatres Corporation, in 1949, operated the Egyptian Theatre on Hollywood Boulevard; the Four Star, El Rey and Ritz on Wilshire Boulevard. In the suburban communities, that corporation operated 7 day run theatres in Pasadena, Glendale, Belvedere Gardens and it operated first run theatres in Long Beach, California [R. 317-322].

The corporation was owned in 1949, 70% by appellant, Fox West Coast, and 30% by United Artists Theatres of California, Ltd., a subsidiary of United Artists Theatre Circuit, Inc. [R. 316-317]. The president and controlling owner of United Artists Theatres of California, Ltd., and United Artists Theatres of California, Inc., was

Joseph M. Schenck, the brother of Nicholas Schenck, president of Loew's, Inc. This same Joseph Schenck was an executive of appellant 20th-Fox [R. 280, 1071]. Fox West Coast and United Artists Theatres Circuit, Inc., were required to terminate their joint interests in the United West Coast Theatres Corporation.<sup>7</sup>

From the Spring of 1948 to the end of 1949, appellant, Fox West Coast and UA Theatre Circuit, Inc., and Joseph M. Schenck, who had the dual role of executive of 20th-Fox and partner with appellant, Fox West Coast Theatres, were negotiating for the termination of their jointly owned theatre interests in United West Coast Theatres Corporation [R. 322-324; 344]. The termination involved the return to the various parties, subject to some adjustment, of the theatres which each of them had contributed to the pool, as set forth in Exhibit 31F.

The testimony of Bertero and Plaintiffs' Exhibit 31F, pages 34-43, shows that these theatres were located, in many cases, in the same city, so that ostensibly when United West Coast Theatres was dissolved they would be operated in competition with each other. A typical example was Inglewood, where United Artists Theatres had contributed the United Artists Theatre and it was returned to it, while the Academy, Fox and Inglewood were returned to Fox West Coast.

However, in anticipation of the termination of the joint interests and the imminence of "competition," the evidence showed the following agreements entered into

---

<sup>7</sup>Their joint interests were held to be unlawful in *United States v. Paramount, et al.*, 70 Fed. Supp. 53, 67.

between Fox West Coast, United Artists Theatre Circuit, Loew's, Inc., 20th-Fox and others:

- (a) Fox West Coast, Loew's and United Artists Theatres agreed that in non-bidding situations throughout the State of California, wherever Fox West Coast, and United Artists Theatres would have theatres that would normally be in competition with each other, Loew's product would be licensed to the United Artists Theatres and Fox West Coast would not compete for it [R. 626-638];
- (b) The parties would agree as to the allocation of all distributors' product [R. 637-638]. Thus, Bert Pirosh, the chief buyer for Fox West Coast, testified that in a meeting with a representative of UA Theatres, Pat DiCicco, DiCicco outlined each town and each theatre and certain distributors he wanted and Pirosh did the same. The distributors, where necessary, were contacted for approval [R. 638-639].

Thus, the evidence was clear that all the distributors were directly involved in the arrangement.

Specifically, with respect to Loew's, Pirosh testified that DiCicco had informed him he had discussed the matter with the Loew's sales manager, Hickey, and that Hickey was agreeable [R. 630-637]. In Inglewood, DiCicco had asked Pirosh not to bid against United Artists Theatres and Hickey of Loew's agreed to that arrangement [R. 601-604]. Pirosh testified that he checked with Hickey as to his conversation with DiCicco about Loew's product and Hickey was agreeable [R. 631-634; 636-637].

Corroboration of this arrangement between the parties, if such corroboration was necessary, was clearly dem-



onstrated by the testimony of Hickey, Loew's Pacific Coast Manager. He testified that he and Edwin Zabel, who was then the chief buyer for Fox West Coast, agreed to switch the Loew's product from three theatres in which Fox West Coast then had an interest, *i. e.*, the Egyptian,<sup>8</sup> Los Angeles and Wilshire, to the two other theatres which the United Artists would obtain an interest in, *i. e.*, the Egyptian and Loew's State [R. 405-410].

Further corroboration came from testimony by Alex Schreiber as to conversation with Joseph Schenck, the executive of 20th-Fox, and the head of UA Theatres. They had a meeting in March, 1949, when Loew's product was being exhibited in the Wilshire, Egyptian and Los Angeles theatres, and Schenck informed Schreiber then that Loew's product would be exhibited in the Egyptian and Loew's State [R. 1091]. The transfer as predicated took place in November, 1949.<sup>9</sup>

During the first so-called "bidding" period in Inglewood, commencing in September, 1949, Pirosh testified that he, on behalf of Fox West Coast, and DiCicco, on behalf of UA Theatres, agreed that Loew's product would go to the United Artists Theatres and they would not bid against each other for that product. Hickey was agreeable [R. 601-604]. In fact, during this so-called "bidding" period, each and every distributor, *i. e.*, Loew's, 20th-Fox, Paramount, Warners, Universal, Co-

---

<sup>8</sup>The termination of Fox West Coast interest in the Egyptian was as of January 1, 1950 [R. 323-324].

<sup>9</sup>Irving Epsteen, an employee of Fox West Coast, was put on the witness stand and was not even asked by appellant, Fox West Coast or 20th-Fox, to deny the testimony. The conversation with Schenck was established without contradiction [R. 2515-2518].

Columbia, RKO, United Artists, agreed to a complete allocation of the exhibition of pictures on 7 day run in the Inglewood area. The allocation was as follows:

<u>Distributor</u>	<u>Exhibitor</u>	<u>Availability<sup>10</sup></u>	<u>Record Cit.</u>
WARNER BROS.	La Tijera & Imperial	7 da-LA day and date	[R. 606-608; 616-617].
COLUMBIA	<i>Split</i> between La Tijera & Fox West Coast Academy	7 da-LA (a) La Tijera & Imperial day and date (b) Academy exclus.	[R. 2521-2522; Pltf. Ex. 46 A-9].
COLUMBIA	(a) La Tijera to Fox West Coast 5th Ave. (b) Fox West Coast Academy to Fox	Move-over  Move-over 7 da-LA day and date	[R. 2521-2522; Pltf. Ex. 46 A-9].
RKO	La Tijera- Imperial	7 da-LA day and date	[R. 607-608; 616-617].
UNIVERSAL	<i>Split</i> La Tijera-Fox West Coast Academy	7 da-LA (a) La Tijera & Imperial day and date (b) Academy exclus.	[R. 611-614, 622; Pltf. Ex. 51].
PARA- MOUNT	Academy	7 da-LA exclus.	[R. 609-610].
20TH-FOX	Academy	7 da-LA exclus.	[R. 609].
LOEW'S	United Artist	7 da-LA exclus.	[R. 601-604].

This arrangement arose out of the agreement with Fox West Coast and United Artists Theatres and La Tijera Theatre. Distributor participation in the arrangement, which is self-evident from the simple fact that it would be impossible to carry out the arrangement without their direct knowledge and participation, was testified to directly by the Fox West Coast manager, Pirosh. He tes-

<sup>10</sup>Abbreviations are "7 day-LA" for 7 days after Los Angeles first run closing; "Day & Date" for simultaneous exhibition in theatres named; "Exclus" for exclusive 7 day run; "move-over" means completing exhibition in one theatre and starting in another without any elapse of clearance time; "split" for division of pictures of a distributor between two exhibitors.

tified that there was a discussion with Loew's [R. 630]; that he talked with the sales managers of Warner Bros. and RKO [R. 624-626]. He first denied and then admitted discussions of the "split" with Universal [R. 611, 622]. The Columbia Branch Manager testified by stipulation as to conversations with Fox West Coast and the La Tijera [R. 2521-2522]. The Universal records themselves provided the reference that an agreed division of product had been arranged [Pltf. Ex. 51; R. 611-614, 869-875]. The jury was not only required, but compelled to come to the conclusion that this was a total arrangement between Fox West Coast, United Artist Theatres and the distributors in the area to allocate 7-day run pictures in the Inglewood area. Moreover, the record was clear that the distributors carried out this arrangement secretly by maintaining a facade of "bidding letters"; that is, even though each of these distributors *knew in advance* that a particular theatre was the theatre that would obtain the picture, it sent out offers to all theatres. Thus, Fox West Coast received bid letters from Columbia although the branch manager of Columbia testified that there was an agreement not to compete [R. 2521-2522]. The same was true as to Loew's. Each of the distributors sent out bid letters, although each of them knew that the allocation had been arranged.

As was set forth above, this arrangement commenced in September or October, 1949. Subsequently, Hickey, the Pacific Coast Manager of Loew's, admitted, under cross-examination, that as of 1950 and 1951 Fox West Coast and United Artist theatres and others agreed, throughout the State of California, *wherever there was bidding*, that the exhibition of motion pictures should be allocated between them [R. 543-553].

Hickey discussed these agreements with Pirosh, of Fox West Coast; Fred Stein, of United Artists Theatre Circuit, and Leo Miller, the buyer for Warner Bros. [R.

553]. He testified that records were kept in his office of the conversations because "when these men left his office notes were made of what they said" [R. 550]. He testified that "each and every one of these men" told him personally that they were conforming to these arrangements and that they not only did it in Los Angeles but did it all over the state, *wherever there was bidding* [R. 550]. His testimony was that the arrangement covered every picture and that these men had been in his office to discuss the arrangement not once but a dozen times [R. 551]. When it was not discussed in his own office, it was discussed on the telephone [R. 552].<sup>11</sup>

The Fox West Coast witness, Zabel, also testified as to the distributor participation in such arrangement at that time—1950-1951 [R. 257-263].

Pirosh, the Fox West Coast sales Manager, corroborated this arrangement. He testified that in Inglewood he discussed the bidding with the United Artists Theatre Circuit representative, Fred Stein [R. 649].<sup>12</sup>

The evidence was uncontroverted that on the 7-day run all of the 7-day areas were controlled by Fox West Coast. The Loew's witness, Hickey, testified that they were all Fox towns [R. 537]. This included Pasadena, Huntington Park, Glendale, East Los Angeles, Culver City, Westwood, Inglewood. In each of these areas, Fox West Coast and United Artists Theatres, or Fox West Coast and Warner Bros., together with the distributors, allocated 7-day run pictures. Thus, Pirosh testified that Warners had competing 7-day run theatres in Hunting-

---

<sup>11</sup>The date when these arrangements commenced was established as the date when "bidding" commenced on first run in June 1950 [R. 597-598].

<sup>12</sup>As to the discussion of the *amount* of each bid, Pirosh made the following statement: "I am *practically* positive that I did not ask Mr. Stein what he was going to bid on any of *his* pictures—any pictures." (Emphasis supplied.)

ton Park, San Pedro and Beverly Hills; that "customarily" Fox West Coast would play the product of certain distributors and Warners would play the product of other distributors [R. 641]. With respect to one distributor, RKO, the arrangement was that Fox West Coast would obtain 75% of the pictures and Warners 25% [R. 645-647]. The division was arrived at by agreement between him and Leo Miller, the Warner's representative. (Note: This same 75/25 division of RKO pictures on the 7-day availability applied to San Pedro and Beverly Hills [R. 645-647].)

The testimony by Hickey, hereinabove referred to, established the facts as to arrangements between Fox West Coast, Warner Bros., United Artist Theatres and the distributors when "bidding" commenced [R. 543-553].<sup>13</sup>

In those 7-day run situations such as Pasadena, Glendale and Inglewood, where Fox West Coast and United Artist Theatres Circuit were involved, the testimony by Hickey and the plain facts showed a conspiracy between the parties. There was direct testimony that Fox West Coast prevented any independent theatre from exhibiting simultaneously with any of its theatres in Los Angeles on first run. Thus, Zabel, the chief buyer of the entire National Theatre Circuit, testified that if Fox West Coast purchased a picture for a first run exhibition in downtown Los Angeles, no other theatre other than a Fox West Coast theatre was permitted to exhibit that picture at the same time [R. 278-279]. The record shows that the only other exception is that a United Artists theatre was, on occasion, permitted to play simultaneously [R. 255]. Thus, new first run areas were precluded by Fox West Coast.

---

<sup>13</sup>Bertero, president of appellant, Fox West Coast, and a lawyer, admitted that the arrangements, such as were testified to by Pirosh and Hickey were unlawful [R. 364-365].



Similarly, the evidence was that when the appellee opened the doors of its theatre and sought to license in Westchester a 7-day availability day and date with Inglewood, it was the Fox West Coast plan, adhered to by the distributors, which denied pictures on this 7-day availability to the Paradise.

**A. The Impact of the Conspiracy Upon the Paradise Theatre.**

Alex Schreiber testified that after he had acquired the land and had prepared the plans for the construction of the Paradise as an early run theatre in Westchester, Joseph Schenck, then chief executive of 20th Century-Fox Studios, and the head of United Artists Theatres Circuit, Inc., arranged for a meeting with Schreiber, Schreiber's son, Max, one Pat DiCicco, the executive in charge of United Artists Theatres, and Irving Epstein, an employee of Fox West Coast. At that meeting, Schenck confirmed Schreiber's knowledge that the Westchester area was an excellent area for an additional theatre; that the Fox West Coast Loyola Theatre, exhibiting primarily 20th Century pictures, was one of the best theatres in the entire Fox West Coast chain. Schenck said they would put Loew's product on the first run Los Angeles availability in the Paradise Theatre day and date with the Grauman's Egyptian and Loew's State downtown and that they wanted a 70% interest in the theatre<sup>14</sup> [R. 1070-1092].

Max Schreiber corroborated the testimony of his father. He testified that Schenck had told them that their worries about pictures would be over. Schenck said that it would be better for the Schreibers if the Schreibers had 40% with the Schenck group than 100% interest by themselves because the Schreibers "*would not have any pictures.*" Schenck further stated that *they had all the pictures and*

---

<sup>14</sup>Schenck's proposal through Epstein was 50%. It was raised to 60% and then to 70% [R. 1093].

*could do whatever they wanted* [R. 1671]. No witness was called by the defense to deny this testimony. Irving Epstein, at the time of the trial, was still employed by Fox West Coast. He was called to the witness stand, and was not examined by the defense concerning the matter. As was pointed out by the trial Court, this testimony was never questioned. According to the statement of the defense, the court said, "they have not questioned his (Schreiber's) testimony" [R. 2518].<sup>15</sup>

Schreiber testified that at some time after he began construction of the Paradise, he had a conversation with Charles Skouras, president of the appellant Fox West Coast, in the presence of witnesses [R. 1100]. Skouras asked Schreiber why he built the theatre in his (Skouras') territory and he told Schreiber he should not have come into his (Skouras') territory. When Schreiber replied that the Westchester area was a growing area; that it could support two theatres; that the Paradise was intended as a theatre which would be a credit to the motion picture industry and when he pointed out that the Loyola Theatre was doing excellent business and that there were more than enough people to serve the area, Skouras' reply was that Schreiber should not come into his territory [R. 1102].

At a time when the Paradise Theatre was ready to open but was unable to obtain any pictures to open its doors, Zabel, the chief film buyer for Fox West Coast, talked with Max Schreiber and later with Alex Schreiber about acquisition of the Paradise [R. 1669, 1110-1112]. At that time Marco Wolff had been employed to attempt to

---

<sup>15</sup>The proposed transaction was never concluded [R. 1098]. At the time that the agreements were to have been put in final form by the attorneys, Schenck and Charles P. Skouras were meeting in Florida to negotiate termination of the United West Coast Theatre matter [R. 1663]. After this meeting with Skouras, Schenck took no further steps to complete the deal with Schreiber.

obtain pictures for the Paradise. Zabel joined in the statement to Alex Schreiber that Wolff would never obtain 7-day availability pictures for the Paradise [R. 1112] but that if the acquisition was accomplished, that there would be no trouble in obtaining 7-day pictures for the Paradise [R. 1669]. Zabel was not called by appellants to controvert this testimony although he was in the courtroom and employed by Fox West Coast [R. 189].

At a subsequent conversation with Skouras, in the presence of his general manager, George Bowser, Skouras (1) attempted to purchase the Paradise on condition that "the price must be cheap" [R. 1105] and repeated the statements that had been made to Schreiber by the 20th-Fox executive and Fox West Coast partner, Schenck [R. 1671], and by the chief film buyer of Fox West Coast, Zabel [R. 1112], that the Paradise *would not get pictures*. Appellants did not call Bowser to controvert this testimony.

This evidence that Schreiber had built his Paradise Theatre in territory that "belonged" to Fox West Coast and that as long as he retained the theatre he would not be able to obtain early run pictures was borne out by the facts.

During the period from February, 1950 to August 23, 1951, the Paradise Theatre was represented in negotiations with appellants Loew's and 20th Century and the other distributors of motion pictures by four different individuals. The first was appellee's president, Alex Schreiber; the second was an attorney from the City of Chicago, Ill., Seymour Simon; the third was an exhibitor with some 40 years of experience in the motion picture industry, Marco Wolff (the same Marco Wolff who had been prevented from building the theatre in the Westchester District by Charles Skouras in 1944); the fourth individual, representing the Paradise, was Sid Lehman, an operator of an independent buying organization.

From February, 1950, through August 23, 1950, appellee's president, alone, and sometimes with his son, Max Schreiber, or with his attorney, Seymour Simon, sought from Loew's and 20th Century-Fox and from Universal, Warners, Paramount, Columbia, RKO and United Artists the privilege of licensing motion pictures on a non-exclusive first run in the Westchester area. Each of these distributors flatly refused to negotiate on any terms for such a run for the Paradise Theatre [R. 1114-1173], and the Paradise Theatre, during the period August 23, 1950 to September 22, 1951, never exhibited a single motion picture on Los Angeles first run availability. The same request was made by Marco Wolff and by Lehman. All of these requests were uniformly rejected.

During the period of at least three months prior to the opening of the Paradise Theatre on August 23, 1950, Schreiber requested the opportunity to negotiate for a non-exclusive 7 day availability in the Paradise Theatre in Westchester, the same availability that was then being licensed to theatres of Fox West Coast and the United Artists Theatre Circuit and Warner Bros. theatres throughout the Metropolitan Los Angeles area. The same request was made by Marco Wolff to Loew's, 20th Century-Fox and to all other distributors [R. 1507]. The same request was made to all of the distributors by Lehman [Pltf. Ex. 7H]. Loew's, 20th Century, Universal, Warners and Paramount refused this request. RKO and Columbia likewise refused until approximately March of 1951, and United Artists until 1951. Thus, during the period from August 23, 1950 to September, 1951, the Paradise exhibited the following 7-day run pictures: Loew's 0; 20th Century-Fox 0; Universal 0; Paramount 1; Warners 3.

**B. The Reason for the Refusal.**

Marco Wolff, who negotiated with the distributors prior to the opening of the Paradise Theatre, testified that all of the distributors, including Loew's and 20th-Fox, refused the request of the Paradise to exhibit on a non-exclusive 7-day availability in Westchester because Fox West Coast refused to permit it and insisted on clearance over the Paradise [R. 1507].

The testimony by Wolff that the distributors refused to permit the Paradise to have an equal availability of 7 days after Los Angeles first run closing which Fox West Coast had for many of its theatres throughout the Los Angeles Metropolitan area because Fox West Coast insisted on clearance on behalf of the Academy over the Paradise, was corroborated by the witness Lehman, who took over the buying for the Paradise Theatre in January, 1951. Thus, Lehman testified concerning four written requests that he had sent to Universal to exhibit pictures on 7-day availability non-exclusive without clearance over any other theatre [R. 1563-1568; Pltf. Exs. 15, M, O, P, Q-1]. The last letter had to do with the Universal picture "Up Front." Lehman testified that he talked to Marriott, the Universal branch manager, who told him that the Universal picture "Up Front" would exhibit in the Academy Theatre in Inglewood on the 7-day availability. Lehman asked Marriott if the Paradise could play the picture day and date with the Paradise.

Marriott said that if Lehman could obtain permission from Fox West Coast, it would be satisfactory to him [R. 1567]. Lehman called Frank Prince, an assistant to Bert Pirosh, and told him that Universal was agreeable to playing the picture day and date with the Academy and requested Fox West Coast permission to play the picture day and date. Prince refused [R. 1567-1568].



Lehman testified that Cohen, branch manager at RKO, told him that on pictures that were purchased by the Fox West Coast Academy, Fox West Coast would not permit the Paradise to play on the 7-day availability simultaneously [R. 1583].

When a Columbia picture was licensed to the Fox West Coast Fifth Avenue Theatre and the Paradise was permitted by Columbia on *that* picture to exhibit simultaneously, Fox West Coast removed the picture from the Fifth Avenue program because the Paradise had been permitted to exhibit simultaneously [R. 1586-1587, 1613].

Marriott, the Universal branch manager, testified that Fox West Coast insisted on clearance over the Paradise [R. 1888; Pltf. Ex. 14k]. Marriott testified that Fox West Coast categorically refused to permit the Paradise to play day and date with the Academy. He testified that it was Fox West Coast that determined whether or not the Paradise would be permitted to play on a 7-day availability, whether or not it received the picture [R. 944]. Because of the pressure of Fox West Coast, Universal would never permit the Paradise to play day and date with the Academy [R. 943-945]. Marriott testified that Fox West Coast took the position that under no circumstances would they permit the Paradise to play day and date with their theatres [R. 949].

The Fox West Coast sales official, Bert Pirosh, testified he insisted on clearance over the Paradise Theatre [R. 707, 839, 843].

By reason of the position taken by Fox West Coast, each of the film companies executed agreements with Fox West Coast whereby clearance was granted over the Paradise Theatre [R. 457]. Thus, as a result of Fox West Coast action and adherence by Loew's and 20th Century-Fox and the other distributors, the Paradise was refused the opportunity to license motion pictures

on a non-exclusive 7-day availability in Westchester, and Fox West Coast, Loew's, 20th-Fox and other distributors entered into agreements whereby they bound themselves not to permit the Paradise Theatre to exhibit those motion pictures until a period of time after the conclusion of the 7-day run exhibition in Inglewood. Schreiber testified that as a result of these arrangements the Paradise was forced to operate for the 52-week damage period with pictures that had been exhibited in prior years, or with late availability pictures. On the rare occasion that the Paradise obtained a 7-day run picture from non-defendants Columbia and RKO, who generally produced inferior pictures, the Paradise, because it had no other pictures available, was required to play at least one-half of its program with late availability pictures. Moreover, the Paradise was compelled to hold over top features on second weeks and to bring in older pictures as a second feature, thus eliminating a great segment of its potential patronage [R. 1399-1403]. There was no contradiction of the testimony to the effect that the policy upon which the Paradise operated was damaging to its theatre and caused the loss that it suffered in the amount of approximately \$38,000.00.

**C. There Was Substantial Evidence That Pursuant to the Conspiracy, Appellant Imposed Upon the Paradise (a) Unreasonable Clearance and (b) the Unreasonable Requirement of So-called "Bidding" Against Non-competitive Theatres in Inglewood.**

The jury was entitled to conclude that the refusal to license equal availability to the Paradise and the granting of clearance over the Paradise because of the position of Fox West Coast was unreasonable. Evidence was introduced which showed that Loew's refused to permit the Paradise to exhibit on a simultaneous 7-day availability in Westchester, even before the first picture was exhibited

in that theatre. In April, 1950, 20th-Fox refused to license any pictures [Pltf. Ex. 18C] and again before the theatre was opened. Universal, Warners, Paramount and Columbia all took the same position and all prior to the opening of the theatre. As of that date, of course, since the Paradise had not opened its doors and had not exhibited a single picture, Loew's and 20th-Fox had no knowledge whatsoever as to any of the factors which would permit them to make a reasonable decision. They refused to negotiate the terms for a single picture. In so far as 20th-Fox had any knowledge from the distribution of pictures in the Loyola Theatre, it was evident, of course, that the Paradise could pay tremendous film rental. The other distributors, including Loew's, if they knew about the Loyola operation, would have the same information, but in any event none of them ever requested the Paradise to negotiate any terms for a non-exclusive 7-day availability in Westchester.

As has been pointed out above, Fox West Coast insisted on clearance over the Paradise and the grounds stated by Fox West Coast were that the Paradise and Inglewood Theatres were in substantial competition. Loew's and 20th-Fox took the same position. But as of August 22, 1950, again none of these corporations had any knowledge as to whether the exhibition of a simultaneous 7-day availability in the Paradise would affect any theatre in Inglewood in any way. The Paradise had not opened its doors but each appellant took the position that the Paradise and Inglewood Theatres were in substantial competition. Moreover, evidence was introduced to show that each of the distributors was specifically requested to try out the Paradise by licensing the Paradise simultaneously with some theatre in Inglewood and thus to determine by actual facts whether there was any competition between the two. Each distributor refused [Pltf. Ex. 6m].

D. The Evidence That the Paradise and Inglewood Theatres Were Not in Substantial Competition.

*Testimony of Alex Schreiber.* Schreiber testified that from a theatre economics point of view, Westchester and Inglewood were separate areas; each had its own shopping centers; and each was self-sufficient to a considerable extent from a commercial point of view. The Paradise was separated from all of Inglewood by a railroad track and in addition was separated from the Academy and Fifth Avenue Theatres by a race track and a cemetery [R. 1181-1189].

Schreiber testified that Warners, Universal, Paramount, 20th Century-Fox, all permitted the Academy Theatre to exhibit pictures simultaneously with the Southside Theatre. Loew's did not grant clearance of the Academy Theatre over the Southside. The distance between the Academy and Southside Theatres was stipulated to be  $3\frac{1}{2}$  miles while the Paradise was  $4\frac{1}{2}$  miles from the Academy.

*Testimony of Marco Wolff.* Marco Wolff testified that in his opinion the Paradise was not in substantial competition with any of the theatres in Inglewood, or with the La Tijera. He was the operator of the Southside Theatre and he testified that it was proven that the Southside,  $3\frac{1}{2}$  miles from the Academy, could be a successful theatre playing most of its pictures simultaneously with the Academy Theatre [R. 1506].

Wolff testified that Fox West Coast wanted clearance at the Academy over the Paradise, but did not ask for clearance over the Southside [R. 1507] although the Paradise was farther from the Academy than the Southside. Wolff testified under the court's questioning that the distributors *would not* sell pictures for Paradise where they *would* at the Southside because the Fox Theatres in Inglewood had demanded clearance over the Paradise [R. 1509].

Wolff testified that the Westchester area as of the date of his testimony was a larger area than the Southside area and as of 1950-51 "pretty well developed" [R. 1515].

In that area, Wolff testified that all of the film companies had always played more than 7-day runs in Inglewood. Wolff testified that the Cemetery is between Inglewood and Academy and Fifth Avenue [R. 1527] and a large undeveloped area between downtown Inglewood and the Paradise [R. 1527]; that by adding a run with the United Artists Theatre in Inglewood the drawing area of the two theatres would be increased by approximately 50-75% and that this would multiply the film rental by anywhere from  $2\frac{1}{2}$  to 3 times. Thus, as an example, if a theatre operator on an exclusive run would gross \$4,000.00, with three runs, the gross on those three runs, playing day and date, would be \$10,000.00, or on a separate picture, \$12,000.00. Wolff testified that by adding day and date runs you increase the drawing area and the patronage is only cut up in a very small degree, and he testified to those facts on that basis of his own experience [R. 1542]. He pointed out that the experience on the exhibition of the motion picture "Born Yesterday" at the Southside, La Tijera, Paradise and Imperial clearly demonstrated that the four theatres could play simultaneously and do well. He testified that his experience at the Southside on that picture supported his conclusion [R. 1542-1543].

*Testimony of Syd Lehman.* Syd Lehman, the buyer and booker for the Paradise from January, 1950 to August, 1951, who bought and booked for approximately 55 theatres, testified that in his opinion the Paradise was not in substantial competition with the downtown Inglewood theatres, the Academy or the La Tijera or the Southside. The basis of his opinion was that the Paradise had a separate shopping center; that it was a complete



and distinct area unto itself and would not draw any substantial business from any other area. Moreover, he testified that in highly populated areas, such as those in which these theatres were located, the distances between these theatres made it clear that there was no substantial competition. This is because in highly populated areas the area of competition narrows considerably [R. 1592-1593]. Lehman emphasized the fact that the distributors clearly recognized that there was no substantial competition where theatres were located  $3\frac{1}{2}$  miles from each other when they played the Southside and the Academy simultaneously. It was thus clear that the Paradise, which was located  $4\frac{1}{2}$  miles from the Academy, was not in substantial competition with that theatre [R. 1592].

His experience with the picture "Samson and Delilah," which played day and date in the Paradise and other theatres, demonstrated to him that the Paradise was not in substantial competition with the other theatres.

*Testimony of Bryan D. Stoner.* The witness Bryan D. Stoner testified that he had been employed for many years by appellant Loew's and from 1945 through 1954 by 20th Century-Fox. Since 1954, he had been employed by Paramount. During the period from 1948 through 1951 he was assistant Western Division Sales Manager with direct responsibility over Los Angeles [R. 2450]. He testified that he had complete familiarity with Westchester and Inglewood.

It was stipulated that the Paradise, exhibiting on a 7-day run in Westchester, would not be in substantial competition with the Loyola [R. 1574].

Stoner testified that there were many pictures that played day and date between the Academy and the Southside or between the Academy and other Fox Theatres in Inglewood [R. 2480].

As to the effect on 20th Century-Fox of exhibiting simultaneously with the Southside Theatre, 3½ miles from the Academy, Stoner testified as follows:

“Q. If the Academy was playing alone, and then it played day and date with the Southside, would the Southside have taken away 30 per cent of the business of the Academy? A. As I recall, our grosses in Inglewood did not seem to depreciate at all when we began to play day and date in the Southside Theatre, which could lead me to believe they were drawing from a different area completely.

Q. In other words, when the Academy was playing alone, and then you played the Southside day and date, you recall that your grosses in the Academy were not affected to any marked degree? A. I couldn't pinpoint the Academy Theatre, as I recall it, but in making our studies after we began the experimentation, our revenue was not affected or depleted due to the fact that we had played the Southside Theatre day and date with some theatre in Inglewood.

Q. Your revenue was not depleted due to playing day and date with some theatre in Inglewood, that is correct? A. To the best of my recollection. It was enhanced, as a matter of fact [R. 3258].

Q. It was enhanced? A. Increased.

Q. Increased. The revenue of the Academy Theatre increased? A. Our revenue from the area.

Q. The revenue from the area was increased when the Southside Theatre was permitted to play day and date? A. To the best of my recollection, yes.” [R. 2488-2489.]

Greenberg, the District Manager for Warners, testified the Southside Theatre was not strongly or seriously in competition with downtown Inglewood [R. 2068, 2070].

Greenberg testified that as far as Warners was concerned they would have served day and date between the Paradise and the La Tijera [R. 2126-2127].

There was testimony by Zabel of Fox West Coast, Pirosh of Fox West Coast, Schreiber, Wolff and Lehman that the area of competition is sharply less on a 7-day run than on first run. An expert market analyst, called by defendants, testified that from a survey of the drawing area of the Loyola Theatre, taken in 1951, the overwhelming source of the patronage was within a radius of 4 miles of the Loyola. This was true because it was conceded the Loyola Theatre was, at the same time, a first run and neighborhood theatre [R. 1957-1960]. Since the drawing area for the Loyola was 4 miles on first run and the inference was clear that the second run—the 7-day run—would have a far more restricted drawing area. In fact, the same witness testified that the drawing area of an Inglewood 14-day run theatre was 2 miles [R. 1961].

Other evidence corroborated the fact that in Westchester, as in Inglewood, which areas were both essentially neighborhood theatre areas, the drawing areas of theatres on 7-day run were substantially less than 2 miles. Thus, the evidence showed that the La Tijera and United Artists Theatres, located only 1.9 miles from each other, exhibited pictures on the 7-day run simultaneously with each other [R. 2060-2063]. On occasion, Fox West Coast moved over a picture from its exhibition on the 7-day availability in the Academy to the Fox Theatre in downtown Inglewood located only 2 miles away. Moreover, as was pointed out by Alex Schreiber, in all his letters of August, 1950, the Inglewood theatres on Fox pictures followed the Loyola 4 miles away, and both groups of theatres were tremendously successful.

Testimony was introduced that Columbia permitted the Paradise to play simultaneously with the La Tijera,

the Imperial and the Southside. The La Tijera was less than 2 miles away. On the picture "Born Yesterday" the Paradise, playing simultaneously with the Academy, grossed more than it had on any other picture, thus indicating that playing simultaneously with the La Tijera had no material effect upon the Paradise gross [Pltf. Ex. 45J].

It is clear from this testimony that the jury was entitled to conclude that:

(a) There was no substantial competition between the Paradise and the Inglewood Theatres or the La Tijera; and

(b) That therefore clearance of these theatres over the Paradise was unreasonable; and

(c) That the refusal to license a day and date run was therefore part of the conspiracy between Loew's, Fox West Coast, 20th Century, United Artists and United Artists Theatre Circuit to prevent the Paradise from obtaining 7-day run pictures on equal availability with the theatres in Inglewood;

(d) That requiring the Paradise to bid for the Inglewood 7-day availability against the 7 theatres in Inglewood was arbitrary and unreasonable.

As has been pointed out, 20th Century refused to negotiate with the Paradise for 7-day availability with the Paradise in Westchester on any terms [R. 1578]. Loew's although the evidence showed that the Paradise was not in substantial competition with Inglewood Theatres, would refuse to serve the Paradise unless they would enter into what Loew's termed "competitive bidding" for the Inglewood run [R. 1129 and 1569]. It will be recalled that Hickey, the Loew's witness, testified that at this very time that bidding was being required, he knew that United Artists Theatres and Fox West Coast had agreed to allocate pictures throughout the State of California

[R. 543-553]. Bidding had been carried on from September, 1949 to May, 1950 when Loew's knew that the pictures were to be allocated to United Artists Theatre Circuit. It was apparent that the jury believed and could not have believed anything other than that the bidding request was a sham.

As an example, as has been pointed out above, Loew's insisted on the Paradise bidding for the Inglewood run even before it knew any facts concerning competition between the Paradise and Inglewood theatres [R. 558]. Moreover, the evidence showed that when Marco Wolff submitted bids, Loew's turned down the bid request without any knowledge as to what the gross potential of the Paradise was. Loew's refused to license a single picture to the Paradise in order to determine what the gross potential of the Paradise was on 7-day availability [R. 558]; in the actual execution of the so-called bidding it was clear that Loew's was carrying out the conspiracy. Thus, on a group of pictures as to which Loew's refused to negotiate for a 7-day availability even on pictures which were not sold on bidding but pursuant to "negotiation" [R. 489, 495, 496].

The Fox West Coast handling of this bidding arrangement was clearly demonstrated by the testimony of Greenberg and Marriott. Thus in those situations where Fox West Coast won a bid which would give clearance of Fox another Southside, Fox used the mechanics of waiver of clearance to determine what theatres would play on a simultaneous 7-day availability. Marriott of Universal testified that it was Fox West Coast that determined who would play the 7-day availability; whether or not they purchased the picture [R. 949].

The jury was thus entitled to believe that it was arbitrary and unreasonable:

(a) To refuse a day and date 7-day run to the Paradise; and



(b) to require bidding between the Paradise and non-competitive theatres.

Obviously, the only function of competitive bidding is to determine which of two or more theatres, which are substantially competitive, are to receive the pictures. To take an independent theatre and require it to bid against a chain theatre with which it is not in competition is simply a mechanism for avoiding any real competition in the licensing of pictures. In the instant case, Fox West Coast had available to it all of the product of 20th Century-Fox on the 7-day run. Thus, its programming was assured and it thus had the leverage to use excessive bids in order to assure the fact that the Paradise would be precluded from obtaining pictures on a 7-day run. Thus, the Fox West Coast purpose to prevent the development of competition in Westchester was served.

**E. The Conspiracy Prevented the Paradise Theatre From Operating on a Regular Seven-day Run Policy, Forced It to Run Old Pictures or Split Availability Programs and Thus Caused a Loss to the Paradise Theatre of Approximately \$38,000.00.**

Plaintiff produced evidence which showed that the Paradise Theatre's operation during the 52-week period from August 23, 1950 to September 22, 1951 resulted in a financial loss of \$38,000.00. There was no dispute that during this period the Paradise was not able to obtain a single 7-day run picture from Loew's or 20th-Fox for its operation although 70 to 80 pictures were necessary to operate on a 7-day basis. The testimony showed that as a result the Paradise was forced to play pictures released in prior years OR it was forced to play pictures on a 21-day availability or later OR it was forced to play split availability programs in which one picture was on a 7-day availability and the second feature

was on a later availability OR it was forced to hold over pictures from one week to a second week, while a new feature was added, thus depriving it of the access to the patronage which may have attended the theatre during the prior week. There was no dispute that such a policy would necessarily result in loss of patronage and loss of net receipts to the theatre.

There was no dispute as to the testimony that the 7-day run was more financially advantageous to an exhibitor than the policy which the Paradise was forced to adhere to. The testimony was uniform that the 7-day run is the most valuable run for a theatre except only for a Los Angeles first run. There was no dispute that the value of the run determines the value of the pictures on that run.

The testimony was that there were large expenditures for advertising on first run. Thus, it was apparent that the greatest financial benefit to be obtained from this advertising was to operate on an availability as early as possible before the effect of the advertising and exploitation wore off and the attention of the public was drawn to new pictures on first run. There was no dispute that increased gross receipts and increased profits result from operating on an earlier run on a regular basis.

Since Loew's and 20th Century-Fox together distributed approximately 80 pictures during the 52-week period involved here, it was clear that access to these pictures would have made it possible for the Paradise to operate on a regular 7-day run policy.

The evidence also showed that in the absence of the conspiracy, Loew's and 20th Century-Fox would have permitted the Paradise to operate on a 7-day availability. Thus, as we have pointed out above, the evidence was clear that Westchester was an excellent area for theatre patronage on an early run Loew's had no 7-day run

in Westchester and the evidence showed that it would have obtained increased revenues by obtaining a 7-day run in that area. Similarly, 20th Century-Fox had no 7-day run theatre in Westchester and as a distributor, its revenue would have increased from a 7-day run theatre in that area. Counsel for Fox West Coast conceded that if the Paradise were operating on a 7-day run, it would not have been in substantial competition with the Fox West Coast Loyola which operated on a first run [R. 1574]. Thus, it was clear that the over-all benefit to 20th Century-Fox and Loew's from the addition of a 7-day run theatre in the Westchester area would have resulted in the Paradise licensing pictures on this availability in the absence of a conspiracy.

The fact that Columbia, RKO and United Artists adopted this policy was further evidence from which the jury reasonably concluded that in the absence of a conspiracy between Loew's, Fox West Coast and 20th Century-Fox, the Paradise would have operated on a regular 7-day run policy.

The Paradise Theatre was comparable to the Loyola Theatre, which operated on first run, and to the Academy Theatre, which operated on a 7-day run. The profit and loss statements of these two theatres were introduced into evidence [Pltf. Exs. 45Q-1, 45Q-2, 79, 81]. On the basis of these records as to comparable theatres, and upon the basis of his expert experience in the operation of large numbers of theatres for a period of 35 years Schreiber testified that on the 7-day run, the Paradise instead of suffering a loss of \$38,000.00 would have obtained a profit of approximately \$35,000.00. Schreiber testified in extremely detailed terms as to the items of income and expense of the Paradise Theatre as it in fact operated and as it would have operated on the 7-day availability.

The jury's verdict of \$20,000.00 as against three of the groups of defendants was \$18,000.00 less than the actual loss of the Paradise Theatre during the 52-week period involved in the case at bar.

### CONCLUSION.

The evidence as to conspiracy and as to the fact of damage and the amount of damages clearly supported the verdict of the jury.

### III.

#### **The Rules of Law Applicable to This Case Require the Court to Sustain the Verdict of the Jury and Judgment Below.**

The rules of law applicable to an appeal which is based solely upon the question as to whether the trial court should have granted a motion for directed verdict, are well known to this court and need little comment. Long ago, in the Supreme Court decision of *Gunning v. Cooley*, 281 U. S. 90, 94, 50 S. Ct. 231, 233, 74 L. Ed. 720, the court said:

“In determining a motion of either party for a pre-emptory instruction, the court assumes that the evidence for the opposing party proves all that it reasonably may be found sufficient to establish, and that from such facts there should be drawn in favor of the latter all the inferences that fairly are deducible from them.”

As this court itself said in *Fidelity & Casualty Co. of New York v. Griner* (C. C. A. 9, 1930), 44 F. 2d 706, in “considering a case on appeal, we must accept the testimony which supports the verdict, if substantial, and reject the evidence to the contrary; such issues having been determined by the jury.”

More recently in *Las Vegas Plumbing Association v. United States* (C. C. A. 9, 1954), 210 F. 2d 732, 742, a Sherman Act antitrust case, this court said:

“The verdict of a jury will be sustained if there is any substantial evidence in the record to support it. In determining whether the evidence is sufficient to support the verdict, we must consider the evidence in the light most favorable to the government. *Glasser v. United States*, 1942, 315 U. S. 60, 69, 62 Sup. Ct. 457, 86 L. Ed. 680; *Woodward Laboratories Inc. v. U. S.*, 9th Circ. 1952, 198 Fed. 2nd 995.

“The credibility of the witnesses and the probative force of facts introduced in evidence are within the sole province of the jury. *Craig v. U. S.*, 9th Circ. 1936, 81 Fed. 2nd 816, at pages 827, 828; *Coplin v. U. S.*, 9th Circ. 1937, 88 Fed. 2nd 652, at page 664; *Morrissey v. U. S.*, 9th Circ. 1933, 67 Fed. 2nd 267, Certiorari denied, 293 U. S. 566, 55 Sup. Ct. 77, 79 L. Ed. 666.”

Moreover, in the light of appellants' brief, it is not unimportant to refer this court to the language of *Tennant v. Peoria and Pekin Union Railroad Co.*, 321 U. S. 29, 88 L. Ed. 520, at which the Supreme Court said:

“It is not the function of the court to search the record for conflicting circumstantial evidence or to take the case away from the jury on a theory that the proof gives equal support to inconsistent and uncertain inferences. The focal point of judicial review is the reasonableness of the particular inference or the conclusion drawn by the jury. It is the jury, not the court, which is the fact-finding body. It weighs the contradictory evidence and inferences, judges the credibility of witnesses, receives expert instructions and draws the ultimate conclusions as to the facts. The very essence of its function is to



select from among conflicting inferences and conclusions that which it considers most reasonable. (Citing cases.) That conclusion, whether it relates to negligence, causation, or any other factual matter, cannot be ignored. The courts are not free to weigh the evidence, and set aside the jury verdict, merely because the jury could have drawn differing inferences or conclusions or because judges feel that other results are more reasonable.”

#### A. The Conspiracy Issue.

While these principles seem elementary, yet in this case, as in so many appeals the error of the appellants lies in either this blindness or their unwillingness either to concede that evidence in favor of the appellee exists at all or to concede that the jury was entitled to make the adverse inferences, which it, in fact, made. No better example is present in appellant’s brief than on the issue of conspiracy and restraint of trade.

The title of appellant’s brief is “Opening Brief of Appellants, Fox and Loew’s”. One would believe from that title that there were only two appellants and one would believe from a reading of the brief that the key participation of Fox West Coast was a factor in some other case and not in the case at bar. This is not surprising, since in the trial of the case, while the *appellee’s* evidence directed primary attention at Fox West Coast and its conspiracy with the appellants, Loew’s and 20th-Fox, together with Universal, Warners and Paramount, the participation of the largest theatre circuit in the Pacific area in the conspiracy is unrecognized and unanswered by these appellants.

Thus, in appellant’s brief there is no consideration whatsoever given to the testimony against Fox West Coast Theatres. It will be recalled that the testimony showed that the reason that Loew’s and 20th Century-Fox,

Universal and Warners refused to permit the Paradise to license day and date was because Fox West Coast insisted on clearance over the Paradise. The testimony was expressly given by Marco Wolff, who represented the Paradise during its early period of operation. A letter was sent by Alex Schreiber to the distributors describing the conversation he had had with Loew's and with 20th Century-Fox and with Universal, Warners, Paramount, Columbia, United Artists and RKO in which each of these distributors had stated that the reason that they would not permit the Paradise to exhibit on a 7-day availability was the insistence of Fox West Coast on clearance over the Paradise and its insistence that the Paradise was in substantial competition. Yet, nowhere in the brief do appellants consider this a fact of participation by Fox West Coast.

It will be recalled that the witness, Marriott, testified that it was Fox West Coast who determined whether a theatre would play day and date with the Academy or would not. He testified that whether or not the Academy or Fox West Coast purchased the picture, it was Fox West Coast that made this decision. This testimony is ignored by appellants.

It will be recalled that Lehman testified that when he sought to obtain pictures on an equal availability with Inglewood from Columbia and from RKO, each of the branch managers informed Lehman that he must obtain the approval of Fox West Coast. In the case of RKO, Lehman called an employee of Fox West Coast and asked permission to play simultaneously with the Fox West Coast theatres and was refused. In the case of the Columbia picture, which opened at the Fifth Avenue Theatre, when Fox West Coast found that Columbia had permitted the Paradise simultaneously, the picture was removed from the Fifth Avenue program.

In specific answer to a question put by the court to Marco Wolff, he testified that all of the distributors

treated the Paradise differently than they did the Southside because Fox West Coast insisted upon clearance over the Paradise Theatre and insisted that the theatres were in substantial competition.

This evidence of direct participation of Fox West Coast in the decision of the film companies refusing the Paradise to operate on simultaneous availability with the theatres in Inglewood certainly gives rise to an inference that determination was the result of conspiracy between Fox West Coast and the distributors involved.

Of course, this evidence does not and need not stand alone; the jury was entitled to consider this evidence and was entitled to consider the background; the fact that Charles Skouras, on behalf of Fox West Coast, prevented any theatre from going into the Westchester area; that he specifically kept a competitor out of that area; that even when the theatre was under construction, he remonstrated with Schreiber, the Paradise president, concerning his going into the territory which Fox had carved out for itself. The jury was thus entitled to consider that Fox West Coast had adopted a plan for doing all that it could to keep out competition from the Westchester area.

The jury was entitled to conclude that when the Paradise opened, Fox West Coast then adopted the plan of doing everything that it could to weaken the competition of the Paradise Theatre. In this context, of course, the jury was entitled to consider the prior relationship which had been established between Fox West Coast, United Artists Theatres Circuit, Warners, Loew's and 20th Century-Fox. It was entitled to consider the fact that when it appeared that Fox West Coast and United Artists Theatres Circuit would be compelled to divorce their pooled theatres which had been used against independent competitors in violation of the antitrust laws, that a new plan was devised to substitute for the prior illegal relationships. The new plan was an informal one made

orally, not in writing. It was a plan whereby Fox, United Artists Theatre Circuit, Loew's, 20th-Fox, and other distributors agreed to allocate pictures in accordance with the desires of Fox West Coast. This agreed allocation, included the allocation of Loew's pictures to United Artists Theatre Circuit where there was no bidding and where there was bidding, included an agreement to allocate between UA Theatres and Fox West Coast to the exclusion of the Paradise. Certainly, express agreement as to restrictive practices to be followed permits a jury to infer the product of conspiracy.

Coming down into the Paradise area, the fact that at the very moment that Schreiber was attempting to obtain pictures from the distributors in March and April, 1950, there was a complete and comprehensive allocation of product engineered by Fox West Coast, United Artists Theatre Circuit and another exhibitor in the area with the connivance of all of the distributors. The evidence showed that this arrangement included a sham bidding arrangement in which each of the distributors send out bid letters, having the advance knowledge that a particular exhibitor was to be allocated the particular product of each distributor.

When the Paradise opened its doors, as has heretofore been described, it was clearly established that it was Fox West Coast's insistence upon clearance over the Paradise, which led to the rejection by the distributors of any right on the part of the Paradise to exhibit on the 7-day availability day and date with Inglewood. Pirosh, the Fox West Coast witness, admitted that he insisted upon having clearance over the Paradise. Bertero, the Fox West Coast president, testified that he informed Pirosh that he should obtain clearance over the Paradise.

In the execution of the clearance arrangements in the Inglewood area over Westchester, the discriminatory efforts of Fox West Coast were self-evident. Thus, in the

case of Universal, Fox West Coast had the veto power on whether the Paradise would be permitted to play simultaneously with it or not. The same thing was true with respect to Warners. The same thing was true with respect to 20th Century-Fox. The inference was clear that it was the Fox West Coast determination that led to the Loew's position that it would not permit Paradise to license an equal availability. It certainly will not do for the appellants to simply ignore this evidence or to ignore the clear inferences that the jury was entitled to make and urge that this does not constitute substantial evidence.

It may be argued by appellants that some of the evidence referred to above has reference to Fox West Coast actions with respect to Warners or Universal product and that these defendants were not found liable by the jury. But the jury is entitled to consider all of the evidence with respect to Fox West Coast in order to determine what its intent and its purpose and its methods were in the existing conspiracy. This is clear from the recent decision of this court in *Bryson v. United States*, 238 F. 2d 657.

The jury decision not to include Universal may well have been based upon the belief by the jury that Universal was coerced into its actions. The jury may have concluded the same with respect to Warners and with respect to Paramount. It will be recalled that Fox West Coast has the largest chain on the Pacific Coast. The jury may have selected Fox West Coast, Loew's and 20th-Fox as the most guilty of the conspirators and eliminated the others on the ground that the coercion showed that whatever action they took was against their will.

Be that as it may, the issue in a conspiracy case with respect to whether a verdict is supported by substantial evidence is not whether the verdict against the remaining defendants is consistent with the verdict in favor of



the others, but whether the verdict is consistent with the evidence. (*Bordenaro Bros. Theatres v. Paramount Pictures, Inc.*, 176 F. 2d 594.)

A significant difficulty with appellant's brief on this point is its calculated technique of relying on testimony by way of explanation and excuse instead of considering the necessary and permissible inferences to be drawn from that testimony, as the jury was entitled to infer. A second calculated technique is the process of dismemberment of testimony on the issues and the attempt to have this court weigh the inferences to be drawn from isolated elements of testimony independent of other aspects of the same issue. A typical example of this technique is the discussion of the incident involving Marco Wolff and Charles P. Skouras. Thus, from the statement by Skouras to an independent exhibitor who desired to build a theatre in Westchester, that he should not come into Fox West Coast territory, the appellants insist that only innocence may be inferred. When this testimony is added to the statements by Skouras remonstrating with the Paradise owner for coming into the district, this statement is assumed to permit only an inference of innocence. When the statements of Joseph Schenck, the executive of 20th-Fox, and a partner with Fox West Coast, to Schreiber which predicts that he would not have any pictures but that Schenck would have available pictures if he obtained a 60% or 70% interest in the Paradise theatre, only innocence can be inferred. When testimony is received as to the agreements between Fox West Coast, United Artists theatres allocating Loew's pictures across the State and allocating the pictures of all distributors wherever the theatres are in competition, again only innocence may be inferred. When testimony is received from the Loew's Pacific Coast Manager, George Hickey, to the effect that wherever bidding was involved, the allocation was arranged and employed, that each of the exhibitor circuits

informed him of that fact and that he has notes and memoranda of those conversations, again appellants insist that only innocence is involved. When an allocation agreement is set up in Inglewood during a substantial period involving all of the distributors and all of the exhibitors in the area, again only innocence can be inferred. When the testimony is produced concerning the insistence of Fox West Coast upon preventing the Paradise from playing day and date, the pattern of monopoly by Fox West Coast in seven day towns, the specific policy of exclusion of independents from simultaneous runs is demonstrated, each of these items of testimony is declared by the appellants' brief to require the inference of innocence.

But declarations by appellants on these points cannot stand examination under the law. Whereas we have pointed out above, this court has long recognized that it is the inferences drawn from the testimony as a whole which the jury is entitled to make and if such inferences, considering the testimony as a whole, constitute substantial evidence of the fact, then this court will not disturb the finding of the jury on that fact.

Certainly, if the jury believed, as it must have believed, that Fox West Coast was the moving influence in the erection and the maintenance of the conspiracy, as well as its beneficiary, then the roles of Fox West Coast and 20th-Fox become clear.

Loew's participation in the allocation of pictures to Fox West Coast and United Artists Theatres Circuit came from the testimony of Hickey. With respect to the Paradise, he testified that the reason that the Paradise was not permitted to play an equal availability, was that there was no theatre in the city limits playing Loew's pictures on the 7-day run. He also testified that all of the theatres in which Loew's played its pictures on the 7-day run were Fox towns. The obvious lack of candor

in the testimony concerning the stated reason for the refusal to permit the Paradise day and date exhibition, together with the real reason, revealed by the fact that all of the 7-day towns were "Fox towns," and the express testimony of agreement by Hickey and Fox West Coast and United Artists Theatres Circuit to allocate Loew's 7-day pictures, certainly permitted the jury to conclude that Loew's was participating in the conspiracy with Fox West Coast.

Moreover, Loew's by contract, entered into an agreement with Fox West Coast to grant clearance on behalf of the Fox West Coast theatres over the Paradise Theatre. Such contract relationships were *per se* illegal if, as was established, the Paradise and the Fox Theatres were not even in substantial competition. Since the jury obviously found that there was not substantial competition, expressly and by written agreement, Loew's entered into the conspiracy with Fox West Coast.

But Hickey's handling of the so-called bidding which, he insisted, the Paradise participate in, is even further evidence. Paradise bids were rejected, even though Hickey testified that it was the custom to permit a picture to be exhibited in a new theatre in order to determine its grossing potentialities. Loew's not only rejected the Paradise request for equal availability prior to its having any knowledge of the competitive relationship between the Paradise and the Fox theatres, but Loew's rejected the Paradise bids without any such knowledge. In fact, Loew's did not exhibit a single picture in the Paradise on the 7-day availability from the day the theatre opened through the end of the damage period, September 22, 1951.

Finally, even on those pictures, which, in the course of the bidding, all bids were rejected, Hickey testified that Loew's negotiated the 7-day run with exhibitors. No

such negotiation and no such offer was made to the Paradise, even though the documentary evidence was introduced to show the constant request by the Paradise to license and negotiate for pictures with Loew's.

In the light of all of this testimony, the jury was certainly permitted and reasonably required to conclude that Loew's participated in the conspiracy with Fox to prevent the Paradise from obtaining a 7-day availability.

The role of 20th-Fox in the conspiracy with Fox West Coast was even more clearly established. Joseph Schenk, an executive of 20th Century-Fox was also the president of United Artists Theatres Circuit. This circuit entered into agreements with Fox West Coast concerning Loew's product and entered into direct agreements with Loew's. Spiro Skouras, the president of 20th Century-Fox, was the brother of Charles P. Skouras, the president of Fox West Coast Theatres and the brother of George Skouras, who, it was stipulated, from 1949 on was an officer of United Artists Theatres Circuit. The knowledge and participation of 20th Century-Fox in the arrangements to allocate pictures in Los Angeles and in the Westchester and Inglewood areas was clearly established.

The evidence clearly showed that 20th Century-Fox's policy was designed to prevent the Paradise from ever becoming a competitor on the 7-day availability in Westchester. Thus, the testimony showed that even when the Loyola did not exhibit a picture, such a picture was not offered to the Paradise, although at the same time, that picture was exhibited in a theatre belonging to the United Artists Theatres Circuit, Inc. The evidence showed that throughout the Los Angeles area, it was the practice to have move-overs, *i.e.*, exhibition of motion pictures at a first run theatre and then the exhibition in a second theatre without the elapse of any time. There was no move-over theatre in Westchester and 20th Century-Fox refused the

Paradise that availability. The evidence showed that 20th Century-Fox participated with Fox West Coast in determining that no 7-day theatre would be permitted to operate in Westchester. Thus, it was clearly Fox West Coast who determined that the Paradise should not exhibit 20th Century-Fox pictures on a 7-day run in Westchester. Although the evidence was clear that there was no competition between the Paradise and the 7-day run theatre which 20th Century-Fox had in Inglewood. The testimony of Stoner, the 20th Century-Fox witness, that when the Southside was permitted to play simultaneously revenue to 20th Century-Fox increased in the area and the continuous refusal to permit the Paradise to play on the 7-day availability in Westchester, where there were no 7-day theatres, corroborate the inference of participation of 20th Century-Fox in the alleged conspiracy [R. 2489].

Appellants would have this court believe that the simple statement of an academic homily that the distributor has a right to sell its own theatre is the answer to a Sherman Act charge, and that this amounts to exemption. But this argument was answered by this court as recently as March 29, 1957. On that date, this court handed down the decision in *Flintkote Company v. Lysfjord, et al.*, March 29, 1957 ..... F. 2d ....., No. 15005.

In that case, appellants, who had been found to have participated in an illegal conspiracy in violation of the antitrust laws by a trial jury, sought to escape the result of the jury verdict upon the assertion of the principle that a seller may choose his own customers. This, it was argued, was an absolute defense to a suit by one who was denied access to the seller's goods pursuant to a conspiracy which was established by the jury's verdict. The court said this:

“It is true that one engaged in private enterprise may select his own customers, and in the absence of



an illegal agreement, may sell or refuse to sell a customer for good cause, or for no cause whatsoever. But it is not for the seller to finally decide that it was for a good business reason, or no reason, that he refused to deal. That decision, placed in its proper prospective of circumstances and facts known to the seller, must be judged by the trier of facts, to determine if it was an innocent and lawful exercise of the seller's private right, or an act which showed knowing participation in an unlawful conspiracy.

“Were it otherwise, there could never be a civil judgment nor any criminal conviction against any manufacturer of products flowing in interstate commerce. He could merely state—‘despite my knowledge of a conspiracy which existed, which I knew to be unlawful, I am innocent and cannot be held liable because I say I exercise my business judgment, and I can refuse to sell to anyone, and that is lawful no matter what the circumstances may be.’ . . .”

The court answered this proposition directly.

“The rule of freedom of sale to anyone or no one is not absolute. The *Colgate* case (U. S. 300), ‘was not intended to give blanket sanction for individual discretion for refusal to deal. The court soon determined that its holding did not stand to protect a course of dealing which inferentially spelled out the factor of agreement that *Colgate* lacked. More important, the court's landmark decision in *Federal Trade Commission v. Beechnut Packing Co.*, places any refusal to deal in its business prospective and then against the full facts scrutinizes all pertinent antitrust prohibitions, the trade pattern suggests.

“‘Viewed within the larger business setting, even individually conceived refusals to deal may become an integral element in a violation of Sec. 1 of the

Sherman Act. . . . Also Sec. 2 may forbid refusal to deal for monopolistic ends. *Eastman Kodak Co. v. Southern Photo Materials Co.*, 273 U. S. 359 (1927)' (Report of the Attorney General's National Committee to Study the Antitrust Laws, March 21, 1955).

"The decisions have placed an evaluated refusal to deal in the business setting in which they appear. While refusals to deal in themselves are legally protected, they are examined in their market context. Only thorough-going factual inquiry into the surrounding business circumstances can characterize a refusal to deal as a part of a restrictive course of conduct incompatible with antitrust objectives."

Thus, as this court held, refusals to deal and the so-called right to sell, are all to be evaluated by the trier of facts.

This principle, of course, is directly applicable to the contention made on behalf of appellant, 20th-Fox, as to the right to sell, here to a corporation in which indirectly it owned all of the stock. The same principles are applicable. It was for the trier of fact to determine whether the refusal to sell a 7-day run to the Paradise was pursuant to a conspiracy with Fox West Coast and Loew's, or whether it was actuated by individual independent business motives. The absolute right asserted by appellants without regard to the facts or circumstances cited above simply ignore the basic principles of law applicable to decisions under the antitrust laws.

This holding by this court is directly in accord with the decisions of the Supreme Court of the United States and the Courts of Appeals of other circuits. Thus, the Supreme Court said, in *American Tobacco Co. v. United States*, 328 U. S. 781, 809, 66 S. Ct. 1125, 1139, 90 L. Ed. 1575:

"It is not the form of combination or the particular means used, but the result to be achieved that the

statute condemns. It is not of importance whether the means used to accomplish the unlawful objective are in themselves lawful or unlawful. Acts done to give effect to the conspiracy may be in themselves wholly innocent acts. Yet, if they are part of the sum of the acts which are relied upon to effectuate the conspiracy which the statute forbids, they come within its prohibition. . . . The essential combination or conspiracy in violation of the Sherman Act may be found in a course of dealing or in other circumstances as well as in any exchange of words. *United States v. Schrader's Son*, 252 U. S. 85, 44 Sup. Ct. 251, 64 L. Ed. 471."

The application of this principle has been widespread. Thus, in *Parmelee Transportation Co. v. Keeshin*, 144 Fed. Supp. 480, a complaint was filed by the operator of a transfer service which hauled passengers between train stations in the City of Chicago. The complaint alleged that pursuant to a plan, one individual, Hugh W. Cross, because a member of the Interstate Commerce Commission; that one, John L. Keeshin, promised Cross a valuable consideration if Cross would persuade the individual railroad presidents to use their influence to cause the Chicago Terminal Lines to eliminate plaintiff and to transfer the business and the contract to a corporation to be formed by Keeshin. This result was to be accomplished by representations by Cross that he would exercise his influence on the Interstate Commerce Commission in their favor. Ultimately, the contract was transferred.

Defendant railroad companies moved to dismiss the complaint upon the ground that it failed to state a claim. The contentions made by the defendants were as follows:

"The first of those objections takes the form of a syllogism and runs as follows: The fact that the contract with Keeshin for terminal transfer services was

an exclusive one did not make it illegal as a monopoly; that such contract was made by the railroads acting together did not indicate the existence of a monopoly, since they were not competitors they were in a position of a single buyer, and as such free to deal with whom they pleased; therefore, no violation of the antitrust laws has occurred.”

The court pointed out

“As in all such arguments, the conclusion must fail if either the major or minor premises is in error. . . . The flaws in the proposition lie in the minor premise; the assumption that the railroads could lawfully act together to grant a transfer contract ignores completely the complaint’s allegation that the purpose and effect of the joint action was and is to prevent competition in bidding for contracts for terminal service.”

The court said

“Acts otherwise lawful are ‘within the prescription of the antitrust statutes, if done for the purposes prohibited by the antitrust laws, *i.e.*, to eliminate competition.’” Citing *Noerr Freight v. Eastern Railroad Presidents Association*, D.C., E. D. Pa., 1953, 113 Fed. Supp. 737, 742; see, also, *Kobe v. Dempsey Pump Co.* (10th Cir., 1950-1952), 198 F. 2d 416, 459; and *Cape Code Food Products v. National Cranberry Association*, D. C. Mass., 1954, 119 Fed. Supp. 900, 907.

The individual acts in *Parmelee Transportation Co. v. Keeshin*, obviously were lawful, *i. e.*, the appointment of individuals to an office in the I. C. C., the execution of an exclusive contract, but the combination of the acts pursuant to a conspiracy violated the antitrust laws.

Another railroad case applying this same principle is *Noerr Motor Freights, Inc. v. Eastern Railroad Presi-*

*dents Conference*, U. S. D. C. E. E. Pa., 26 L. Wk. 2181. There the gist of the complaint was that the railroads had conspired to use a public relations firm to conduct a propaganda campaign to crystallize motorists resentment against the expense and safety features of heavy truck operation over the roads and to arouse public interest in such new methods of financing public highways as a ton-mile tax. One of the important aspects of the activities was of legislation, and another was the vilification of the trucking industry.

The railroads argued that each of these acts constituted an absolute right. That is, there was a right to obtain the passage of legislation and there was certainly a right to state their opinions as to the existence of evils in the trucking industry. The court quoted from *Slick Airways v. American Airlines*, 107 Fed. Supp. 199, in which there the court had said:

“While it may be questioned whether any of this alleged activity by defendants of itself constitute illegal conduct, it is fundamental . . . that legal means may be utilized to accomplish the unlawful objective of conspiracy.”

The court in the *Noerr* case came to the same conclusion. Thus, the court said:

“This court is not condemning the field of public relations. It is only condemning as it would be used in this case, as an instrumentality of destruction rather than one of promotion. Neither does the court determine it illegal for an industry to seek any and every proper legislative goal; nor to enlist the support of other persons in obtaining legislation. But it is illegal to use the practices and methods shown by the record of this case to destroy a competitor's good will and to use third parties as fronts to carry out a conspiracy to destroy the competitor.”



Again, the principle seems self-evident, and yet the defendants ignore it completely in their brief.

The corporate relationship between Fox West Coast and 20th Century-Fox is, of course, under the antitrust laws, of no moment to the decision made by the jury that a conspiracy existed. In both *Kiefer Stewart Co. v. Joseph F. Seagram & Sons, Inc.*, 332 U. S. 218, and *United States v. Timkin Roller Bearing Co.*, 341 U. S. 593, conspiracy was found between related corporations. These very defendants, 20th Century-Fox Film Corporation and the parent of Fox West Coast Theatres Corp., National Theatres, Inc., were found to have violated the antitrust laws in *United States v. Paramount, et al.*, 334 U. S. 131 (1948).

The fact that one defendant owned the stock of another defendant was of no moment where one of them has a plan for violating the antitrust laws to which the other related corporation adhered. Here, the evidence was clear as to the plan of Fox West Coast to keep out and to weaken competition in Westchester and the evidence was clear that Fox West Coast participated with other corporations in carrying out this scheme that the obvious knowledge and adherence by 20th Century-Fox to the plan of Fox West Coast requires that the same principle of law be applicable to 20th Century-Fox as to any other defendant. (*Milwaukee Town v. Loew's*, 190 F. 2d 561.)

**B. Substantial Evidence Supported the Jury's Verdict That the Appellants Conspired to Impose Unreasonable Clearance Against the Paradise Theatre.**

The jury was instructed that it was unlawful and a violation of the antitrust laws for the appellants to conspire to impose unreasonable clearance against the Paradise Theatre. Such a clearance would be unreasonable

*per se* if the theatres obtaining the clearance were not in substantial competition with the Paradise. The appellants do not deny this rule of law.

*J. J. Theatres, Inc. v. 20th Century-Fox Film Corp.*, 212 F. 2d 840.

As summarized in this brief, the evidence introduced was more than adequate to demonstrate that the Paradise was not in substantial competition with the other theatres which obtained clearance over it.

In their treatment of the issue of substantial competition appellants' brief graphically demonstrates the practice of putting partisan blinders on with respect to adverse evidence and ignoring the weakness of the evidence relied upon. The factual testimony of Schreiber, Lehman and Wolff; the inferences to be drawn from the admission that the Southside and the Academy were recognized to be non-competitive; the testimony of the 20th Century-Fox witness Stoner, to this effect, the testimony concerning the restricted drawing area of neighborhood theatres, all of them rendering testimony and evidence supporting the jury verdict is ignored by appellants.

Moreover, appellants ignore the weakness of the evidence which they rely upon. The appellants make a comparison of three pictures exhibited at the La Tijera and Paradise simultaneously and three additional pictures exhibited exclusively at the La Tijera purporting to show that the La Tijera and Southside were not in substantial competition from which a second inference is drawn that the Paradise was in competition with other theatres in Inglewood.

At the outset, this argument ignores a fact which was conceded by literally every witness who took the witness stand. It was conceded that the Paradise and the Southside theatres, located 6.9 miles away from each other, were not in substantial competition with each other. Thus,

the jury was entitled to conclude that factors other than substantial competition must have entered into any differences shown in the relative grosses of a theatre located 6 miles away, such as the La Tijera.

In the case at bar, the appellant simply failed to introduce comprehensive evidence on the subject. No evidence was introduced as to the second features, the season of the year or the state of the weather, or any other of the variable factors which can affect the grosses in a theatre *on a particular day*. Certainly as against the express testimony of their witnesses as to the matter of substantial competition the jury was entitled to give little if any weight to any of the *three-picture* survey *re* the La Tijera and Southside.

Appellants make reference to an alleged survey made on *one* day as the patronage at the Academy Theatre. The survey was testified to by a witness whose credibility was seriously attacked. Thus, the evidence showed that the witness was of the opinion the Paradise and Southside were in substantial competition, although each and every experienced theatre man in the business testified to the contrary. The witness testified that the areas from which theatres draw patronage gets smaller as the run gets later. Thus, he testified that in his opinion, generally, that a first run theatre draws from a wider area than a 7-day run theatre. But his own survey showed that the Loyola Theatre drew from a 4-mile radius and the purported Academy survey showed the Academy drew from the same 4-mile radius. The Loyola Theatre was admitted to be a first run theatre from the first day of its opening, and the Academy Theatre was admitted to be a 7-day run theatre. So there was a direct and definite conflict in the testimony of the witnesses.

In the light of such a discrepancy the jury was entitled to completely ignore the testimony of the witness.

Moreover, the jury was entitled to take into consideration in coming to its conclusion that since the witness was employed by the defense and his only prior employment in these matters had been by defense counsel defending motion picture antitrust cases that there was bias and prejudice in his handling of the survey.

The patent fact was not only that the jury was justified in believing evidence that the Paradise Theatre was not in substantial competition with the La Tijera or any other theatres in Inglewood, but that the issue of substantial competition was used as a deliberate sham. Witness after witness, representing appellants, were called to the witness stand who testified that their reason for refusing a simultaneous run to the Paradise Theatre was that the theatres were in substantial competition, but testimony as to the meaning of the term amply revealed that it had no impact whatsoever on the actual decisions taken.

Appellants again ignore opposing evidence when they argue that it was to the financial advantage of Loew's to refuse the Paradise Theatre a simultaneous run in Westchester. It will be recalled that Stoner, the 20th Century-Fox witness, testified that when the Southside exhibited, for a full year simultaneously with the Academy, the revenue of 20th Century-Fox from the area increased—this despite the fact that the Southside was a larger theatre than the Academy and located  $3\frac{1}{2}$  miles away. The evidence showed that Loew's had no theatre in Westchester exhibiting pictures on a 7-day availability; that obviously the revenue of Loew's would increase if it took advantage of the opportunity to tap the Westchester patronage on a 7-day availability. Both Schreiber and Wolff testified affirmatively in support of this proposition.

The appellant, while ignoring all of the evidence on this subject favorable to appellee, insist on argument from distorted charts. A prime example is the use of a com-

parison of gross receipts of the pictures, "King Solomon's Mines" and "Born Yesterday," without recognition that the exhibition period for "King Solomon's Mines" was during the Christmas-New Year holiday, a theatre boom period (App. Br. p. 44). Again appellants' brief argues (p. 46) from a schedule which purportedly shows that out of the ten top grossing pictures at the Paradise, three were Loew's 21-day pictures which had played only after one prior run. It is pointed out that these grosses compared favorably with the remaining seven 7-day pictures which were played earlier simultaneously at the Paradise with other theatres. But the schedule is distorted because it fails to show the artificial restrictions on the 7-day pictures played at the Paradise in that they always played either with old pictures as the second feature which the patrons had seen, or with hold-over pictures, *i.e.*, pictures that had already been exhibited the prior week in the Paradise theatre. For example: "Sunset Boulevard" played with a Universal 14-day picture. The first week of "Born Yesterday" included a 21-day Warners picture; the second week included a 21-day Paramount picture and the third week included an Eagle-Lion picture. The picture "Samson and Delilah" was not truly a 7-day run picture since it had been exhibited prior thereto in the Inglewood area. The Universal picture, "Desert Hawk," was exhibited as a 14-day picture with a second feature; a Columbia picture, "In a Lonely Place," was exhibited with a 14-day picture; a Warner's picture, "Break Through," was exhibited with a 21-day Republic picture. The Warners picture, "Pretty Baby" was exhibited the first week with a 21-day Republic picture. The gross receipts were artificially restricted by the lack of the availability of another 7-day run picture as a program. Had there been such a 7-day run program at the Paradise, obviously these 7-day run pictures would have been far later than the 21-day Loew's pictures which are indicated. No reference is



made to the artificial restriction in appellants' schedule. Moreover, appellants make no reference to box office quality of the comparable pictures, which makes utterly useless a comparison of the pictures.

In their brief, appellants discuss the film rental received on the pictures "Good By My Fancy," "Glass Menagerie," and "The Enforcer" (p. 48).

A demonstration of the fact that broad conclusions from examples having to do with untested and erroneous samples is clear from the discussion of these three pictures in appellants' brief. Thus, they argue that since the picture "Glass Menagerie" had two 7-day runs, two 14-day runs and one 21-day run and earned film rental of \$3,442.00 and since the picture "Good By My Fancy" of 21-day run and earned a film rental of only \$1,941.00, that it follows that Warners, by increasing the number of 7-day runs has reduced its total film rental.

The first answer to this contention is shown by the fact that in the Los Angeles area (in contrast to nationwide) Glass Menagerie was about 13% more valuable as a picture box office wise than was "Good By My Fancy." While this does not explain the entire difference, the exhibition situation in Inglewood demonstrates the fallacious character of using a single example. Thus, the picture Glass Menagerie played as the top feature in the Southside and Academy theatres during the week of November, 1950. In both theatres the picture was shown as the top feature. On the picture "Good By My Fancy," however, which played at the Southside, UA and La Tijera, the Southside played the picture as a second feature, with the top Paramount picture "Lemon Drop Kid." The importance here is, as shown by the testimony of Greenberg, the Southside only paid \$400 for the picture "Good By My Fancy." The reason was that it is customary in the film business that if the top feature is a percentage picture, as was the "Lemon Drop Kid," the second feature is sold at a minimum top rental.

The evidence also showed that the single 21-day run on "Good By My Fancy" was played at the Imperial Theatre, but even that so-called run was unique, in that it was only for four days (the dates of exhibition of "Good By My Fancy" at the Imperial were from June 6 to 9, 1951). Thus, the picture "Good By My Fancy" was not only an inferior picture, but it was exhibited at the third theatre as the lower half of a double bill, reducing the film rental significantly and for some reason which is totally unexplained in the record the single 21-day exhibition was for half of the usual period. We don't know whether it was the weather, the summer slump, some special event or occurrence or what other factors caused the Imperial to terminate the exhibition.

Since the conclusion sought to be drawn from the appellants is no better than the other figures and other facts and since these facts show their unique character, they were useless to the jury in arriving at their conclusions.

Appellants argue that the refusal of Loew's to grant the Paradise Theatre a 7-day run was because by granting such a run a precedent would have been established for other areas to obtain 7-day runs. Appellants also argue that if they had granted 7-day run to the Paradise additional theatres would have made the same claim in the area. If there is any fact which the jury is entitled to determine it is that the decision was the result of conspiracy and not the result of such considerations. In the case at bar the allocation of product arrived at by agreement of Loew's, 20th-Fox, West Coast and others, was not the result of independent decision by Loew's, but the result of collective action.

### **C. The Issue of Bidding.**

What has been said above with reference to the unlawfulness of employing lawful means for an unlawful end, is directly applicable to the contentions made by ap-

pellants as to bidding. Here again, the substance of the argument made in appellants' brief is that, as to Loew's, Inc., the fact that it refused a day and date availability and required Paradise to bid against theatres in Inglewood, is an absolute defense to a charge under the antitrust laws. But where, as here, the bidding against theatres not in substantial competition and the granting of clearance by Loew's to the Fox West Coast Theatres over the Paradise, was part and parcel of a conspiracy to prevent the Paradise from becoming an effective competitor in the Westchester area, the facts completely destroy appellants' argument.

But in this area, we have the guidance of the Supreme Court of the United States. In *United States v. Paramount, et al.*, 334 U. S. 131 (1948), 20th Century-Fox, Loew's and the parent of Fox West Coast, National Theatre Corporation, were charged with combining and conspiring to violate the antitrust laws in the distribution and exhibition of motion pictures throughout the United States. In general, the charges made in that case were the same as are involved here, *i.e.*, the favoring of the large circuits of the country over the independent exhibitors pursuant to conspiracy. The trial courts' findings in 1946 in *United States v. Paramount, et al.*, was accompanied by injunctive provisions which set up competitive bidding as the substitute for terminating the relationship between 20th Century-Fox and National Theatres Corp., and the other distributor and exhibitor defendants, and also set up competitive bidding as a means for relieving the other ills found to have existed in the *Paramount* case. The remedy was categorically rejected by the Supreme Court. The reasons given by Mr. Justice Douglas are applicable to the case at bar.

Thus the Court pointed out that competitive bidding favored the large circuits with the "longest purse" and

therefore, in the long run, could be used as a means of restraining competition rather than enlarging it. The Court specifically said:

“Our doubts concerning competitive bidding system are increased by the fact that defendants who own theatres are allowed to pre-empt their own theatres. They thus start with an inventory which all other theatres lack. The latter have no prospect of assured . . . except what they get by competitive bidding. The proposed statement does not offset in any way the advantages which exhibitor defendants have by way of theatre ownership. It would seem, in fact, to increase them.” (334 U. S. 131, 165, 92 L. Ed. 1261, 1296.)

The courts have uniformly held that competitive bidding standing alone is not an absolute defense to a charge of violation of the antitrust laws. Thus, in *William Goldman Theatres, Inc. v. 20th-Century-Fox Film Corp.*, U. S. D. C., E. D., Pa., Feb. 11, 1957, CCH Trade Rec. Paragraph 68,638, the complaint by a theatre exhibitor included an allegation that 20th Century-Fox had conspired with others to limit and restrain the plaintiff's ability to compete and toward that end brought into effect competitive bidding, in an effort to deprive the plaintiff of a fair supply of first run pictures and to enable 20th Century-Fox to exact excessive film rental. The allegation was made that 20th Century-Fox had, as a result, refused to license its pictures to plaintiff unless plaintiff would comply with the “competitive bidding” system.

Defendants moved to dismiss upon the grounds that competitive bidding was an absolute bar to a suit under the antitrust laws. The court denied the motion. The court said:

“As for the first reason, defendants are apparently under the impression that the mere requirement of

competitive bidding for a product prevents conduct and dealings involving that bidding from coming in conflict with the antitrust laws. That is not the law. See *U. S. v. Paramount Pictures*, 334 U. S. 131, 1948; *Maple Drive-In Theatre Corp. v. Radio Keith Orpheum*, CCH Trade Regulations Reports, Par. 68,422 (S.D. N.Y. June 26, 1956).”

As the court there put it, Universal argued that assuming the existence of a conspiracy, competitive bidding as a matter of law terminate any impact on the plaintiff and requires summary judgment. The court denied the motion saying:

“The Supreme Court has recognized the potentiality of competitive bidding as a means of restraining rather than enlarging competition in the exhibition of motion pictures. *U. S. v. Paramount Pictures, Inc.*, 334 U. S. 131, 161 ff., 1948. The opinion in the *Paramount* case does not permit a conclusion that competitive bidding per se, even among competitors, is inconsistent with the continuing attempt to discriminate. The reasonableness of the system must be determined from the manner in which it is operated, the intent of the parties and its actual effect on the plaintiff. Proof that the defendants had been engaged in a conspiracy to discriminate against the drive-ins prior to 1933 certainly would be relevant in evaluating their conduct subsequent to that time.”

Bidding among competitors, under the law, is not per se inconsistent with a continuing attempt to discriminate. This is the complete answer to the position taken by appellant.

But, even more significant, is the fact in this case that the evidence showed, that the jury found, that the theatres against whom Loew's required the Paradise to bid were not in substantial competition and that, in fact,



the Paradise and those theatres were not competitors. Thus, it would follow that a jury could consider such competitive bidding between non-competitors as an instrumentality of discrimination.

#### IV.

#### **There Was Substantial Evidence of the Fact of Damage to Appellee's Business and Property.**

There was no dispute that the operation of the Paradise Theatre from September 23, 1950, to September 22, 1951, resulted in financial loss to appellee. Schreiber testified that on a 7-day run policy the Paradise would require 35 to 40 first features and an equivalent number of second features. There was no dispute that during the damage period appellee obtained no 7-day run pictures from appellants Loew's and 20th-Fox and only a handful from the 3 other defendants.

Moreover, even with respect to these pictures appellee was forced to exhibit them at the same time they exhibited older pictures which had been released in previous years or were late availability pictures. That Paradise was forced to hold over part of a program for a second week, while part of the program was new, thus depriving it of access to the patronage which may have been to the theatre during the prior week. As a result the Paradise Theatre was prevented from operating its theatre on a regular 7-day run basis.

There was no dispute that the 7-day run is more advantageous to an exhibitor than the policy which the Paradise was in fact forced to adhere to. There was no dispute that increased profits and increased gross receipts result from operating on an earlier run on a regular basis.

Schreiber testified that on a 7-day run policy he would need 35 to 40 first features and an equivalent number of second features. It was stipulated that Loew's and 20th

Century-Fox distributed 68 pictures during the 1950-51 season. Thus, access to these pictures tendered to RKO would have made it possible for the Paradise to operate on a 7-day run policy. Without access to these pictures, the Paradise was forced to operate on an economically disastrous policy.

The jury was entitled to conclude that the loss of access to 20th Century-Fox and Loew's products resulted in injury damage to the Paradise in that they provided all and certainly some part of the supply which was necessary to operate the Paradise on a 7-day availability. This more than adequately supports the finding of the fact of damage in this case.

Moreover, appellants argue that the fact that Warners, Universal and Paramount were not found liable by the jury indicates that *their* product was in fact available. Appellants assert that no conspiracy was found by the jury with respect to the product of these three companies. This assumption is of course erroneous. The jury found that appellants had engaged "in a conspiracy with each other to monopolize or unreasonably restrain interstate commerce in the licensing of motion pictures to plaintiff for exhibition in the Inglewood-Westchester area on a 7-day run" [R. 2846].

It is appellants who convert this interrogatory into a purported restriction of the conspiracy found to pictures of Loew's and 20th Century-Fox. The jury was entitled and undoubtedly did consider all of the evidence involving Fox West Coast activities and was justified in finding that Fox West Coast, Loew's and 20th-Fox prevented the Paradise from getting the picture of *all* the distributors through *coercion* upon Warners, Universal and Paramount.

Deprivation of all of Loew's and 20th-Fox product *or* of all of the product of these distributors *and* Warners, Universal and Paramount product sustains the jury verdict.

*Wolff v. National Lead Co.*, 225 F. 2d 427, 433 (9th Cir., 1955), is of course completely irrelevant here. There the trial judge found that there was no evidence of conspiracy to send to the jury. In the case at bar the jury has specifically found conspiracy between Fox West Coast, Loew's and 20th Century-Fox. In the *Wolff* case there was no suggestion that the defendants restricted the availability of the so-called "substitute" product. Here the evidence is comprehensive as to the activity of the conspiracy, particularly through Fox West Coast in preventing the Paradise Theatre from obtaining access to Warners, Universal and Paramount product.

Moreover, in the *Wolff* case this court took great pains to emphasize that plaintiffs there made a great amount of profit and that the evidence did not sustain the proposition that an additional profit, larger than the figure shown in that case, would have been realized by an additional supply of titanium. In the case at bar the plaintiff suffered losses and the availability of Loew's and 20th Century-Fox product *certainly* would have made those losses less severe than they were. The jury in allowing only \$20,000 in damages may well have concluded that Loew's and 20th Century-Fox product would have made it possible for the Paradise to suffer that much less loss than it had in fact suffered. From all of these grounds the fact of damage adequately appears.

The evidence clearly showed the fact that the Paradise would have obtained a sufficient supply of 7-day run pictures had the conspiracy not been in existence. The Westchester area as a theatre patronage area for early runs was a very successful section of the city. Acting in its own interest without conspiracy, Loew's undoubtedly would have permitted a theatre in Westchester to become the outlet for Loew's pictures there on the 7-day run. Otherwise, with the Loyola Theatre playing substantially all of 20th Century-Fox product Loew's, was totally un-

able to obtain any access to the 7-day run customers in the Westchester area.

Appellee followed the route laid out by cases such as *Bigelow v. RKO-Radio Pictures*, 327 U. S. 251 (1946); *William Goldman Theatres v. Loew's*, 150 F. 2d 738, approved by this court in *Flintkote Co. v. Lysfjord*, ..... F. 2d ....., No. 15005, filed March 29, 1957, in proving damages. Thus appellee produced testimony to show that the Academy Theatre was a comparable theatre operating on a comparable run to that from which the Paradise was erroneously excluded. Of great importance is the fact that appellants introduced *no* evidence of *any other theatre* to counter the testimony of comparability with the Academy. If appellants desired to show that a 7-day run theatre would return *lesser* gross receipts, and that the Academy comparison was inadequate, they need only have turned to the innumerable theatres which appellant Fox West Coast operated for examples. In the Inglewood area, appellants put no testimony in with respect to the Fifth Avenue or the Fox Inglewood or any other theatre in order to provide an alternative guide to the jury. Certainly in the face of this inaction appellant cannot now complain that the guide was inadequate.

Appellants' brief argues (p. 59) that in order to make use of a theatre as a comparable theatre that theatre must be exhibiting precisely the *same* pictures which appellant sought and which were denied to him unlawfully.

No case supports this argument. Comparability as to size, equipment, location, run—these are the only tests and even these facts are for the jury to determine. (*William Goldman Theatres v. Loew's*, 150 F. 2d 738; *Milwaukee Towne v. Loew's*, 190 F. 2d 561.)

The decision means anything other than comparability as to physical and locational characteristics having the run or availability sought by the injured plaintiff. In this court's decision in *Flintkote v. Lysfjord* (..... F. 2d .....),

No. 15005, this court describes the three types of evidence generally approved as sound evidence for damages:

- (1) Business records of the plaintiff or his predecessor before the conspiracy arose;
- (2) Business records of comparative but unrestrained enterprises during a particular period in question;
- (3) Expert opinion based on items one or two.

Appellees' evidence concentrated primarily upon items two and three and it supported the jury verdict. The Paradise is somewhat larger; it is also newer. Its expense of operation was somewhat comparable to the Academy, but any changes in the Paradise expense figures were detailed and never seriously questioned.

Appellee's president's expert opinion was also based on all the factors, including the business records of the comparative theatre. The evidence was more than adequate.

**A. Appellants Failed to Carry Their Burden of Proof With Respect to the Issue of Mitigation of Damages.**

Appellants reconstruct their "fact of damage" argument into an argument which is equivalent to an argument mitigation of damages. Conceding for the sake of argument that the appellee was deprived of Loew's and 20th Century-Fox product appellees argue that the verdict of the jury does not cover Warners, Paramount or Universal (p. 53). As we have argued above, the specific interrogatory answered by the jury showed that they found that these appellants had engaged in a conspiracy with respect to the licensing of motion pictures to appellee on a 7-day availability. The 7-day run conspiracy was charged and was proven. The verdict establishes that Fox



West Coast coercion pursuant to the conspiracy with Loew's and 20th which had its effect on preventing the Paradise from obtaining Warners, Universal and Paramount products as well.

Moreover, in looking at the verdict only in terms of Loew's, 20th Century-Fox products, appellants had the burden of proof to establish to the satisfaction of the jury that the appellee had not taken reasonable steps to mitigate damages.

In *In re Kellett Aircraft Corp.*, 186 F. 2d 97, the court states the rule universally recognized "whether or not the buyer's obligation to mitigate damages had been discharged" depends on the reasonableness of its conduct. In this connection, "reasonable conduct" is to be determined from all the facts and circumstances of each case and must be judged in the light of one viewing the situation at the time the problem was presented. Where a choice has been required between two reasonable courses, the person whose wrong forced the choice cannot complain that one rather than the other was chosen. The rule of mitigation of damages may not be evoked by a contract breaker as a basis for critical examination of the conduct of the injured party, or merely for the purpose of showing that the injured person might have taken steps which seemed wiser or would have been . . . to the defaulter. One is not obligated to exalt the interest of the defaulter to this own detriment."

Of course, the issue under this principle of law is for the jury. It should be noted that appellants are not urging that appellee could have gone out and negotiated for a 7-day availability of the product of Warners, Universal and Paramount. In fact, the testimony was exactly to the

contrary. Appellants are urging that under the principle of mitigation of damages, although they had deprived the appellee of the product of Loew's and 20th by reason of the conspiracy, and although with that product appellee would have suffered less loss than it did appellee was obligated as to Warners, Universal and Paramount to (a) determine which pictures he could bid on; (b) determine what bids were likely to obtain a successful result; (c) determine that in fact the bids would be accurately and fairly appraised by these companies and (d) that they would in fact award the picture or a group of pictures to appellee; and (e) the pictures would be awarded at prices which would have made it possible for appellee to play them profitably; (f) that in fact the pictures would have been delivered in accordance with the offer and acceptance.

It should be noted that each of the companies, Paramount, Universal and Warners, asserted the privilege of rejecting all bids; that there was absolutely no assurance whatsoever that any bid would even be accepted, even if it was the highest bid. Of course, the appellees' obtaining of any pictures would turn not only upon what its own bid would be and the evaluation of that bid by the distributor, but upon what the other bidders would do. Thus, there was complete uncertainty in this sense and appellees' action in seeking negotiation with the distributors for an availability which in good faith he believed was sound and reasonable and which from the point of view of the distributors interest was sound and reasonable, was in full compliance with any rule or any mitigation of damages. In any event, this was an issue for the jury and the jury having determined in appellee's favor it is submitted that that finding should not be set aside.

V.

There Was Neither Reversible Error nor Prejudice to the Appellants in the Court's Addition of the Language "in the Absence of a Conspiracy" to Appellants' Proposed Instructions 26, 31a, 34, 31 and 11.

Appellants argue that when the court added the language "in the absence of a conspiracy" to appellants' proposed instructions 11, 26, 31, 31a and 34, that it committed error.

An examination of these proposed instructions as they were submitted, and the position taken by counsel, shows that:

1. As to each of these instructions, except No. 11, (a) appellants stated no grounds for objections to the modifications or stated insufficient grounds for such objections and (b) appellants violated this Court's Rule 18(2) in failing to set forth in their brief the specific grounds of the objections urged at the trial.

2. Each of these instructions as originally proposed by appellants were either erroneous or ambiguous.

3. If the modifications adopted did not resolve the ambiguity created by appellants' form of instruction, that the ambiguity was effectively resolved by the express language of the remaining instructions and by the express finding through a special interrogatory that each appellant participated in the conspiracy.

INSTRUCTION 11. Defendant's proposed Instruction 11, as originally proposed, read as follows:

"Defendants' Instruction No. 11.

"The plaintiff in this case, as an exhibitor of motion pictures, did not have the right to compel any

of the defendant motion picture distributors to grant it a preferred run, or preference in licensing product, or, in fact, to license it any motion pictures. There is nothing illegal in the mere fact that plaintiff could not get the pictures it wanted on the particular run that it wanted." [R. 126.]

Objections to defendants' Instruction 11 were considered at a full hearing by the court. The colloquy concerning this instruction reads as follows:

"The Court: Now comes No. 11. Mr. Corinblit says that if we should insert after the word 'right' on line 4, 'did not have a right as a matter of law' there is no objection as to that.

Mr. Mitchell: No, that is all right.

Mr. Corinblit: Yes, that is right.

The Court: And then he says, in the second sentence: 'In the absence of the conspiracy there is nothing illegal.'

Mr. Mitchell: Let's put that at the beginning of the sentence: 'In the absence of a conspiracy there is nothing illegal.'

Mr. Corinblit: Yes, that is the proposition.

The Court: We will put that in front and with those modifications it will be given. Your next objection is to Instruction 15."

Thus, from the record it is clear that appellants approved the modification and certainly stated no grounds for objection, moreover appellants failed to comply with this court's Rule 18(2), which requires that when the error alleged is to the charge of the court the specification shall set out the part referred to ". . . together with the grounds of the objection alleged at the trial."

Of course the reason appellants did not set out these objections to Instruction No. 11 was because counsel for

appellant Loew's approved the modification by the court. Counsel for appellants Fox West Coast and 20th Century-Fox were silent.

INSTRUCTION 31a.

Instruction 31a, as proposed by appellants, read as follows:

“Defendants’ Instruction No. 31A.

“You are instructed, as a matter of law, that the licensing of 7 day availabilities to theatres in the principal suburban cities of the Los Angeles metropolitan area, such as Inglewood, Huntington Park, Pasadena and Glendale, and a refusal of a separate 7 day availability to theatres in less important suburban communities adjacent to those cities is reasonable. Such practice on the part of any or all of the distributor defendants does not furnish any basis for an inference of conspiracy.” [R. 378.]

The discussion of this instruction occurs at page 2628 of the record. As that record shows, neither counsel for appellants Loew's nor counsel for appellants Fox West Coast and 20th Century-Fox made a single statement of objection to the modification of instruction 31a. Again, the appellants have failed to comply with this court's Rule 18(2) by failing to set forth the “grounds of the objections” urged at the trial because in fact no grounds were stated.

INSTRUCTION 34.

Appellants proposed Instruction No. 34 reads as follows:

“Defendants’ Instruction No. 34.

“(In lieu of Instruction No. 34, filed July 5, 1956.) You are instructed that each defendant distributor had the right, acting individually, to determine how many 7-day runs it would license in the Inglewood-Westchester area regardless of whether or not the-



atres in that area were in ‘substantial competition.’ You are further instructed that, having determined how many 7-day runs to offer in that area, each defendant had the right, acting individually, to offer them by bidding or negotiating among theatres in that area, regardless of whether the theatres were in ‘substantial competition.’ The defendant distributors are not required to license a 7-day run to every theatre which was not in ‘substantial competition’ with some other theatre or theatres.” [R. 383.]

The discussion of this instruction appears at R. 2630. The language of that colloquy is as follows:

“The Court: I will refuse 33-C. The next one is 34. This is a substituted 34. I think that is all right if we insert our stock clause, ‘in the absence of a conspiracy.’

Mr. Mitchell: Where do you want to put that, your Honor?

The Court: ‘You are instructed that each defendant distributor in the absence of a conspiracy . . .’

Mr. Mitchell: We have got ‘acting individually,’ in there. Do you want both?” [R. 3446.]

“The Court: Well, we will strike out ‘acting individually,’ and with that modification I will give 34. Now we have 34-A.”

Again there was obviously no express objection by counsel—rather tacit approval—certainly no specific grounds were stated for objection. Again this Court’s Rule 18(d) was ignored by appellants in their brief.

Appellants make reference to the trial court’s ruling that it would be admitted that all parties had objected to the modifications. This was not intended, of course, and could not operate to remove from appellants the burden of stating the *grounds* upon which their objections were based (citation).

INSTRUCTION 26.

As proposed by appellant, Instruction 26 read as follows [R. 71]:

“Defendants’ Instruction No. 26.

“Subsidiaries of Twentieth Century-Fox owned and operated the Loyola, Academy, Fifth Avenue and Fox Inglewood from August of 1950 through September of 1951.

“I instruct you that Twentieth Century-Fox in the exercise of its own business judgment, had the right to exhibit all of its motion pictures in the Loyola, Academy, Fifth Avenue and Fox Inglewood Theatres and any other theatres owned and operated by it in such manner and upon such terms and subject to such conditions as may have been satisfactory to it. I instruct you that there was no obligation on the part of Twentieth Century-Fox to offer its pictures to the Paradise Theatre and no inference of conspiracy may be drawn from the fact that it did not do so.” [R. 141.]

The discussion of this instruction appears at R. 2604-2606. That discussion reads as follows:

“Your next objection is to 26. I don’t see anything wrong with 26.

Mr. Corinblit: Just a minute, your Honor.

The Court: You have got an argument here. I have read your argument.

Mr. Corinblit: Well, your Honor, if you would add—I think we could cover it, that in the absence of conspiracy, your Honor—

The Court: All right.

Mr. Johnston: Your Honor, *you have covered the question of conspiracy in every other instruction proposed by the plaintiff here.* This is the precise instruction with maybe one or two changes to fit this

case as the court gave in the Lynch or James case. We argued that matter out at length in that case.

Mr. Corinblit: Your Honor, on that point—

The Court: I might have been wrong in the Lynch case.

Mr. Johnston: I submit your Honor was not wrong.

Mr. Corinblit: This is what the defendants have insisted upon in the plaintiff's instructions. Every place where we separated a fact from conspiracy, your Honor remembers as we went through them this morning, every place they insisted, you have got to show conspiracy. Now, this is what the defendants are doing themselves. They are separating facts out away from the element of conspiracy. Now, in the absence of conspiracy, perhaps some of these things are permissible. If your Honor would insert, 'I instruct you that in the absence of conspiracy Twentieth Century-Fox could do these things.' Then you have got the instruction correctly stated." [R. 3416.]

"Mr. Johnston: Your Honor, *you have covered fully in other instructions, both requested by the plaintiff and by the defendants, the matter of conspiracy, and to insert that at every phrase—*

The Court: What harm will be done to say, 'I instruct you in the absence of conspiracy.'

Mr. Johnston: Simply that this, standing as it is, is a correct statement of law. There is no question about it.

The Court: I will insert after the word 'instruct,' 'in the absence of a conspiracy.'

Mr. Mitchell: Do you want to put that after the word 'that'?

The Court: 'instruct you that in the absence'—all right, I won't fight with you over the word 'that.'

Mr. Mitchell: It would be a little easier for you to read, I think.

The Court: With that modification, I will give 26. The next objection is to 29.

Mr. Corinblit: Now, your Honor, I am sorry I wasn't fast enough, but on 26 would your Honor look at the last sentence?

The Court: Yes, I looked at it.

Mr. Corinblit: All right. Now, your Honor, in the presence of other facts—

The Court: I can't cover everything in one instruction." [R. 3417.] (Emphasis supplied.)

It should be noted that the only grounds of objection urged by counsel for Fox West Coast and 20th Century-Fox with respect to Instruction 26 were that the matter of conspiracy had been covered in other instructions and need not be covered in connection with this instruction. The importance of this fact lies in the admission by counsel as we will show more comprehensively later, that the issues of conspiracy against the named defendants was made central to the case, and dominated all of the instructions.

Thus the only objection made by appellants at the trial was that the modification of Instruction 26 was superfluous. This ground is of course not urged here and it could not in any event on this record constitute error.

Here again, appellants have failed to comply with this court's Rule 18(2), in that they failed to set forth the grounds urged at the trial for their objection to this instruction, this time obviously because they recognized the insufficiency of the objection at the trial and because they recognized that they were changing their theory of objection for the first time on appeal. Appellants' brief does make reference to a modification raised to appellants' proposed Instruction 27, which instruction is

not embodied in their statement of points on appeal and to which no objection is made in this court. This, of course, does not cure the default with regard to the specific instructions upon which this appeal is based.

Appellants attempt to read their objection made to Instruction 27 back into their objections to Instruction 26 fails for another reason. It is clear from an examination of defendants' proposed instruction 26 that, as proposed, it was an incomplete and ambiguous statute of the law. Thus, it will be noted that Instruction 26 requested the court to state to the jury that 20th Century-Fox in the exercise of its own best judgment had the right to exhibit all of its motion pictures in theatres which it owned in such manner and upon such terms and subject to such conditions, as were satisfactory to it. Standing alone, the instruction is clear error, since if 20th Century Fox *was the participant in a conspiracy* to restrain trade with respect to the exhibition of motion pictures, including its own motion pictures in Inglewood and the Westchester area, then it no longer had such a right. The failure on the part of appellants to include this fact in the instruction precludes them from objecting here since it is established that in order to charge error as to an instruction not given as proposed, it must be correct *as proposed*.

The modification adopted by the Court attempted to clarify the ambiguity of Instruction 26 as proposed by appellant.

At the outset, it should be noted that, literally speaking, the instruction as modified is not an erroneous statement of the law if the original instruction, as proposed by appellants, was not erroneous. Thus, if it was a correct statement of law that 20th Century-Fox, in the exercise of its own best judgment, had the right to exhibit all of its motion pictures in theatres which it owned in such manner and upon such terms and sub-



ject to such conditions as were satisfactory to it, then literally the statement that “in the absence of a conspiracy” 20th Century-Fox had the right, also stated the law correctly. Appellants are required to *infer* from the modified instruction that the Court was instructing the jury that in the absence of a conspiracy, whether or not 20th Century-Fox participated in it, 20th Century-Fox *did not have that right*. Whether or not such an inference was possible from the literal language of the instruction *standing alone*, it is submitted that it was *impossible* when all of the instructions are construed as a whole and when the special interrogatory answered by the jury is examined.

In this action, the Court, for the benefit of the defendants, proposed that special interrogatories be submitted to the jury covering conspiracy as to first run Los Angeles and as to 7-day availability. The interrogatories were prepared by the defendants and submitted to the jury. The extent to which the jury considered these interrogatories is indicated by the fact that they found that there was no conspiracy on the first run and that three out of seven groups of defendants participated in the conspiracy with respect to the 7-day run. Their finding as to participation is express. Thus, the jury had before it an interrogatory which included the names of all of the defendants.

The jury struck out the names of certain defendants only and thus made the finding as to the appellants' express [R. 2846]. In the face of the jury's action, it seems incredible to argue that the jury did not know that it could not find against appellants unless it found that each appellant participated in the conspiracy charged.

The instructions support this proposition even more completely. Thus, the Court told the jury that it “must not pick out one instruction and base (it) conclusion upon one instruction, but (it) must consider all the

instructions, and consider each instruction in relation to the other” [R. 2757]. The Court stated that each defendant was entitled to individual consideration [R. 2763] and that the extent of the conspiracy could not be established as to any defendant by the acts or statements of its alleged co-conspirators in its absence [R. 2764]. The Court required that each defendant’s connection with the alleged conspiracy be established by independent proof [R. 2764]. The jury was told that the plaintiff was required to show wrongdoing on the part of each defendant against whom it sought damages [R. 2765] and that no defendant was to be prejudiced because it had been named as a defendant with others in the case [R. 2765].

Further the Court instructed the jury that the fundamental question was whether defendants conspired with each other during the damage period [R. 2772] and that the conspiracy that would be material in the case at bar would be an agreement among the defendants or some of them to deprive the Paradise Theatre of prior runs to which it would have otherwise been licensed [R. 2773].

The court instructed that to show conspiracy a person must combine with someone else to effect its object by means agreed upon [R. 2773].

With respect to the defense of independent action, the instructions were replete with references making that proposition clear. Thus, the jury was instructed that “each defendant had the right, acting independently, to refuse Los Angeles first run to the Paradise and to refuse 7-day availability to the Paradise except by bidding, regardless of whether the theatres required to bid were in substantial competition” [R. 2772]. The jury was told “that separate independent action by each defendant is not illegal under the antitrust laws. Independent action of each distributor would not form the basis of violation; there must be an element of a conspiracy” [R. 2776].

This proposition was repeated again when the Court instructed the jury that if they found “that the decision of the distributor defendants, during the period with respect to license of motion pictures to the Paradise Theatre, was reached independently and in the exercise of its own business judgment, then such licensing could not form the basis of a conspiracy” [R. 2776]. The jury was instructed that it was to consider the reasonableness of the defendant’s conduct [R. 2778]; that if identical action by any of the defendants was the result of independent action, then a conspiracy could not be found [R. 2778]. The court instructed that similarity of business practices which resulted from common business solutions to identical problems would not support a conclusion as to conspiracy and that even if the defendants knew what the other defendant was doing with respect to certain business practices, that they still had freedom of action [R. 2779].

Other instructions of the same character appear at R. 2781 through R. 2789.

In the face of these instructions, the ambiguity, if there was one, in the instruction objected to by appellants was certainly harmless.

This same analysis is applicable to each of the five instructions to which objection is made. With respect to each of them, the instructions as proposed were either erroneous or ambiguous since they were not limited by the fact that the abstract rights referred to in each of these instructions were qualified by the obligations under the Sherman Act. (Citation.)

*Flintkote Co. v. Lysfjord*, ..... F. 2d ..... No. 15005;

*Lorain Journal Co. v. United States*, 342 U. S. 143 (1951).

Each of these instructions, as modified, examined literally (as the appellants make their literal objection) correctly stated the law. If ambiguity was created, the special interrogatory and the other instructions clarified the ambiguity and made it harmless.

A decision applicable here is *United States v. International Fur Workers Union* (C. A. 2, 1938), 100 F. 2d 547. In that case, the Fur Workers Union and others were indicted under the Sherman Antitrust Act. The charge was a conspiracy to restrain and monopolize interstate commerce in fancy fur skins. After a trial, defendants were found guilty. One of the grounds urged on appeal was error with respect to the use of the phrase, "an unlawful plan." The instruction to the jury read as follows:

"There is no doubt that a labor union has the right to say that it wants to have this condition or the other, and the labor union at times, as a condition to putting men in your plant may say you have to deposit money; that is easily conceivable; but the question here is whether or not this was part and parcel of the plan, of the offenses charged in the indictment, not that they may do a particular thing in and of itself which may be perfectly lawful. The question is whether or not that thing alone without other things, contributed and were part and parcel of an unlawful plan."

Appellants argued that the court's reference "to an unlawful plan" left the jury without guidance as to what plan the court had in mind. The court held that "it must have been obvious to the jury that (the trial court) was referring to the conspiracy as charged in the indictment and as proved upon the trial."

The only decision cited by appellants in support of their argument is this court's decision in *Flintkote Co. v. Lysfjord*, ..... F. 2d ....., No. 15005, filed March 29,

1957. The facts in that case are clearly distinguishable from the facts here.

In that case, the plaintiff had originally sued the manufacturer and a group of distributors for damages suffered as a result of the violation of the antitrust laws. Prior to trial, the distributors were dismissed. Instructions to the jury, which had been prepared on the basis of the presence of numerous defendants, were to have been modified so as to show clearly that only one defendant remained in the case. That was not done. Moreover, the manufacturer's sole defense was that while his distributors may have conspired, he was not a participant thereof.

Out of the four references to questionable instructions made by the court in its decision in the *Flintkote* case, three of them turned upon the fact that plural "defendants" were used when in fact there was only one defendant in the case. The other reference found it to be inaccurate for the trial court to state to the jury that while a seller may select his own customers "under the antitrust laws, it could not do so if there has been a conspiracy."

In the *Flintkote* case, this court said, as to this critical language, "Without interpretation this is an inaccurate expression of the law. It permits a recovery against a defendant who refuses to deal 'if there has been a conspiracy,' irrespective whether or not the defendant then sought to be held participated therein." Plaintiffs can only urge that it might be *inferred* that because of the first sentence (de-emphasized in App. Br.) there was implicitly added to the last sentence the words, "in which *Flintkote* participated." As we have pointed out above, it is the *appellants* who require the inference in this case in order to convert an instruction which is literally correct into an erroneous one. This is exactly contrary to the facts in the *Flintkote* case. In the case at bar, the



jury was never instructed that the appellants lost any rights because a conspiracy existed.

The strongest argument to be made with respect to the modification of the instructions objected to is that an ambiguity existed. But, as we have shown, the overwhelming impact of the instructions, together with the special interrogatory, make it clear that the jury rendered an accurate verdict.

### Conclusion.

This court recently pointed out that “the private anti-trust action is an important and effective method of combatting unlawful and destructive business enterprises. The private suitor complements the government in enforcing the antitrust laws. The treble damage provision was designed to foster and stimulate the interest of private persons in maintaining a free and competitive economy. Its efficacy should not be weakened by judicial construction.” (*Flintkote Co. v. Lysfjord*, ..... F. 2d ....., No. 15005, dated March 29, 1957.)

In the trial court, appellee was obliged to produce evidence which convinced the jury that the appellants had engaged in a combination and conspiracy to unreasonably restrain and monopolize the exhibition of motion pictures on the 7-day availability, and that the conspiracy injured the plaintiff in his business. The jury found that the proof was ample to establish the conspiracy and to establish the injury to the plaintiff. The trial court found to the same effect.

This proof of antitrust violation is not overcome by protestations that the motion picture industry has long been aware of the impact of the antitrust laws upon the

licensing of motion pictures. The record of these appellants for antitrust violation is too blatant to suppose that conspiracy and discrimination against independent theatres has not been an acceptable business tool for domination of the motion picture industry by these appellants.

In this case, express testimony as to participation in these antitrust violations certainly precludes the application to these appellants of any rule of proof which would give them a preference in the eyes of the law. In essence, appellants' brief seeks this preference.

The sum and substance of appellants' arguments are: that their violations of the antitrust laws are to be tested by purported reasonableness of their *explanations* and *excuses* for their action, and not by the *proof* of conspiracy and unreasonableness of their actions. Appellants' brief gives lip service to the substantial evidence rule, ignores the testimony and the implicit inferences from the testimony, ignores appellee's evidence, and erects rationalizations by discredited witnesses and weak speculative arguments from distorted statistics into an absolute defense.

In essence, appellants' brief makes the argument which the appellant in the *Flintkote* case, *supra*, made, *i.e.*, the argument that "despite my knowledge of a conspiracy which existed, which I knew to be unlawful, I am innocent and cannot be held liable, because I say I exercised my business judgment, and I can refuse to sell to anyone, and that is lawful, no matter what the circumstances may be." This court answered this argument, as it must be answered here, when it said, "but it is not for the seller to finally decide that it was for a good business reason, or no reason, that he refused to deal. That deci-

sion, placed in its proper perspective and circumstance and facts known to the seller, must be judged by the trier of facts, to determine if it was an innocent and lawful exercise of the seller's private right or an act which showed knowing participation in an unlawful conspiracy.

Were it otherwise, there could never be a civil judgment nor any criminal conviction against any manufacturer of products flowing in interstate commerce."

The judgment below should be affirmed.

Respectfully submitted,

WELLER & CORINBLIT,

ELWOOD KENDRICK,

JOSEPH ALIOTO,

By JACK CORINBLIT,

*Attorneys for Appellee.*

No. 15427

IN THE

# United States Court of Appeals

FOR THE NINTH CIRCUIT

---

UNITED STATES OF AMERICA,

*Appellee,*

*vs.*

CHARLES E. BLACKFORD,

*Appellant.*

---

## BRIEF OF APPELLEE.

---

LAUGHLIN E. WATERS,  
*United States Attorney,*

LOUIS LEE ABBOTT,  
*Assistant United States Attorney,  
Chief, Criminal Division,*

HARRY D. STEWARD,  
*Assistant United States Attorney,*

HOWARD R. HARRIS,  
*Assistant United States Attorney,  
600 Federal Building,  
Los Angeles 12, California,  
Attorneys for Appellee.*

**FILED**

MAR 30 1957

PAUL P. O'BRIEN, CLERK





## TOPICAL INDEX

PAGE

### I.

Statement of the case..... 1

### II.

Issues ..... 5

### III.

Argument ..... 6

A. Customs officers are entitled to search persons entering the United States for merchandise and for contraband..... 6

B. The search of appellant was reasonable under the circumstances ..... 9

1. The facts of the case clearly showed that the search was reasonable under the circumstances..... 9

2. The interests of society requires such searches under these circumstances ..... 10

3. Rochin v. California can be validly distinguished..... 12

4. Customs inspectors have the power and duty to make such searches under these circumstances whether or not resistance is offered..... 17

C. It was the duty of the customs officers, having custody of appellant, to take all reasonable steps to protect the health and safety of appellant as well as all other prisoners..... 20

### IV.

Conclusion ..... 20

## TABLE OF AUTHORITIES CITED

CASES	PAGE
Boyd v. United States, 116 U. S. 616.....	7
Breithaupt v. Abram (Oct. term, 1956), decided Feb. 25, 1957....	10, 15, 16
Carroll v. United States, 267 U. S. 132.....	7, 10
City of Tulsa v. Sisler, 285 P. 2d 422.....	20
Go-Bart Importing Company v. United States, 282 U. S. 344....	11
Keck v. United States, 172 U. S. 434.....	6
Logan v. United States, 144 U. S. 263.....	20
People v. Cahan, 44 Cal. 2d 434.....	15
People v. Haeussler, 41 Cal. 2d 252, cert. den. 347 U. S. 931....	15
People v. Woods, 132 Cal. App. 2d 515, 293 P. 2d 901.....	14, 15, 18, 19
Rochin v. California, 342 U. S. 165.....	12, 14, 15, 17, 18
Spicer v. Williamson, 191 N. C. 483, 132 S. E. 291, 44 A. L. R. 1280 .....	20
United States v. Baray (1953), S. D. Tex., No. 14907.....	12
United States v. Hardy (1956), S. D. Cal., No. 25948-SD.....	12
United States v. Landau, 82 F. 2d 285.....	7
United States v. Lieberknecht (1953), S. D. Tex., No. 13965....	12
United States v. Perez (1957), S. D. Cal., No. 26350-SD.....	12
United States v. Pierce (1956), S. D. Tex., No. 17312.....	12
United States v. Willis, 85 Fed. Supp. 745.....	17
United States v. Yee Ngee How, 105 F. Supp. 517.....	9

### REGULATIONS AND STATUTES

19 Code of Federal Regulations, Sec. 10.19(a).....	6
19 Code of Federal Regulations, Sec. 10.19(b).....	6
19 Code of Federal Regulations, Sec. 21.17.....	6
Act of July 31, 1789 (1 Stat. 43).....	6
United States Code, Title 18, Sec. 111.....	19

	PAGE
United States Code, Title 19, Sec. 482.....	8
United States Code, Title 19, Sec. 1461.....	6
United States Code, Title 19, Sec. 1484.....	6
United States Code, Title 19, Sec. 1485.....	6
United States Code, Title 19, Sec. 1498.....	6
United States Code, Title 19, Sec. 1581.....	8
United States Code, Title 19, Sec. 1582 .....	8, 9

#### TEXTBOOK

Voltaire, <i>Candide</i> (1759), Chap. XI, "The Old Woman's Story" (Modern Library Ed., pp. 41-42).....	11
--	----



No. 15427

IN THE

# United States Court of Appeals

FOR THE NINTH CIRCUIT

---

UNITED STATES OF AMERICA,

*Appellee,*

*vs.*

CHARLES E. BLACKFORD,

*Appellant.*

---

## BRIEF OF APPELLEE.

---

### I.

#### STATEMENT OF THE CASE.

We do not disagree with the facts of the case as stated by Appellant (App. Br. p. 3). However, we feel that a more complete statement is necessary for the proper presentation of the case. The following facts are substantially those which are stated in the findings of the trial Court. [Clk. Tr. pp. 39-44.]

On July 31, 1956, at approximately 9:45 p.m. Appellant entered the United States from Mexico at the San Ysidro port of entry, San Ysidro, California. Appellant approached the Customs Inspector on duty who was inspecting pedestrian traffic, Customs Inspector Herbert S. Summerhill. Inspector Summerhill asked the Appellant if he had acquired any article in Mexico. The Appellant stated,



“No.” Inspector Summerhill then asked the Appellant to come into the Customs building for an examination and personal search. [Clk. Tr. p. 21.]

After the Appellant and Inspector Summerhill entered the building, Appellant took off his coat. Inspector Summerhill at that time noticed numerous puncture marks in the veins of the arms of the Appellant. Inspector Summerhill asked the Appellant if he was addicted to narcotics. The Appellant replied that he was not addicted at that time although he had used narcotics in the past. The Appellant stated that he was only “chipping” but that he was not “strung out.” In the slang of narcotics users, “chipping” means that a person uses narcotics occasionally and is not addicted. The phrase “strung out” means that a person is addicted. At that time the defendant also stated that he had recently been released from San Quentin following a conviction for possession of marihuana and was still on parole. [Clk. Tr. pp. 21-22.]

The Appellant was ordered to remove his clothing. No contraband was found in the clothing or on his person at that time. Inspector Summerhill and Inspector Eaton, who was also present during the search, noticed a considerable amount of a light colored grease around the anal opening of the Appellant. The Appellant at this time denied that he had any narcotics concealed in his rectum. [Clk. Tr. p. 22.]

The defendant was further questioned by Inspector Summerhill. The Appellant then stated that he had about a “spoon” of heroin which was enclosed in a rubber contraceptive in his rectum. A spoon of heroin is approximately a measured tablespoon. The Appellant, at Inspector Summerhill’s suggestion, attempted unsuccessfully to eject

the heroin and to remove it with fingers at that time. Inspector Summerhill asked Blackford if he wanted to be taken to a doctor who would help remove the heroin. Blackford stated that it would be all right with him. The defendant was put under arrest at that time and was handcuffed. [Clk. Tr. pp. 22-23.]

At approximately 10:30 p.m., United States Customs Agent Girard C. Polite arrived at the Customs building at San Ysidro. Customs Agent Polite questioned the Appellant further, and the Appellant again tried to eject the heroin. Agent Polite took Appellant Blackford to the San Diego County Jail, arriving at the County Jail at approximately midnight. [Clk. Tr. p. 24.]

At approximately 1:30 a.m., August 1, 1956, Dr. Harry W. Depew arrived at the County Jail. Dr. Depew is a physician licensed to practice medicine in the State of California. Dr. Depew told the Appellant that he intended to examine the Appellant's rectum. The Appellant at this time stated that he did not have any narcotics in his rectum. The Appellant asked if he could object to the examination. Agent Polite said that the Appellant could object if he wished; however, the examination was going to be made, in view of Appellant's previous statement that he had heroin in his rectum. The Appellant lowered his own pants and shorts. Dr. Depew examined the Appellant by inserting his finger into the Appellant's rectum, the finger being enclosed in a rubber glove, the glove being lubricated with some petroleum jelly. The Appellant did not cooperate, would not bend over, and would not hold still. Dr. Depew was able to insert his finger into the Appellant's rectum and felt some firm object in the rectum; however, he was unable to remove the object. [Clk. Tr. pp. 25, 27, 28.]

Agent Polite took Appellant Blackford to the United States Naval Hospital, San Diego, California, where they arrived at approximately 2:30 a.m. On arrival at the United States Naval Hospital, the Appellant was taken to the examination room. He was asked to lower his pants but refused to do so. Agent Polite attempted to lower the Appellant's pants but was pushed away by the Appellant. Two hospital corpsmen, George R. Hogabaum and Don W. H. Regan, held the Appellant's arms while Agent Polite lowered the Appellant's pants and shorts. The hospital corpsmen, still holding the defendant's arms behind him, forced the Appellant to bend over.

Dr. Eugene B. Gregory, a qualified physician and resident doctor at the United States Naval Hospital, made a rectal examination of the Appellant with his finger in the same manner as had Dr. Depew. The Appellant still was being held during this examination. Dr. Gregory felt some foreign object in the Appellant's rectum but was unable to remove it. The Appellant was released by the hospital corpsmen. The Appellant was asked to get on an examination table and assume a knee-chest (kneeling) position. The Appellant got up on the table by himself. A corpsmen pushed his head down in order to get his chest close to the table, but the Appellant was not otherwise held while he was on the table. [Rep. Tr. pp. 41, 66.]

At this time Dr. Gregory, using an anoscope and a forceps, attempted to remove the foreign object from the defendant's rectum. A portion of the contraceptive was broken, during this attempt. Dr. Gregory was unable to remove the object. [Clk. Tr. pp. 25-26; Rep. Tr. pp. 39-42, 65-66.]

After the contraceptive was broken the Appellant exhibited some alarm and attempted to eject the object by himself but was unable to do so. The Appellant was given a number of soapy water enemas under the direction of Dr. Gregory. Appellant finally succeeded in ejecting the object. The object consisted of a whitish powder, contained in two rubber contraceptives, one inside the other. The outer contraceptive had been broken. The whitish powder was heroin, weight, one ounce, 333 grains. [Clk. Tr. pp. 26-27, 38; Rep. Tr. pp. 42-43, 66-67.]

## II. ISSUES.

The sole issue in this case is whether the search was reasonable.

The trial court found that Appellant consented to certain parts of the search—the search at the border and the ultimate removal of the heroin—and did not consent to other parts of the search—the search at the county jail and the search at the U. S. Naval Hospital up to the time that the outer container broke. [Clk. Tr. pp. 40-43.]

The evidence presented by the government showed that the Appellant exhibited some alarm after the outer container was broken and that he did consent to the subsequent action of the doctor and the medical orderly in removing the heroin [Clk. Tr. p. 43]; although the Appellant testified to the contrary. [Rep. Tr. p. 62.]

We believe the facts speak for themselves. It is the government's position the officers were empowered to make the search under the circumstances of the case without Appellant's consent.

III.  
ARGUMENT.

A. Customs Officers Are Entitled to Search Persons Entering the United States for Merchandise and for Contraband.

All merchandise that is brought into the United States from a foreign country must be "entered" (19 U. S. C. 1484, 1498). Part of the "entry" consists of a "declaration" to the effect that all papers submitted as part of the entry are true (19 U. S. C. 1485). Oral declarations are permitted in certain instances (19 C. F. R. 10.19(b); 19 C. F. R. 21.17). All merchandise and baggage which is brought into the United States from a contiguous country must be presented to a customs officer for inspection (19 U. S. C. 1461); and all articles brought into the United States by any individual must be declared to a customs officer. (19 C. F. R. 10.19(a).)

In order to enforce the provisions of law pertaining to inspection and declaration of merchandise and to prevent the illegal importation of narcotics and other contraband, customs officers are permitted to search vessels, vehicles and persons entering the country for undeclared merchandise, narcotics and other contraband.

The history of tariff laws in the common law system goes back to the 1600s in England. The case of *Keck v. United States* (1899), 172 U. S. 434, 446-456, contains a short history of the early English and American tariff laws. The first statute passed by Congress to regulate the collection of duties (Act of July 31, 1789 (1 Stat. at Large 43)), authorized seizures of goods concealed to avoid tariff duties.



In *Boyd v. United States* (1886), 116 U. S. 616, 623, the Supreme Court pointed out that the Congress which enacted the 1789 Tariff law was the same Congress which proposed for adoption the original amendments to the Constitution.

“. . . it is clear that the members of that body did not regard searches and seizures of this kind as ‘unreasonable’ and they are not embraced within the prohibition of the amendment.” (116 U. S. 623.)

In *Carroll v. United States*, 267 U. S. 132, the Supreme Court stated that,

“persons who enter the United States may be searched without the necessity of probable cause. Travelers may be so stopped in crossing an international boundary because of national self protection reasonably requiring one entering the country to identify himself as entitled to come in, and his belongings as effects which may be lawfully brought in.” (267 U. S. 154.)

In *United States v. Landau* (2d Cir., 1936), 82 F. 2d 285, a case involving a search of baggage of a person returning to the United States from overseas at the customs house, the Second Circuit Court of Appeals stated:

“As early as 1799, the baggage of one entering the country was subject to inspection (1 Stat. 662). The necessity of enforcing the customs laws has always restricted the rights of privacy of those engaged in crossing the international boundary. See *Carroll v. United States*, 267 U. S. 132, 154, 45 S. Ct. 280, 69 L. Ed. 543, 39 A. L. R. 790. Neither a warrant nor an arrest is needed to authorize a search in these circumstances. In the instant case, there was no disturbance of the Appellant, his resi-

dence, or his effects after a completed entry. It was to these evils that the Fourth Amendment was directed.”

The power of customs officials to make searches of persons coming into the country has three sources of statutory authority. The material portions of those statutes are quoted below:

Title 19, U. S. C., Sec. 1581:

“(a) Any officer of the customs may at any time go on board of any vessel or vehicle at any place in the United States \* \* \* and examine, inspect, and search the vessel or vehicle and every part thereof and any person, trunk, package, or cargo on board, and to this end may hail and stop such vessel or vehicle, and use all necessary force to compel compliance.”

Title 19, U. S. C., Sec. 1582:

“The Secretary of the Treasury may prescribe regulations for the search of persons and baggage and he is authorized to employ female inspectors for the examination and search of persons of their own sex; and all persons coming into the United States from foreign countries shall be liable to detention and search by authorized officers or agents of the Government under such regulations.”

Title 19, U. S. C., Sec. 482:

“Any of the officers or persons authorized to board or search vessels may stop, search, and examine \* \* \* any vehicle, beast, or person, on which or whom he or they shall suspect there is merchandise which is subject to duty, or shall have been introduced into the United States in any manner contrary to law, \* \* \* and to search any trunk or enve-

lope, wherever found, in which he may have a reasonable cause to suspect there is merchandise which was imported contrary to law: \* \* \*.”

In *United States v. Yee Ngee How* (N. D. Cal., 1952), 105 F. Supp. 517, involving a personal search of a seaman coming off of a vessel, the District Court stated in interpreting these sections that it was the intention of Congress to create a broad authority for custom officials to conduct reasonable searches necessary to the enforcement of custom laws. The special provision in Section 1582, *supra*, relating to employment of females to conduct searches of females, further shows the intent of Congress as to the extent of the search of persons at the border.

## **B. The Search of Appellant Was Reasonable Under the Circumstances.**

### **1. The Facts of the Case Clearly Showed That the Search Was Reasonable Under the Circumstances.**

Inspector Summerhill first became suspicious by reason of Appellant's answers and conduct. He noted the Appellant's arms had numerous puncture marks over the veins. The Appellant used some slang which is common to narcotic users. The Appellant admitted that he had served a two-year penitentiary sentence at San Quentin for a narcotics offense. After the Appellant was stripped, a greasy substance was observed around the anal opening of the Appellant. The Appellant admitted having a "spoon" of heroin concealed in his rectum. The Appellant was arrested at this time. [Clk. Tr. pp. 21-23.]

After the Appellant unsuccessfully attempted to eject the narcotic himself, he was taken to a doctor at the county jail. After Doctor Depew was unsuccessful in

obtaining the narcotic, Agent Polite followed the doctor's advice in taking the Appellant to the United States Naval Hospital. [Clk. Tr. p. 25.]

It was only when the Appellant resisted by force Agent Polite's effort to remove the Appellant's trousers that any force was used upon the Appellant. [Clk. Tr. p. 26.] Appellant was restrained while the doctor made the rectal examination with his hand. [Rep. Tr. p. 65.] Thereafter the Appellant submitted to an examination with an anoscope. [Rep. Tr. pp. 41, 66.] At that time a portion of the contraceptive container broke. Following this occurrence, no further force was used on the Appellant to which the Appellant did not consent. The Appellant was cooperating fully when he was given the enema. [Rep. Tr. pp. 42, 43, 67.]

## 2. The Interests of Society Require Such Searches Under These Circumstances.

The Fourth Amendment prohibition against searches extends only to those searches which are unreasonable (*Carroll v. United States*, 267 U. S. 132). The use of the term "unreasonable" implies a weighing process.

In *Breithaupt v. Abram* (Oct. Term, 1956, Decided Feb. 25, 1957), ..... U. S. ....., which case will be discussed most completely later in this brief, the Court stated the problem as follows:

"As against the right of an individual that his person be held inviolable, even against so slight an intrusion as is involved in applying a blood test of the kind to which millions of Americans submit as a matter of course nearly every day, must be set the interests of society in the scientific determination of intoxication, one of the great causes of the mortal

hazards of the road . . . the individual's right to immunity from such invasion of the body as is involved in a properly safeguarded blood test is far outweighed by the value of its deterrent effect due to public realization that the issue of driving while under the influence of alcohol can often by this method be taken out of the confusion of conflicting contentions."

In the instant case the interests of society in the enforcement of custom laws and in the prevention of narcotics traffic would be weighed against the extent of the invasion of the privacy of the defendant under the circumstances of this case. Reasonableness is not a matter of theory but is a pragmatic question, to be determined in each case in the light of its own circumstances (*Go-Bart Importing Company, v. United States*, 282 U. S. 344, 357).

The concealment of narcotics in body cavities is far from a rare occurrence. There is a reference to the search for concealed valuables in natural body cavities in the novel "Candide" by Voltaire, which was written in 1759. ". . . 'tis a custom established from time immemorial among the civilized nations who roam the seas. . . ." (Chap. XI, "The Old Woman's Story," Modern Library Edition, pp. 41-42.) The need for such searches has continued to the present. In the past two and one-half years in twenty per cent of the cases prosecuted involving the smuggling of heroin into San Diego County, the heroin was concealed in natural cavities of the body. [Clk. Tr. p. 32.]



A motion to suppress the evidence was made in the United States District Court in the following unreported cases:

*United States v. Baray* (1953), S. D. Tex., No. 14907;

*United States v. Lieberknecht* (1953), S. D. Tex., No. 13965;

*United States v. Pierce* (1956), S. D. Tex., No. 17312;

*United States v. Hardy* (1956), S. D. Cal., No. 25948-SD;

*United States v. Perez* (1957), S. D. Cal., No. 26350-SD.

In each of the above cases the seizure of narcotics from natural body cavities by customs officers was upheld by the trial court. In some of the cases the trial court did find that the defendant had consented to the search. In no case to our knowledge has a trial court ever granted a motion to suppress the evidence in such circumstances. To quote from the oral opinion of Judge Allred, in *United States v. Baray, supra*,

“I hold it was not unreasonable here, and to say that it was would absolutely tie the hands of law enforcement officials as to importation of heroin and other drugs into this country.”

### 3. *Rochin v. California* Can Be Validly Distinguished.

Appellant relies upon the case of *Rochin v. California* (1952), 342 U. S. 165. The facts as stated by the United States Supreme Court in the *Rochin* case are as follows:

“Having ‘some information that (the petitioner here) was selling narcotics,’ three deputy sheriffs of

the County of Los Angeles, on the morning of July 1, 1949, made for the two-story dwelling house in which Rochin lived with his mother, common-law wife, brothers and sisters. Finding the outside door open, they entered and then forced open the door to Rochin's room on the second floor. Inside they found petitioner sitting partly dressed on the side of the bed upon which his wife was lying. On a 'night stand' beside the bed the deputies spied two capsules. When asked 'Whose stuff is this?' Rochin seized the capsules and put them in his mouth. A struggle ensued, in the course of which the three officers 'jumped upon him' and attempted to extract the capsules. The force they applied proved unavailing against Rochin's resistance. He was handcuffed and taken to a hospital. At the direction of one of the officers a doctor forced an emetic solution through a tube into Rochin's stomach against his will. This 'stomach pumping' produced vomiting. In the vomited matter were found two capsules which proved to contain morphine." (342 U. S. 166.)

The Supreme Court stated:

"We are compelled to conclude that the proceedings by which this conviction was obtained do more than offend some fastidious squeamishness or private sentimentalism about combatting crime too energetically. This is conduct that shocks the conscience. Illegally breaking into the privacy of the petitioner, the struggle to open his mouth and remove what was there, the forcible extraction of his stomach's contents—this course of proceeding by agents of government to obtain evidence is bound to offend even hardened sensibilities. They are methods too close to the rack and the screw to permit of constitutional differentiation." (342 U. S. 172.)

In the instant case, the trial court found that the conduct of the officers and the doctors was not brutal or shocking. [Clk. Tr. p. 44.] Appellant's claim evidently is that any use of force upon his person is necessarily brutal and shocking. (App. Op. Br. p. 6.) Such a conclusion is not warranted. The Court's finding in this matter is a finding based on substantial evidence.

The trial court also found that the search was not painful. Although Appellant complained during the examination that the doctor was hurting him [Rep. Tr. p. 27], under the circumstances the Court was justified in believing that such protestations were feigned.

If there was actual pain involved, it probably resulted from Appellant's resistance. [Rep. Tr. pp. 9-11.] Regardless of whether the rectal examination and the removal of the heroin might be described as uncomfortable [Clk. Tr. p. 29; Rep. Tr. p. 29] or to some degree painful, it certainly cannot be said, as in the *Rochin* case, that the entire course of conduct was so brutal and shocking as to offend the conscience and thus be violative of due process.

In a California case, *People v. Woods*, 132 Cal. App. 2d 515, 293 P. 2d 901, the defendant was arrested for being under the influence of a narcotic. Prior to being taken to the jail he was asked if he had any narcotic on his person, and he stated he did not. He was further advised that it was a felony to bring narcotics into the jail. After the defendant was brought into the jail he was taken to a doctor for examination. The defendant was requested to remove his trousers and bend over, which the defendant did under protest. The doctor upon examination found an object in the defendant's rectum

which turned out to contain heroin. The California District Court of Appeal found that the actions of the officers were not so brutal and shocking that they offended the due process clause under the *Rochin* decision. The Court held that the search was reasonable under the California rule pertaining to searches and seizures. (*People v. Cahan*, 44 Cal. 2d 434.)

The Court in the *Woods* case quoted from *People v. Haeussler* (1953), 41 Cal. 2d 252, 295, cert. den. 347 U. S. 931:

“ . . . ‘The *Rochin* opinion does not rest on the premise that the taking of evidence from the person of the defendant or by entry into his body is the decisive factor. Instead, the entire course of conduct was examined and found to be brutal and shocking’ . . . .”

*Breithaupt v. Abram* (Oct. term 1956, decided Feb. 25, 1957, ..... U. S. ....), is a recent decision by the United States Supreme Court in which Mr. Justice Clark rendered the majority opinion upholding a conviction in the New Mexico State Court of the petitioner for manslaughter. In such case the petitioner was involved in an automobile accident in which he was injured and others were killed. While the petitioner was unconscious, an attending physician withdrew some blood from him by the use of a hypodermic needle. The blood contained about .17% alcohol. This evidence was used to convict petitioner of manslaughter. The Court in distinguishing the *Rochin* case stated:

“We set aside the conviction because such conduct ‘shocked the conscience,’ and was so ‘brutal’ and ‘offensive’ that it did not comport with traditional ideas

of fair play and decency. We therefore found that the conduct was offensive to due process. But we see nothing comparable here to the facts in *Rochin*.

“Basically the distinction rests on the fact that there is nothing ‘brutal’ or ‘offensive’ in the taking of a sample of blood when done, as in this case, under the protective eye of a physician . . . We therefore conclude that a blood test taken by a skilled technician is not such ‘conduct that shocks the conscience,’ *Rochin*, *supra*, at 172, nor such a method of obtaining evidence that it offends a ‘sense of justice,’ *Brown v. Mississippi*, 297 U. S. 278, 285-286 (1936).”

In the instant case the rectal examination and removal of the narcotics was done “under the protective eyes of a physician.” They were performed according to medically approved practices. As with the blood test, such examination and removal is a routine medical practice. [Clk. Tr. pp. 44, 28-29; Rep. Tr. pp. 28, 43.]

In a dissenting opinion, in *Breithaupt v. Abram*, *supra*, Chief Justice Warren stated:

“We should, in my opinion, hold that due process means at least that law-enforcement officers in their efforts to obtain evidence from persons suspected of crime must stop short of bruising the body, breaking skin, puncturing tissue or extracting body fluids, . . .”

Thus, even measured by the standards of the minority opinion of Chief Justice Warren, the search in the instant case does not violate due process.

In the instant case Appellant was carrying the heroin in his rectum as he would carry it in his pocket. Appel-



lant's use of his body cavity as a place of concealment was a wilfully and carefully conceived plan to smuggle the narcotics into the country. The heroin was to be removed from Appellant's rectum and sold on the illegal narcotics market in this country. Two ounces of heroin is a large amount of heroin; it is a commercial amount—heroin to be peddled in the United States. Its cost in Mexico was approximately \$800.00 and it could be sold for as much as \$25,000.00 to \$30,000.00 in the United States. [Clk. Tr. p. 31.] This was not the situation in the *Rochin* case, *supra*, nor in the case of *United States v. Willis*, 85 Fed. Supp. 745, a case similiar to the *Rochin* case. In the latter cases each of the defendants attempted to destroy a small quantity of narcotics by swallowing it.

To state that a smuggler's body cavity is immune from search would be to create a "diplomatic pouch" for narcotics smugglers and to license the smuggling of narcotics into the country. The foregoing statement is not made lightly by reason of the fact, as previously stated, that in twenty per cent of the smuggling cases prosecuted in San Diego in the two and one-half years prior to the instant case, involved narcotics concealed in body cavities.

**4. Customs Inspectors Have the Power and Duty to Make Such Searches Under These Circumstances Whether or Not Resistance Is Offered.**

Appellant apparently makes no complaint as to his original search by Inspector Summerhill at the border, for the actions and the conduct of the Customs Inspectors were entirely proper and lawful. The original questioning of the Appellant was lawful, the examination of the arms of the Appellant was lawful, the continued question-

ing of the Appellant was lawful, and the personal search of the Appellant was lawful, and the arrest was lawful.

Compare such conduct to the conduct of the officers in the *Rochin* case, *supra*, using the words of the California District Court of Appeal, as quoted in the United States Supreme Court's opinion:

“the officers ‘were guilty of unlawfully breaking into and entering defendant’s room and were guilty of unlawfully assaulting, battering, torturing and falsely imprisoning the defendant at the alleged hospital.’ 101 Cal. App. 2d 140, 143, 225 P. 2d 1, 3.” (342 U. S. 166, 167.)

The examination of Appellant in the county jail was similar to the examination of the defendant in *People v. Woods*, *supra*, 139 Cal. App. 2d 515, 293 P. 2d 901. Appellant was in custody after lawful arrest. Appellant was examined by a physician, Dr. Depew. (It is interesting to note that Dr. Depew also made the examination in the *Woods* case.) Appellant did not consent to the rectal examination. Appellant was not held and no force was used. Certainly, there was no conduct on the part of the officers or the doctor which could be described as brutal or shocking. It is submitted that Agent Polite and Dr. Depew acted properly and lawfully.

Admittedly, force was used upon the Appellant during the course of the rectal examination at the Naval Hospital. The Appellant was held while Dr. Gregory conducted the examination.

Assume, for the purpose of argument, that Appellant had not offered physical resistance at the Naval Hospital. The conduct of the Naval Hospital doctors and the hospital orderlies would have been no different than the conduct of the officers and Dr. Depew at the county jail and no different than what happened in *People v. Woods, supra*. If Appellant had not forcibly resisted, it is submitted the conduct of Agent Polite, Dr. Gregory and the hospital orderlies would have been proper and lawful. If Agent Polite had the power to make the search, then Appellant had no right to resist. In fact, the forceful and intentional resistance and interference with a federal officer while in the course of his official duties is itself a crime. (18 U. S. C. 111.) The illegal resistance of Appellant cannot turn a legal search into an illegal search. This would be making a right of two wrongs.

We may ask the question, where did the conduct of Agent Polite and persons acting at his direction become illegal. At the Customs House? At the County Jail? At the hospital? It is submitted that at all times Agent Polite and the persons acting at his direction acted properly and lawfully, that Agent Polite had the power to search Appellant and the duty to do so, that Appellant's illegal resistance did not turn a legal search into an illegal search.

**C. It Was the Duty of the Customs Officers, Having Custody of Appellant to Take All Reasonable Steps to Protect the Health and Safety of Appellant as Well as All Other Prisoners.**

The United States, having the right to hold a prisoner in custody, has an equal duty to protect him against assault or injury from any quarter. (*Logan v. United States*, 144 U. S. 263.) This includes the duty to provide for the necessary medical attention of prisoners.

*Spicer v. Williamson*, 191 N. C. 483, 132 S. E. 291,  
44 A. L. R. 1280, 1283.

*City of Tulsa v. Sisler* (Okla., 1955), 285 P. 2d  
422.

The narcotics concealed in Appellant's rectum were dangerous to his health and safety. There was danger of obstruction of the rectum and rupture of the container. [Clk. Tr. pp. 43-44, 28, 29; Rep. Tr. pp. 30-31.]

The officers were also under a duty to prevent the introduction of narcotics into the county jail in order to protect the other prisoners. [Clk. Tr. p. 33.]

**IV.  
CONCLUSION.**

In this case Appellant was apprehended by Customs Inspector Summerhill smuggling heroin into the United States in a commercial quantity. He was using his body cavity as a pocket to conceal the heroin. The rectal examinations and removal of the heroin were routine medical practices accomplished by approved medical procedure. It is submitted that Appellant's body cavity, under these

circumstances and the other circumstances of this case, is not immune to search. It is submitted that the conduct of Inspector Summerhill and Agent Polite and the doctors acting at their direction, was proper and lawful.

Appellant in effect said to the United States: Yes, I am bringing heroin into the United States from a foreign country! It is in my possession! I defy you to take it from me! I will resist your efforts if you attempt to do so!

It is submitted that under the facts of this case the Constitution of the United States does not prevent the enforcement of the Customs laws of the United States which prohibits the smuggling of narcotics into the United States.

Respectfully submitted,

LAUGHLIN E. WATERS,

*United States Attorney.*

LOUIS L. ABBOTT,

*Asst. United States Attorney,*

HARRY D. STEWARD,

*Asst. United States Attorney,*

HOWARD R. HARRIS,

*Asst. United States Attorney,*

*Attorneys for Appellee.*



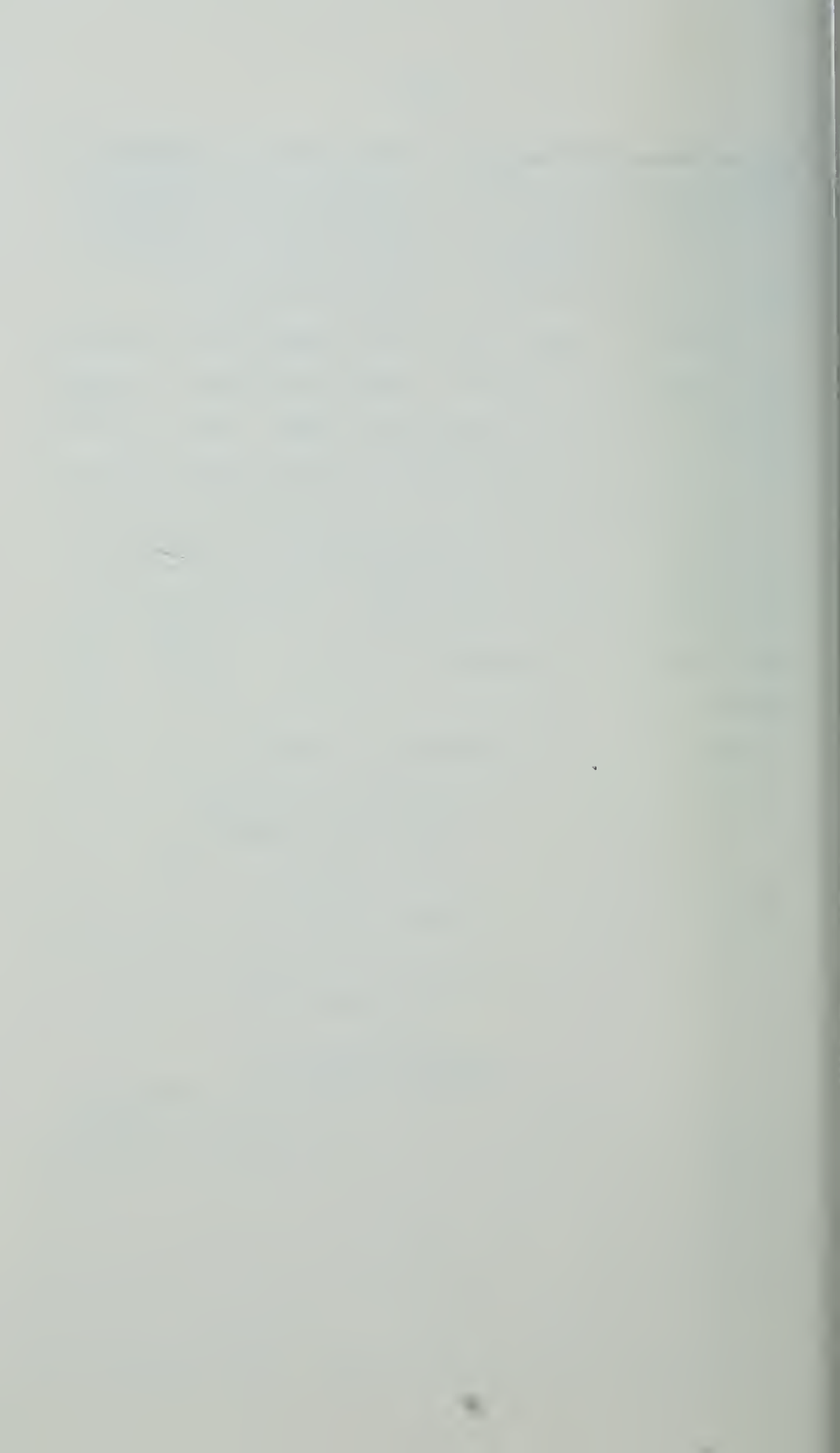

No. 15428

---

---

United States  
Court of Appeals  
for the Ninth Circuit

---

R. H. W. LEATHERS,

Appellant,

vs.

UNITED STATES OF AMERICA,

Appellee.

---

Appellant's Opening Brief

---

Appeal from the United States District Court for the  
District of Oregon

---

RAYMOND M. KELL,  
CLIFFORD B. ALTERMAN,  
Equitable Building,  
Portland, Oregon,  
*Attorneys for Appellant.*

C. E. LUCKEY,  
United States Attorney for the District of Oregon,  
*Attorney for Appellee.*

FILED

JUN 27 1957

PAUL P. O'BRIEN, C



## SUBJECT INDEX

	PAGE
Jurisdictional Statement . . . . .	2
Statutes Involved . . . . .	2
Statement of the Case . . . . .	3
Questions Involved . . . . .	3
Manner in Which Questions Raised . . . . .	4
1. Failure to present prima facie case . . . . .	4
2. Admission evidence . . . . .	4
3. Curtailed cross examination . . . . .	7
4. Improper argument . . . . .	7
Specification of Errors . . . . .	10
Argument . . . . .	17
Summary . . . . .	17
I. Defendant's motion for a directed verdict of acquittal on count one should have been granted . . . . .	18
A. There is no evidence that defendant wilfully evaded Peterson's taxes . . . . .	18
B. When there is no evidence of intent to wilfully evade a tax, there can be no conviction . . . . .	18
II. Peterson's books were improperly admitted and used . . . . .	20
A. There is no testimony to connect defendant with the books and records of Peterson's Sea Foods . . . . .	20
B. The books and records are not evidence against de- fendant . . . . .	20
III. Defendant's impeaching cross examination of Russell A. Peterson to show bias, prejudice, interest and inconsistency was erroneously curtailed . . . . .	22
A. Peterson had an interest in avoiding or reducing his potential tax liability . . . . .	22
B. The evidence shows that Peterson may have had a hope of reducing his tax liability by testifying against defendant . . . . .	22
C. The evidence shows civil litigation between Peterson and defendant . . . . .	22

SUBJECT INDEX—Continued

D. Defendant had a right to place Peterson in his proper setting, to show claims he may have had against defendant, to show bias, and to show beliefs or hopes Peterson may have had for favorable treatment by the government.....	22
IV. The United States attorney's argument deprived defendant of rights guaranteed by the fifth amendment to the constitution.....	28
A. The settlement between Peterson and Leathers, the circumstances of the settlement, the items asserted, the work sheet defendant and his attorney showed government agent, Amos, and any other work sheet used by defendant were provable only by testimony of defendant or his attorney.....	28
B. The United States Attorney, in his closing argument, repeatedly referred to and commented upon the defendant's not producing these documents.....	28
C. A defendant is deprived of due process and his privilege against self incrimination is vitiated if a prosecuting attorney refers to failure to produce evidence provable only by his testimony or the testimony of his attorney.	28
Conclusion.....	34



TABLE OF AUTHORITIES  
CASES

	PAGE
Alvord v. United States (1931) 282 U.S. 687, 51 S. Ct., 218, 75 L. Ed. 624 . . . . .	22, 25
Barnes v. United States (8 Cir., 1925) 8 F.2d 832 . . . . .	28, 31
Bloch v. United States (9 Cir., 1955) 221 F.2d 786; Rehearing Denied 223 F.2d 997 . . . . .	18, 19, 20
Farkas v. United States (6 Cir., 1924) 2 F.2d 644 . . . . .	25
Gordon v. United States (1953) 344 U.S. 414, 73 S. Ct. 369, 97 L. Ed. 447 . . . . .	23, 26
Jones v. United States (5 Cir., 1947) 164 F.2d 398 . . . . .	18, 20
Linden v. United States (3 Cir., 1924) 296 Fed. 104 . . . . .	28, 30
McFarland v. United States (D.C., C.A., 1949) 174 F.2d 538 . . . . .	22, 26
Meeks v. United States (9 Cir., 1947) 163 F.2d 598 . . . . .	22, 26
State v. Swan (1946) 25 Wash. 2d 319, 171 P.2d 222 . . . . .	29, 32
United States v. Beekman (2 Cir., 1946) 155 F.2d 580 . . . . .	22, 26
United States v. Cohen (3 Cir., 1947) 163 F.2d 667 . . . . .	24
United States v. Lindstrom (3 Cir., 1955) 222 F.2d 761 . . . . .	18, 20
Villaroman v. United States (D.C., C.A., 1950) 184 F.2d 261, 21 A.L.R. 2d 1074 . . . . .	23, 27
Yates v. United States (9 Cir., 1955) 227 F.2d 851 . . . . .	29, 32

STATUTES

26 U.S.C. §145(b) (1939 Internal Revenue Code) . . . . .	1, 2, 4, 10, 19, 20
26 U.S.C. §3793(b)(1), (1939 Internal Revenue Code) . . . . .	1, 2
28 U.S.C. §§1291, 1294(1) . . . . .	2



United States  
Court of Appeals  
for the Ninth Circuit

---

R. H. W. LEATHERS, *Appellant*,

vs.

UNITED STATES OF AMERICA, *Appellee*.

---

Appellant's Opening Brief

Appeal from the United States District Court for the  
District of Oregon

---

**APPELLANT'S OPENING BRIEF**

This is an appeal by an accountant, R. H. W. Leathers, from a conviction of a charge of violating 26 U.S.C. §145(b) (1939 Internal Revenue Code), by knowingly filing a false return for one of his clients, Russell A. Peterson, for the year 1946. Mr. Leathers was found not guilty on a second count charging violation of 26 U.S.C. §3793 (b)(1), (1939 Internal Revenue Code), involving the same return. The defendant was sentenced to thirty months imprisonment.

## JURISDICTIONAL STATEMENT

The Jurisdiction of the District Court over the alleged offense is conferred by 26 U.S.C. §145(b) and §3793(b)(1), [Internal Revenue Code of 1939], and of this Court, on appeal, by 28 U.S.C. §§1291, 1294 (1).

## STATUTES INVOLVED

1. 26 U.S.C. §145(b) as of 1947, [as relevant, now 26 U.S.C. §7201] provided:

“\* \* \* and any person who wilfully attempts in any manner to evade or defeat any tax imposed by this chapter or the payment thereof, shall, in addition to other penalties provided by law, be guilty of a felony and, upon conviction thereof, be fined not more than \$10,000, or imprisoned for not more than five years, or both, together with the costs of prosecution.”

2. The relevant portion of the Fifth Amendment to the Constitution is:

“\* \* \* nor shall [any person] be compelled in any criminal case to be a witness against himself, nor be deprived of life, liberty, or property, without due process of law . . .”

## STATEMENT OF THE CASE

### QUESTIONS INVOLVED

1. Did the government present a prima facie case to support its charge that defendant—the accountant—did “wilfully and knowingly attempt to evade a large part of the income tax due and owing by Russell A. Peterson . . . [the taxpayer] for . . . 1946, by filing and causing to be filed . . .” a false return showing Peterson’s net income as \$16,910.55, and tax as \$4,010.25, when the true income was \$56,910.05 and tax was \$28,977.41?

2. Were the books and records of Peterson’s Sea Foods (Exhibits 14, 15 and 16), and the summary sheet prepared by Peterson’s bookkeeper (Exhibit 17) connected to defendant, and did the court erroneously permit extensive use of the books and summary sheets?

3. Did the court so erroneously curtail defendant’s attempt by cross examination of Peterson—the taxpayer—to show a basis for bias, prejudice or interest, and to show inconsistent positions as to deprive defendant of a fair trial?

4. Did the closing argument of the government deprive defendant of rights guaranteed by the Fifth Amendment to the Constitution of the United States?



## MANNER IN WHICH QUESTIONS RAISED

(1) The prosecution did not present a prima facie case of violation of 26 U.S.C. §145 (b) [1939 Code].

This case involves the 1946 tax return of Russell A. Peterson, proprietor of a fish and crab processing plant known as "Peterson's Sea Foods", located on the Oregon Coast in the vicinity of North Bend. (Tr. 58). The defendant—an accountant—prepared Peterson's tax returns, (Tr. 71), and is charged with wilfully falsifying the returns in order to evade Peterson's tax.

The allegation of a false return turns on the reporting of gross receipts. The return shows gross receipts as \$236,555.64. (Ex. 3, Schedule C). The government over objection offered testimony to show gross receipts of \$277,555.64. (Tr. 79, Exs. 14-17).

The testimony is that Leathers signed both his and Peterson's names to the return (Tr. 54), and stamped the return "This return prepared by me from figures furnished by the taxpayer". (Ex. 3).

The government introduced no evidence to show that defendant ever saw, had in his possession, had access to Peterson's Sea Foods' books (Exs. 14-16) or the summary sheets (Ex. 17), or had any basis for a belief that the return was false. This fact is established by examining the testimony of each witness as to the books of Peterson's Sea

Foods and the method employed by defendant to compute the tax.

The witnesses Roswell J. DeMott, Robert A. Leedy, Stanley McDonald, Victor Ferrara, Cecil Tucker, and William C. Weber, Jr., gave no testimony relative to custody, possession, or control of Peterson's books and records or the preparation of the return.

Robert D. Amos, a special agent of the intelligence division of the Internal Revenue Service, (Tr. 48) testified to a conversation with defendant on August 15, 1952 (Tr. 172). Amos testified that Leathers told him that he had prepared the return from a work sheet, which contained figures copied from data furnished him. (Tr. 168). Amos testified that he saw the sheet briefly and noticed erasures on the work sheet, specifically mentioning the net profit item, but had no recollection of any details. (Tr. 168).

Will G. Barrow, Peterson's bookkeeper, testified that he "didn't personally deliver it" (Tr. 78), and "that maybe once or twice I took the abstract over to Mr. Peterson's house and left it there to be picked up." (Tr. 118). He did not testify to either giving Peterson's books to the defendant, or giving the summary sheet to defendant, or to any knowledge of the defendant having the books or summary sheet.

Oran T. Cospers, a long time Revenue Agent (Tr. 156), first met with defendant while investigating Peterson's re-

turns (Tr. 157). This was about February 8, 1952 (Tr. 158). He contacted the defendant in Reedsport, asked for papers relative to Peterson's return, and saw only one slip of paper with no figures on it (Tr. 157). Cosper had several other conferences with defendant at Reedsport and Eugene (Tr. 158). In July 1952 he conferred with defendant in the Eugene office of defendant's attorneys (Tr. 159). At that time Mr. Cosper saw Peterson's returns and some papers "associated" with them (Tr. 159). He did not recall how the papers were "associated" (Tr. 159). Mr. Cosper gave no other testimony relative to the preparation of the return, and gave no testimony that defendant ever had access to Peterson's Sea Foods' books or records.

Russell A. Peterson—the taxpayer—told the defendant to get the information from the company's bookkeeper Barrow (Tr. 132). Peterson gave no information to the defendant (Tr. 132). Peterson had no knowledge of his own of any records which defendant may have had (Tr. 137).

To summarize: Peterson said he told defendant to get figures from Barrow; Barrow said he did not give the books or summary to defendant; government agents Amos and Cosper briefly saw a sheet which Amos testified tallied with the return. But—there is no evidence to show defendant knew the gross receipts were as alleged by the government, and no evidence to show any wilful intent to evade Peterson's taxes. There is no evidence to show Leathers

had any reason to believe the figures on the return were not accurate.

Defendant raised the issue of insufficient evidence by motion for directed verdict of acquittal before resting without putting on a case (Tr. 190-197).

**(2) Admission, relevance and connection to defendant of Peterson's Sea Foods' books.**

The books of Peterson's Sea Foods were Exhibits 14, 15 and 16. Exhibit 17 is a carbon copy of a summary of Peterson's books prepared by his bookkeeper, the witness Will Barrow. (R. 78). The defendant continually, vigorously and unsuccessfully objected to the introduction and use of Exhibit 17 (p. 77, 79, 80, 90-91, 92, 120, 161, 168-169).

The bases of the objections to the introduction into evidence and subsequent use of Exhibits 14-17 were lack of foundation (Tr. 77, 168), as not the best evidence (Tr. 91, 161, 168), failure to connect to the defendant (Tr. 77, 91, 161, 168), and comparison and interpretation of exhibits which speak for themselves (Tr. 90, 120, 161, 168).

**(3) Curtailment of cross examination of the witness Russell A. Peterson—the taxpayer—to show bias, prejudice, interest and inconsistent position.**

During cross examination Peterson volunteered that the government had not attempted to collect the alleged deficiency. (Tr. 148). The defendant's trial counsel sought

to inquire as to whether the government had pressed any claim against Peterson so as to show bias or interest of Peterson as a witness. The government's objection to this line of inquiry was sustained (Tr. 148-150). The government agent, Tucker, admitted that the record showed that no additional assessments were made against Peterson (Tr. 42). Defendant's trial counsel asserted that the purpose of his inquiry was to inquire of "any interest . . . anything else he [Peterson] may have obtained from the prosecution . . ." (Tr. 148). Nevertheless the government's objection was sustained. (Tr. 149-150).

Defendant's exploration of settlement of an accounting suit between him and Peterson was curtailed on objection of the prosecution. (Tr. 142-146). Evidence of this settlement objected to by the government when testimony was being taken, was then the subject of comment on failure to produce in closing argument. (Tr. 211).

#### 4. Improper argument of prosecuting attorney.

Apart from questions of evidence, the defendant moved to dismiss or alternatively for a mistrial because of statements made by the United States Attorney in his concluding argument. (Tr. 223-224). The basis of the asserted error is comment upon evidence which could be produced only by testimony of defendant or his attorneys, and upon the failure to produce evidence in regard to the settlement between Peterson and defendant. When defendant attempted to cross examine Peterson about the settlement,



the government's objections to the line of inquiry were sustained. On this appeal the defendant does not urge error in denial of his motion to dismiss based upon the prosecutor's argument, but does assert error in the failure to declare a mistrial. The portion of the argument which defendant asserts entitled him to a mistrial is found at Tr. 211, 214:

"Now, there is always a great deal of stress laid upon the fact that Mr. Peterson disclaimed that he had made assertions for these particular funds against Mr. Leathers and that stuff. Where is the settlement, if the settlement is so important that the defendant entered into with Mr. Peterson? What other items were asserted, and so forth? What are the circumstances that went into any such settlement? (Tr. 211).

\* \* \*

"Now, Ladies and Gentlemen of the Jury, where would you find a wilfull intent on the part of Mr. Peterson? The inference without any evidence to support it, no work sheet other than this 17, being exhibit 17, being in evidence, the inference is that Mr. Leathers, although there is no evidence whatsoever to support it, again, I say is that he had some other work sheet. Where is such a work sheet? Where is whatever it was that Mr. Leathers showed to Mr. Amos at the office of Mr. Vonderheit? If there is another one, where is it . . .? \* \* \* There is no point bringing in Carlson in here with conversation we couldn't record on the witness stand of his conversations with Mr. Peterson. So, talking about matters not introduced here to refute the Government's case where, if there is a different work sheet, if Mr. Peterson altered his work sheet and handed it to Mr. Leathers, where is it?" (Tr. 214).

## SPECIFICATION OF ERRORS

### Failure to Prove Violation of 26 U.S.C. §145(b).

1. The trial court erred in denying defendant's motion for a directed verdict of acquittal on Count 1 of the indictment. (Tr. 190-197).

### Admission and Use of Peterson's Sea Foods' Books and Records.

2. The trial court erred in admitting Exhibit 17 into evidence, the substance of which exhibit is a purported summary of Peterson's Sea Foods' books, showing a statement of gross receipts and a particularization of expenses of Peterson's Sea Foods over defendant's objections that: (Tr. 77).

“Mr. Darling: The first objection we would have would be that there has been no proper foundation laid, that this is not the best evidence, this is a carbon copy, and no foundation has been laid or explanation showing why the best evidence is not introduced.”

3. The trial court erred in permitting the following series of questions of the witness Barrow interpreting Exhibit 17 over defendant's objections (Tr. 90-92).

“Q. May I inquire, Mr. Barrow, can you tell us whether or not, [110] however, the sum \$236,555.64 corresponds to the total receipts as you computed them from the books and records?”

“Mr. Darling: No, just a minute. Your Honor, we would like at this time again to preserve our objection

to any testimony from this Exhibit 17. It is on the grounds that it is not the best evidence and that there has been no showing that it is relevant in any way in this case as having ever come into the hands of the accused in this case. And any such testimony, without such a foundation, in our opinion is irrelevant and prejudicial and should not be admitted until such time as they do lay a proper foundation. So, both for the lack of proper foundation and the fact that it is not the best evidence, we object, and also because it is irrelevant and immaterial.”

\* \* \*

“The Court: I think technically, Mr. Luckey, we might avoid the objection if you will just ask him to read what the exhibit shows.

“Mr. Luckey: Thank you.

“Q. What does the exhibit show, Mr. Barrow, with reference to total receipts, Exhibit No. 17?

“A. The total of the receipts, merchandise, sales, gross, is \$277,555.64 with an allowable deduction, as I said before, of commissions paid from the face of the invoice of \$4,364.64. The results would be the net sales.”

4. The trial court erred in permitting the following series of questions of the witness Cosper interpreting Exhibits 14, 17 and 16 over defendant’s objections (Tr. 160-162):

“Q. Did you reconcile or did you compare those with the returns? A. I did.

“Mr. Darling: If the Court please——[188]

“The Court: Yes.

“Mr. Darling: —I wish at this time to interpose an objection to any testimony by this witness with reference to findings that he made by any comparison of Exhibit 3 with these records, on the ground that there has been no foundation laid to show that these were the records, were the authentic records as kept by Mr. Barrow. Mr. Barrow said that he had not examined them, that they appeared to be the records but he did not examine them and could not testify as to their authenticity. For all the record shows, they could have been in other hands and altered pages put in or something of that type. We further object on the ground that the Exhibit 17 is the exhibit that we have objected to all the way along as not being the best evidence, no testimony that was ever shown to the defendant in this case or that the defendant had ever had any access to the records. In fact, there is positive testimony by the Government that there was never any access by Mr. Leathers or he did not have any—did not at any time consult any of the books himself. And to that extent we make our objection to any testimony, to any findings that he made from these comparisons of the various records.

“The Court: Objection overruled.

\* \* \*

“Q. What did you find with reference to that comparison?”

“A. Well, the sales on the return was understated forty-one thousand dollars under the total sales shown in the ledger and shown on Exhibit 17.”

5. The trial court erred in overruling defendant’s objection to the following series of questions relating to Russell A. Peterson’s personal expenditures asked of the witness Barrow, Tr. 119-120):

“Q. Exhibit 17 would show you?

“A. That’s all right. Either one or both.”

(Whereupon the Crier hands a document to the witness.)

\* \* \*

“Mr. Darling: We would object on the ground it is incompetent, irrelevant and immaterial.

“Mr. Luckey: I think, your Honor, that the next question will be if these expenditures were made from the business receipts for the year in question.

“The Court: I see. You may inquire.

“Mr. Darling: We would like at this time, since the [142] defendant—the witness has Government’s Exhibit 17—we would like at this time to again renew our objection as previously made to the use of Government’s Exhibit 17.

“The Court: Objection overruled.

“Mr. Darling: Exception, please.

“The Witness: Now, this is it—taken from the control ledger, and it is Mr. Peterson’s account, which was 500. Mr. Peterson personally spent \$22,007.85.”

### **Curtailed Cross Examination of Russell A. Peterson**

6. The trial court erred in sustaining the government’s objection to defendant’s cross examination of Russell A. Peterson as to whether the government had ever indicated that he would not be liable for his taxes. The question and objection are at page 148 of the transcript:

“Q. Have they ever indicated to you that you would not be liable for the taxes?



“A. They—

“Mr. Luckey: If the Court please, I have to object to that as being irrelevant.

“The Court: Objection is sustained.

“Mr. Darling: Might I make a record, the reason for the inquiry?

“The Court: You may.

“Mr. Darling: The basis of that inquiry, it is our understanding that we are at all times entitled to inquire of any witness concerning any interest, any promise of [174] immunity, anything else that he may have obtained from the presentation in a case like this.

“The Court: He said the Government has said nothing to him about it.

“Mr. Darling: Well, I was merely addressing a further question on that same line.

“Mr. Luckey: If he wants to ask him if he has been promised any immunity or anything, that would be fine.

“The Court: It is entirely different from whether or not the Government is pressing any claim against him. I will abide with my ruling.”

7. The trial court erred in sustaining the Government's objection to defendant's cross examination of Russell A. Peterson as to whether the Government had ever made a demand upon him for his taxes. The question and objection are at page 150 of the transcript:

“Q. Well, now since that time has the Government ever made any demand upon you for the payment?

“Mr. Luckey: If the Court please—

“Mr. Darling: — — of the difference between the tax as shown on the 1946 return and the tax that they claim should have been paid based on what they and you considered to be your true income for the year 1946?”

“Mr. Luckey: If the Court please, I have to renew the same objection that I have been making to the same type of inquiry as to whether or not the Government has made demands upon the witness for the difference in the tax on the same [176] basis that it has been urged and sustained before.

“The Court: It will be sustained.”

8. The trial court erred in sustaining government’s objection to cross examination of Russell A. Peterson to show his prior inconsistent position. The question and objection are found at pages 145-147 of the transcript:

“Q. Just a minute. Don’t tell us what somebody else said. Isn’t it also true, Mr. Peterson, that in the course of that settlement and as a part of the settlement you did not make any demand and did not require Mr. Leathers to make good any sum to the Federal Government?”

“A. You would have to contact my attorney.

“Mr. Luckey: If your Honor please—[171].

“The Court: Just a moment. What is it?”

Mr. Luckey: Mr. Darling asked him to state whether or not he could require any sum to be paid to the Federal Government. I suggest that it would be impossible for Mr. Peterson to require it.

“Mr. Darling: Well, if the Court please, if I may make that clear, the reason for that statement is that when I asked him whether or not in the course of his

settlement he made any demand against Mr. Leathers that Mr. Leathers had obtained some sixteen thousand dollars from him in property he said, 'No, that was to be paid by Mr. Leathers to the Government.'

"The Court: Yes.

"Mr. Darling: Then I feel on the basis of that I have the further right to inquire, well, then, as a part of the settlement did he require Mr. Leathers to make good that sum.

"The Court: Well, you are going on the assumption that he had some duty to make such a request and that he didn't do it and that, therefore, what he now claims is adverse to his position.

"Mr. Darling: I am going on the assumption and, of course, we will make our argument on that basis, that if the situation was as he is now claiming that Mr. Leathers owed him sixteen thousand dollars by reason of his ten thousand dollar [172] check and this ten thousand dollar note that he gave.

"The Court: I don't understand the Government is so contending.

"Mr. Darling: Well, that is the whole theory of this case, as we see it.

"The Court: Well, I will sustain the objection."

### **Improper Argument of Prosecuting Attorney**

9. The trial court erred in denying defendant's motion for a mis-trial (Tr. 223-224) based upon the improper closing argument of the United States Attorney in commenting on defendant's failure to produce evidence provable only by defendant's testimony or the testimony of defendant's attorney (Tr. 211, 214).

## ARGUMENT

### SUMMARY

The defendant contends that there is absolutely no testimony to show that he had any knowledge of the gross receipts of Peterson's Sea Foods.

The defendant claims error in two particulars related to the curtailment of his cross examination of Peterson, the taxpayer. First, denial of his right to show Peterson's financial interest in cooperating with the prosecution. Second, denial of his right to show Peterson's prior inconsistent position in civil litigation between Peterson and defendant. In that litigation Peterson was given an accounting from defendant and did not claim the moneys which he now testifies were paid defendant on account of taxes.

While the use of Peterson's Sea Foods' books were necessary to satisfy the prerequisite of proving a tax due, they should not have been admitted for any other purpose until connected with the defendant. The repetitious interpretation of these books and the summary sheet was also error in view of the failure to connect them to the defendant.

During closing argument the United States Attorney eight or nine times asked where records were which could only have been in the possession of defendant or his counsel and could only have been introduced by testimony of defendant or his counsel. This argument constituted a com-

ment on defendant's failure to testify and deprived defendant of due process and his privilege against self-incrimination.

## I.

### DEFENDANT'S MOTION FOR A DIRECTED VERDICT OF ACQUITTAL ON COUNT ONE SHOULD HAVE BEEN GRANTED.

A. There is no evidence that defendant wilfully evaded Peterson's taxes. (This brief, *supra*, pp. 4-7, Tr. 78, 118, 132, 137, 157-159).

B. When there is no evidence of intent to wilfully evade a tax, there can be no conviction.

*Bloch v. United States*, (9 Cir., 1955), 221 F.2d 786.

*United States v. Lindstrom*, (3 Cir., 1955), 222 F.2d 761.

*Jones v. United States*, (5 Cir., 1947), 164 F.2d 398.

The record relative to the charge as discussed, *supra*, 4-7, taken as most favorable to the prosecution shows:

1. That Peterson owed more taxes than he paid.

2. That Peterson's Sea Foods' books prove that Peterson underpaid his tax.

3. That defendant signed both his and Peterson's name to the tax return.



The record affirmatively shows that none of the witnesses had any knowledge of defendant ever having access to the books and records which the government relied upon to show Peterson's underpayment. (Supra, pp. 00). There is nothing in the record to show that defendant had any knowledge that he was under-reporting Peterson's income. The suggestion that defendant may have had evil motives relative to Peterson's property are totally irrelevant.

The law is clear that no conviction may be had under former 26 U.S.C. §145(b) without proof of actual intent to cheat the government. This court thoroughly analyzed the problem in *Bloch v. United States*, 221 F.2d 786, and affirmed its conclusion in opinion denying a petition for rehearing at 223 F.2d 997. The holding of the court was that to sustain a conviction a state of mind to cheat the government must be proven, at 221 F.2d 789:

“In this Section 145(b) tax evasion case there is only one state of mind that will supply the intent necessary to sustain a conviction, and that is the intent to defeat or evade the payment of the tax due. Nor would filing a false return with any bad purpose supply the necessary intent. *The bad purpose must be to evade or defeat the payment of the income tax that is due.* Nor would filing a false return without a justifiable excuse or without ground for believing it to be lawful or with a careless disregard for whether or not one has the right so to do constitute in themselves the intent which is required under the section. (Emphasis Supplied).

“The practice of attempting to convict a defendant not of the crime of which he is charged, but rather of being an all around, no good dissolute person, is foreign to our system and is disapproved by this Court.”

This rule, that an intent to cheat the government must be proven, is affirmed by other Circuits. Proof that a family partner understates income, is not proof of wilful evasion. *United States v. Lindstrom*, (3 Cir., 1955), 222 F.2d 761. Intent is never presumed. Even the failure to return income and pay a tax is not sufficient to establish intent. *Jones v. United States*, (5 Cir., 1947), 164 F.2d 398.

Here we do not even have testimony to show knowledge of under-reporting. We have no evidence of intent to evade taxes. It therefore follows that defendant's motion (Tr. 190-197) for a directed verdict on Count 1, charging violation of 26 U.S.C. §145(b) (Internal Revenue Code of 1939), should have been allowed.

## II.

### PETERSON'S BOOKS WERE IMPROPERLY ADMITTED AND USED.

- A. There is no testimony to connect defendant with the books and records of Peterson's Sea Foods (Tr. 78, 95, 118, 132, 137).
- B. The books and records are not evidence against defendant (Tr. 78, 91 *supra* pp. . . .).

Defendant recognizes that the government must attempt to prove that taxes were underpaid, and that the taxpayer's books may be used for this purpose. However, the taxpayer's books (Exs. 14, 15, 16) and the taxpayer's bookkeeper's summary (Ex. 17) were repeatedly and continually the subject of direct examination seeking interpretations and analysis over defendant's vigorous objection (Tr. 77, 79, 80, 90-92, 120, 161, 168-169). These exhibits were never connected to defendant. (Supra, pp. 4-7).

The Court recognized that until such connection, the taxpayer's books were not binding on defendant. (Tr. 78). Indeed the original admission of the bookkeeper's summary was solely to show his analysis of the books. (Tr. 91).

The defendant submits that the continual use of the taxpayer's books created an environment in which they were associated with and bound the defendant. In view of the total failure of proof that defendant had access to the exhibits, despite earlier assurances by the government (Tr. 78), use of the books for any purpose other than showing a tax deficiency constituted error.

## III.

DEFENDANT'S IMPEACHING CROSS EXAMINATION OF RUSSELL A. PETERSON TO SHOW BIAS, PREJUDICE, INTEREST AND INCONSISTENCY WAS ERRONEOUSLY CURTAILED.

- A. Peterson had an interest in avoiding or reducing his potential tax liability.
- B. The evidence shows that Peterson may have had a hope of reducing his tax liability by testifying against defendant (Tr. 148).
- C. The evidence shows civil litigation between Peterson and defendant (Tr. 144).
- D. Defendant had a right to place Peterson in his proper setting, to show claims he may have had against defendant, to show bias, and to show beliefs or hopes Peterson may have had for favorable treatment by the government.

*Alford v. United States*, (1931) 282 U.S. 687, 51 S. Ct. 218, 75 L.Ed. 624.

*United States v. Cohen*, (3 Cir., 1947), 163 F.2d 667.

*McFarland v. United States* (D.C., C.A., 1949), 174 F.2d 538.

*United States v. Beckman*, (2 Cir., 1946), 155 F.2d 580.

*Meeks v. United States* (9 Cir., 1947), 163 F.2d 598.

*Gordon v. United States*, (1953) 344 U.S. 414, 73 S. Ct. 369, 97 L.Ed. 447.

*Villaroman v. United States* (D.C., C.A., 1950), 184 F.2d 261, 21 A.L.R. 2d 1074.

Defendant is charged with attempting to evade Peterson's income taxes for 1946 to the amount of \$24,967.16. (Tr. 4). This figure is reached by subtracting the amount paid, \$4,010.25, from the total allegedly due \$28,977.41 (Tr. 4).

Peterson claimed he gave \$16,000 to defendant to pay his tax (Tr. 147). Peterson also claimed to have no knowledge of the return itself, but asserted that defendant had prepared it. (Tr. 157). Peterson admitted that the government had made no demand on him for any tax deficiency (Tr. 148). At that point defendant's counsel cross questioned Peterson (Tr. 148):

“Q. Have they [the Government] ever indicated to you that you would not be liable for the taxes?”

The government's objection based on relevancy was allowed. (Tr. 148).

The evidence shows litigation between Peterson and defendant, and Peterson's belief that to get satisfaction he “had to sue him (defendant).” (Tr. 144). In the course of settlement of that accounting suit, Peterson made no de-



mand for the \$16,000 he testified he gave defendant. (Tr. 145). This testimony was inconsistent with his testimony during trial of payment to defendant of \$16,000 for taxes. It is inconsistent because it showed that at a prior time, when if Peterson had paid the monies to defendant on account of taxes he could have demanded an accounting, he entertained no belief that he was due an accounting for the \$16,000. It shows that Peterson at the time of the accounting did not contend that he paid \$16,000 to defendant in the belief that defendant had paid \$16,000 on account of Peterson's taxes. The government, despite prevailing in its objection to exploration of the civil settlement and litigation, commented in closing argument on the fact that the defendant had not produced it and asked the terms of the settlement. (Tr. 211).

The evidence shows an active animus on Peterson's part, and an interest in escaping both criminal and civil liabilities.

Under such circumstances defendant has a right to place Peterson—the taxpayer and the chief prosecution witness—in his proper setting—to show inconsistencies—to show any interest or prejudice—to show any expectancies he may have had in return for his testimony.

Hence, in *United States v. Cohen*, (3 Cir., 1947), 163 F.2d 667, an OPA prosecution involving alleged over ceiling sale of an automobile, reversible error was found in the refusal of the court to permit cross examination of the

chief prosecuting witness as to a \$1,300 civil demand against defendant. The Court cited *Alford v. United States*, (1931), 282 U.S. 687 at 692, 51 S. Ct. 218, 75 L.Ed. 624 for the principal that:

“Prejudice ensues from a denial of the opportunity to place the witness in his proper setting and put the weight of his testimony and credibility to a test, without which the jury cannot fully appraise them.”

The *Alford* Case, while recognizing the power of the trial court, establishes broad standards of permissible exploratory cross examination to show bias, prejudice, or fear on the part of the witness.

It is true that the trial court permitted inquiry as to whether immunity from criminal liability had been promised Peterson. However, promises of criminal immunity are rare. That was recognized in *Farkas v. United States*, (6 Cir. 1924) 2 F.2d 644, an extortion case in which error was found in the refusal to permit impeaching cross examination of accomplices who had plead guilty and were awaiting sentence. At 2 F.2d 674:

“Concededly promises of immunity are admissible; they are, however, rarely made . . . the relevant evidence is not alone the acts or attitude of the district attorney but anything else that would throw light upon the prosecuting witnesses’ state of mind. It is therefore entirely proper . . . to show a belief or even a hope . . . that he will secure immunity or a lighter sentence, or any other favorable treatment in return for his testimony, and that, too, even if it be fully conceded that

he had not the slightest basis from any act or word of the district attorney for such a belief or hope.”

It is therefore not the enforceability of the hope for favor—but the existence of the hope which is an appropriate subject of cross examination. Similarly, it is error to exclude a showing of a basis of fear or of sanctions on the part of prosecution witnesses. In *United States v. Beekman*, (2 Cir., 1946), 155 F.2d 580, an OPA case, the Court pointed out that witnesses subject to government supervision “might be facile witnesses against other alleged offenders.” Error was found in the refusal to permit the defense to show this basis of fear—the opposite face of which is a hope for reward or pardon.

The rule permitting inquiry into the state of mind of a witness—his hopes and fears—is most frequently applied when the fate of a witness is in the hands of another person, usually a court. *Gordon v. United States*, (1953), 344 U.S. 414, 73 S. Ct. 369, 97 L.Ed. 447, *Meeks v. United States*, (9 Cir., 1947) 163 F.2d 598. Here the fate of Peterson was in the hands of the Internal Revenue Service. The Service could demand almost \$25,000 from Peterson—or they could forget about it and administratively forgive him.

When the basis of a witness’ prejudice may be personal animosity, there are no limits to the exploration of the source of that prejudice. Hence, in *McFarland v. United States*, (D.C., C.A., 1949), 174 F.2d 538, a perjury charge,

the appellate court found reversible error in denying defendant the right to show that the prosecuting witness engaged in extra-marital intercourse with the defendant. Broad inquiry into possible prejudice is always permitted because bias is always a relevant subject of cross examination. *Villaroman v. United States*, (D.C.C.A., 1950), 184 F.2d 261, 21 A.L.R. 2d 1074.

The relevance of the inconsistent position of Peterson, in failing to claim in the accounting between himself and the defendant the \$16,000 which he now testifies was his money paid on account of taxes, requires no discussion. Inconsistent positions are always relevant for impeachment purpose.

To summarize:

1. Defendant was denied the right to show by cross examination Peterson's bias prejudice and interest because of:

- (a) Hoped for immunity from tax liability.
- (b) Hope for immunity from penalties.
- (c) Fear of liability or penalties.

2. Defendant was denied the right to show by cross examination Peterson's inconsistent position regarding the \$16,000.

These unreasonable restraints on defendant's right of cross examination deprived him of a fair trial, and if de-

fendant's first assignment of error is denied, entitled him to a new trial.

#### IV.

### THE UNITED STATES ATTORNEY'S ARGUMENT DEPRIVED DEFENDANT OF RIGHTS GUARANTEED BY THE FIFTH AMENDMENT TO THE CONSTITUTION.

- A. The settlement between Peterson and Leathers, the circumstances of the settlement, the items asserted, the work sheet defendant and his attorney showed government agent, Amos, and any other work sheet used by defendant were provable only by testimony of defendant or his attorney (Tr. 146-147, 168, 159, 165, 168).
- B. The United States Attorney, in his closing argument, repeatedly referred to and commented upon the defendant's not producing these documents (Tr. 211, 214).
- C. A defendant is deprived of due process and his privilege against self incrimination is vitiated if a prosecuting attorney refers to failure to produce evidence provable only by his testimony or the testimony of his attorney.

*Linden v. United States* (3 Cir., 1924) 296 Fed. 104.

*Barnes v. United States* (8 Cir., 1925) 8 F.2d 832.



*State v. Swan* (1946), 25 Wash. 2d 319, 171 P. 2d 222.

*Yates v. United States* (9 Cir., 1955) 227 F.2d 851.

Examination of each of the items whose location is referred to and which defendant's failure to produce were repetitiously charged in closing argument (*Supra*, p. 9) demonstrates that they were provable only by testimony of defendant or his attorney.

**(a) Settlement between Peterson and Leathers.**

Mr. Luckey: \* \* \* (Tr. 211).

"Where is the settlement . . .

"What other items were asserted?

"What are the circumstances . . ."

The settlement by its nature would be within the knowledge of four people; Peterson, Leathers, and their attorneys. Peterson's attorney could not be called. When defendant sought to inquire of Peterson about the details of the settlement, the government's objection to exploration of the subject was sustained (Tr. 146-147). Therefore, by elimination, only defendant or his attorney could testify about the settlement, the items asserted in it, and the circumstances surrounding it.

**(b) The Work Sheet defendant and his attorneys exhibited to the government agents and any other work sheet defendant may have used.**

Mr. Luckey: \* \* \* (Tr. 214).

“Where is such a work sheet?”

“Where is whatever it was that Mr. Leathers showed to Mr. Amos at the office of Mr. Vonderheit? . . .

“Where is it?”

“Where, if there is a different work sheet, if Mr. Peterson altered his work sheet and handed it to Mr. Leathers, where is it?”

Defendant and his attorney showed a work sheet to Mr. Cospers (Tr. 159), in the office of defendant’s attorneys (Tr. 165). At that time, Mr. Amos also discussed the preparation of Peterson’s tax with defendant and briefly saw defendant’s work sheets (Tr. 168). The testimony of Cospers and Amos shows that the work sheets had to be in the possession of defendant, or his attorneys. Only defendant could testify as to work sheets given him by the taxpayer.

\* \* \*

In closing argument, the prosecution asked interrogatories relative to the foregoing, prefaced by “where” or “what” many times (Tr. 211, 214). The law is clear that argumentative challenges to a defendant to produce evidence solely within his knowledge or argumentative reference to his failure to produce such evidence which would require his testimony is reversible error.

A closely analogous situation is found in *Linden v. United States*, (3 Cir., 1924), 296 Fed. 104, an appeal from a

conviction of violating the prohibition laws. The judge, in commenting upon the evidence pointed out that the testimony as to one count was uncontradicted. While the right of the trial judge to comment was recognized, the appellate court pointed out that the only persons present at the occasion testified to were the witnesses and the defendants. Since the only persons who could contradict the witnesses by testimony were the defendants, the comment was held to be a comment on failure to testify and the conviction was reversed.

In this case the only person other than Peterson who could testify as to the settlement was the defendant. The only persons shown to have possession of the work sheet and to be present when the work sheet was exhibited by the defendant to Amos and Cospers were the defendant or his attorneys. The only person who could testify that Exhibit 17 was not shown to defendant, was defendant. No witness testified that defendant had access to Exhibit 17.

The direct question of argument of the prosecuting attorney arose in *Barnes v. United States*, (8 Cir., 1925) 8 F.2d 832, a narcotics conviction. The alleged sale took place when only the defendant and the witness were present. The argument of the prosecuting attorney that the testimony of the witness was uncontradicted was held to require reversal despite the appellate court's belief that guilt was clear. In the case now on appeal only the defendant could testify as to the challenges made by the

prosecuting attorney relative to the settlement and the work sheets.

In *State v. Swan*, (1946) 25 Wash. 2d 319, 171 P. 2d 222, a manslaughter conviction appeal, the prosecutor had argued the failure of the defendant to call his wife. The comments on refusal to waive the husband-wife privilege were held to require reversal. The principal would encompass the defendant's attorney, the only other person shown to have knowledge of the settlement or work sheets shown Amos.

In this case we have two types of argument of the prosecuting attorney relative to the defendant's failure to produce evidence provable only by his testimony:

1. Relating to the settlement between Peterson and defendant: Peterson was on the stand as the government's witness. The government successfully objected to exploration of the settlement by examination of Peterson. Hence the only witness left to testify about the settlement was defendant.

2. Relating to the work sheet defendant showed Amos: The work sheet was in the possession of defendant. Only he, or perhaps his attorney, could have produced it. Only defendant, his counsel, and the witnesses were present. Only defendant or his counsel could testify on the subject.

As this court held in *Yates v. United States*, (9 Cir., 1955) 227 F.2d 851, at 853:

“In our system, there is an impregnable bastion erected to protect a defendant not only against self incrimination, but even against a compulsion to testify. As long as a defendant remains within the barbican of his guarantee, protection is absolute. The prosecutor cannot comment on this silence.”

Mr. Leathers remained within the barbican of the guarantee. The prosecutor commented on failure of the defendant to produce evidence equally in defendant's possession and possession of the government's chief witness, whose testimony on the point was halted by the prosecution's objection. Hence, after the successful objection only the defendant could have testified. The prosecutor commented on defendant's failure to produce evidence shown to be capable of production only by the defendant's testifying. This conduct demands reversal.



## CONCLUSION

The failure to present evidence to support a conviction requires reversal and granting defendant's motion for a directed verdict. If this assignment of error is not allowed, improper admission and use of evidence, improper restraints on defendant's right to cross examine witnesses, and improper argument of the United States Attorney require reversal of the verdict and judgment below.

Respectfully submitted,

RAYMOND M. KELL  
CLIFFORD B. ALTERMAN  
*Attorneys for Appellant*

Portland, Oregon  
June, 1957

No. 15429

---

---

**United States  
Court of Appeals**  
for the Ninth Circuit

---

H. P. WILLMAN, Doing Business as Poppers  
Supply Co.,

Appellant,

vs.

HAROLD M. ALVER, OSCAR J. ALVER, RAY-  
MOND N. ALVER, LUCILE M. ALVER,  
JEANNETTE B. ALVER and MILDRED M.  
ALVER, a Co-partnership Doing Business as  
Premier Popcorn Company,

Appellees.

---

**Transcript of Record**

---

Appeal from the United States District Court for the  
District of Oregon



No. 15429

---

---

United States  
Court of Appeals  
for the Ninth Circuit

---

H. P. WILLMAN, Doing Business as Poppers  
Supply Co.,

Appellant,

vs.

HAROLD M. ALVER, OSCAR J. ALVER, RAY-  
MOND N. ALVER, LUCILE M. ALVER,  
JEANNETTE B. ALVER and MILDRED M.  
ALVER, a Co-partnership Doing Business as  
Premier Popcorn Company,

Appellees.

---

Transcript of Record

---

Appeal from the United States District Court for the  
District of Oregon





## INDEX

---

[Clerk's Note: When deemed likely to be of an important nature, errors or doubtful matters appearing in the original certified record are printed literally in italic; and, likewise, cancelled matter appearing in the original certified record is printed and cancelled herein accordingly. When possible, an omission from the text is indicated by printing in italic the two words between which the omission seems to occur.]

	PAGE
Answer .....	5
Attorneys, Names and Addresses of .....	1
Certificate of Clerk .....	96
Complaint .....	3
Defendant's Requested Instructions .....	25
Judgment .....	29
Notice of Appeal .....	31
Order Re Transmittal of Exhibits .....	33
Plaintiffs' Requested Instructions .....	19
Pretrial Order .....	8
Statement of Points Upon Which Appellant Intends to Rely on Appeal .....	99
Stipulation Re Exhibits Attached to Pretrial Order .....	19
Transcript of Proceedings .....	34

## Witnesses :

Alver, Harold M.

—direct .....	35, 83
—cross .....	54, 84
—redirect .....	58, 85

Bennett, Noel

—direct .....	76
—cross .....	78, 81

Willman, Herman P.

—direct .....	61, 65
—cross .....	71
—redirect .....	72
—recross .....	74

Undertaking on Appeal Supersedeas .....	32
---	----

In the United States District Court  
for the District of Oregon

Civil No. 8500

HAROLD M. ALVER, OSCAR J. ALVER, RAY-  
MOND N. ALVER, LUCILE M. ALVER,  
JEANNETTE B. ALVER and MILDRED M.  
ALVER, a Co-partnership Doing Business as  
PREMIER POPCORN COMPANY,

Plaintiffs,

vs.

H. P. WILLMAN, Doing Business as POPPERS  
SUPPLY CO.,

Defendant.

### COMPLAINT

Plaintiffs, for cause of action against the De-  
fendant, complain and allege:

#### I.

That at all times mentioned herein, the Defend-  
ant was, and now is, a resident, inhabitant and  
domiciliary of the State of Oregon, and was, among  
other things, engaged in business as a popcorn job-  
ber under the name and style of Poppers Supply  
Co., and maintained on file in the records of the  
County Clerk of Multnomah County, Oregon, an  
assumed business name certificate as required by  
law.

#### II.

That at all times mentioned herein the Plaintiffs  
were and now are co-partners engaged under the

ORIGINAL ARTICLES

1. The Effect of the Diet on the Blood Sugar in the Normal Individual  
2. The Effect of the Diet on the Blood Sugar in the Diabetic Individual  
3. The Effect of the Diet on the Blood Sugar in the Obese Individual  
4. The Effect of the Diet on the Blood Sugar in the Hypertensive Individual  
5. The Effect of the Diet on the Blood Sugar in the Aged Individual

6. The Effect of the Diet on the Blood Sugar in the Pregnant Individual  
7. The Effect of the Diet on the Blood Sugar in the Postoperative Individual  
8. The Effect of the Diet on the Blood Sugar in the Post-traumatic Individual  
9. The Effect of the Diet on the Blood Sugar in the Post-infectious Individual  
10. The Effect of the Diet on the Blood Sugar in the Post-surgical Individual

In the United States District Court  
for the District of Oregon

Civil No. 8500

HAROLD M. ALVER, OSCAR J. ALVER, RAY-  
MOND N. ALVER, LUCILE M. ALVER,  
JEANNETTE B. ALVER and MILDRED M.  
ALVER, a Co-partnership Doing Business as  
PREMIER POPCORN COMPANY,

Plaintiffs,

vs.

H. P. WILLMAN, Doing Business as POPPERS  
SUPPLY CO.,

Defendant.

### COMPLAINT

Plaintiffs, for cause of action against the De-  
fendant, complain and allege:

#### I.

That at all times mentioned herein, the Defend-  
ant was, and now is, a resident, inhabitant and  
domiciliary of the State of Oregon, and was, among  
other things, engaged in business as a popcorn job-  
ber under the name and style of Poppers Supply  
Co., and maintained on file in the records of the  
County Clerk of Multnomah County, Oregon, an  
assumed business name certificate as required by  
law.

#### II.

That at all times mentioned herein the Plaintiffs  
were and now are co-partners engaged under the



assumed name and style of Premier Popcorn Company in the State of Illinois in the business of processing and selling popcorn to wholesalers and others. That the Plaintiffs are and were at all times mentioned herein residents, inhabitants and domiciliaries of the State of Illinois.

### III.

This is a civil action between citizens of different states, where the matter in controversy exceeds \$3,000.00 exclusive of interest and costs. [1\*]

### IV.

That on or about May 11, 1953, the Defendant, in writing, contracted to buy from Plaintiffs, and Plaintiffs, in said writing, contracted to sell to Defendant, for future delivery, 7,200 one hundred pound bags of S. A. Yellow Hybrid Variety "Golden Rocket" Popcorn, warranted to pop 30 to 1 on the official volume tester, for the sum of \$9.00 per hundred pounds, including bags, f.o.b. Watseka, Illinois.

### V.

That the parties hereto mutually agreed, in writing, to the cancellation of so much of said contract as called for the purchase and sale of 3,600 one hundred pound bags of said corn.

### VI.

That the Plaintiffs duly performed, and were, at all times mentioned herein, ready, willing and able

---

\*Page numbering appearing at foot of page of original Certified Transcript of Record.

to duly perform, all of the conditions and promises on their part of said contract to be performed.

VII.

That the Defendant, prior to April 14, 1954, and subsequent to May 11, 1953, breached, repudiated and renounced the aforementioned contract to purchase 3,600 one hundred pound bags of popcorn, and as a direct result and consequence of said breach, Plaintiffs suffered damage in the sum of \$11,700.00.

Wherefore, Plaintiffs demand judgment against Defendant for the sum of \$11,700.00, and for their costs and disbursements incurred herein.

/s/ WM. E. TASSOCK,  
Of Attorneys for Plaintiffs.

[Endorsed]: Filed March 2, 1956.

---

[Title of District Court and Cause.]

ANSWER

First Defense

The complaint fails to state a claim against the defendant upon which relief can be granted.

Second Defense

The plaintiffs are not the real parties in interest and not the proper parties plaintiff.

### Third Defense

The defendant admits the allegations contained in Paragraph I of the Complaint; alleges that he is without knowledge or sufficient information to form a belief as to the truth of the allegations contained in Paragraph II of the Complaint; and denies each and every other allegation contained in the Complaint except so much thereof as is set forth in the defendant's affirmative defense.

### Fourth Defense

Plaintiffs' Complaint is not based on any of the remedies to which they are limited by the contract allegedly breached.

### Fifth and Affirmative Defense

#### I.

That on or about May 11, 1953, the defendant, in writing, contracted to buy and the plaintiffs contracted to sell 7,200 100 lb. bags of S. A. Yellow Hybrid variety "Golden Rocket" popcorn, for the sum of \$9.00 per hundred pounds, including bags, f.o.b. Watseka, Illinois. [2]

#### II.

That the parties hereto mutually agreed to reduce the quantity of popcorn ordered from 7,200 100-lb. bags to 3,600 100-lb. bags.

#### III.

That the parties hereto further mutually agreed to reduce the price per 100 lbs., including bags, from \$9.00, as aforesaid, to \$8.00.

IV.

That on or about January 5, 1954, the defendant ordered from the plaintiffs and gave shipping instructions for 1,200 100-lb. bags of the aforesaid popcorn at the mutually agreed price of \$8.00, but the plaintiffs failed and refused to ship any popcorn in response to the said order; and the defendant again, on or about February 2, 1954, ordered, and gave shipping instructions, in writing, to the plaintiffs for 3,600 100-lb. bags of the said popcorn at the mutually agreed price of \$8.00, but the plaintiffs failed and refused to ship any of the said popcorn and ignored the orders and shipping instructions of the defendant.

V.

That the defendant duly performed all the conditions of the contract on his part to be performed.

Wherefore, defendant demands that the Complaint be dismissed and that defendant recover his costs and disbursements incurred herein.

/s/ J. P. STIRLING,

/s/ JOHN F. REYNOLDS,

Attorneys for Defendant.

Defendant demands trial by jury under Rule 38 (b).

/s/ J. P. STIRLING,

Of Attorneys for Defendant.

Duly verified.

[Endorsed]: Filed March 22, 1956.

[Title of District Court and Cause.]

## PRE-TRIAL ORDER

### Nature of the Case

This is an action commenced by the plaintiff sellers for damages for alleged breach of contract by the defendant purchaser. The defendant denies that he has breached the contract, but contends the contract was revised.

### Agreed Facts

1. That at all times mentioned herein the defendant was and now is a resident, inhabitant and domiciliary of the State of Oregon, and was, among other things, engaged in business as a popcorn jobber under the name and style of Poppers Supply Company, and maintained on file in the records of the County Clerk of Multnomah County, an assumed business name certificate as required by law.

2. That at all times mentioned herein the plaintiffs were and now are co-partners engaged in the State of Illinois in the business of processing and selling popcorn to wholesalers and others under the assumed name and style of Premier Popcorn Company. That the plaintiffs are and were at all times mentioned herein residents, inhabitants and domiciliaries of the State of Illinois.

3. That this is a civil action between citizens of different states where the amount in controversy exceeds \$3,000, exclusive of interests and costs.



4. That on or about May 11, 1953, the defendant, in a writing herein referred to as Exhibit I, contracted to buy 7,200 one hundred-pound bags of S. A. Yellow Hybrid Variety "Golden Rocket" Popcorn for the sum of \$9.00 per hundred pounds, including bags, f.o.b. Watseka, Illinois.

5. That after May 11, 1953, and prior to May 21, 1953, the plaintiffs, [3] acting by and through H. M. Alver, executed said contract, Exhibit I, in Watseka, Illinois, and did thereby agree to sell said popcorn.

6. On May 20, 1953, plaintiffs, by H. M. Alver, composed, executed and deposited in the United States Post Office in Watseka, Illinois, Exhibit II, which letter was received in due course by defendant.

7. That on or about October 12th, and/or 13th, and/or 14th, 1953, the defendant and H. M. Alver conferred in Chicago. That the defendant and H. M. Alver subsequently had a conversation in Portland, Oregon, in November, 1953.

8. On or about October 23, 1953, a long distance telephone conversation was had between H. P. Willman, who was then and there in Portland, Oregon, and H. M. Alver, who was then and there in Watseka, Illinois.

9. That on October 23, 1953, the plaintiffs composed, executed and deposited in the United States Post Office in Watseka, Illinois, Exhibit III, a let-

ter which was received in due course of mail by the defendant.

10. That on December 15, 1953, the defendant composed, executed and deposited in the United States Post Office in Portland, Oregon, Exhibit IV, a letter which was received in due course of mail by the plaintiffs.

11. That on December 16, 1953, the plaintiffs composed and deposited in the United States Post Office in Watseka, Illinois, Exhibit XIII, a letter which was received in due course of mail by the defendant.

12. On December 22, 1953, the plaintiffs composed and executed Exhibit V, a letter with invoice No. 3093 attached, which was mailed at Watseka, Illinois, on January 2, 1953, via air mail, and received by the defendant in Portland, Oregon, on January 4, 1954.

13. That on January 5, 1954, a telephone conversation was had between H. M. Alver, who was then and there in Watseka, Illinois, and H. P. Willman, who was then and there in Portland, Oregon, and on the same day H. M. Alver composed, executed and deposited with the Post Office in Chicago, Illinois, Exhibit VI, a letter, via air mail, which was received in due course of mail by the defendant.

14. On January 11, 1954, the plaintiffs received in the mail at Watseka, Illinois, Exhibit VII, defendant's Purchase Order No. 1856.

15. Prior to January 28, 1954, plaintiffs retained Malcolm H. Clark, an attorney of Portland, Oregon, to represent them. That on January 28, 1954, Malcolm H. Clark composed, executed and deposited in the Post Office in Portland, Oregon, Exhibit VIII, a letter which was in due course of mail received by defendant.

16. That on or about January 28, 1954, defendant, in Portland, Oregon, talked to plaintiffs' office, in Watseka, via telephone.

17. That on January 28, 1954, the plaintiffs composed, executed and deposited in the Post Office in Watseka, Illinois, via air mail, Exhibit IX, a letter, which was received in due course of mail by the defendant.

18. That on February 2, 1954, J. P. Stirling, an attorney at law, pursuant to authority and direction of the defendant, composed, executed and deposited in the Post Office in Portland, Oregon, Exhibit X, a letter which was received in due course of mail by Malcolm H. Clark, and to which was attached a copy of Purchase Order No. 1867, mentioned below.

19. That on or about February 2, 1954, the defendant composed and deposited in the Post Office at Portland, Oregon, Exhibit XI, Purchase Order No. 1867, directed to plaintiffs, which was received by plaintiffs on February 4, 1954.

20. On February 11, 1954, defendant sent a telegram to plaintiffs, which telegram was received by

plaintiffs in due course, and which is Exhibit XII.

21. That on or about February 15, 1954, plaintiffs mailed to defendant their invoice No. 3153, which invoice was received by defendant (Exhibit XIV).

22. That, prior to the contract of May 11, 1953 (Exhibit I), plaintiff and defendant had a previous written contract for the shipment of corn, dated December 31, 1952, which contract is referred to as Exhibit XV.

23. Defendant gave no shipping instructions under this contract at the \$9.00 price, and plaintiffs shipped no corn thereunder at the \$8.00 price.

24. That the writings referred to herein as Exhibits I through and including XIX are attached to a "Stipulation" concerning Exhibits entered into by the parties, and on file herein, by the terms of which it is admitted that said exhibits are genuine and are what they purport to be and that all or any of said Exhibits may be, without objection, introduced into evidence by either party at the time of and during trial, except as therein stated.

### Plaintiffs' Contentions

#### I.

That plaintiff was at all times ready, willing, and able to ship to defendant popcorn of the kind, quality and quantity referred to in Exhibit I, at the price of \$9.00 per hundred pounds, including bags, f.o.b. Watseka, Illinois.

II.

That defendant breached the contract of May 11, 1953, by:

(1) Failing, within a reasonable time after January 4, 1954, to order from plaintiffs, or pay for, any popcorn of the type and kind covered by the contract at the contract price of \$9.00 per cwt. f.o.b. Watseka, Illinois, and/or

(2) By repeatedly asserting, subsequent to receipt of written notice from plaintiffs that the contract price of \$9.00 per cwt. f.o.b. Watseka, Illinois, would not be altered, a right under the contract to purchase said corn at a price of \$8.00 per cwt. f.o.b. Watseka, Illinois, and/or

(3) By renouncing and repudiating the contract of May 11, 1953.

III.

That the market price of popcorn of the type and quality covered by the contract of May 11, 1953, was at the times indicated as follows:

- October, 1953—\$8.00 per cwt., including bags;
- November, 1953—\$8.00 per cwt., including bags;
- December, 1953—\$7.00 per cwt., including bags;
- January, 1954—\$6.50 per cwt., including bags;
- February, 1954—\$6.00 per cwt., including bags;
- March, 1954—\$6.00 per cwt., including bags;
- April, 1954—\$5.50 per cwt., including bags;
- May, 1954—\$5.50 per cwt., including bags;
- June, 1954—\$5.00 per cwt., including bags;
- July, 1954—\$5.00 per cwt., including bags;



August, 1954—\$7.00 per cwt., including bags;  
September, 1954—\$7.00 per cwt., including bags.  
All prices f.o.b. Watseka, Illinois.

## IV.

That by virtue of defendant's breach as aforesaid, plaintiffs are entitled to recover damages computed at:

(1) The difference between the contract price and the market price prevailing for 600 100-lb. bags for each of the months of January, February, March, April, May and June of 1954.

or

(2) The difference between the contract price and the market price for 600 100-lb. bags of popcorn of the kind covered by the contract for each of the months of October, November, December, 1953, and January, February and March, 1954.

## V.

That no one, by the authority of the plaintiffs, orally stated that the \$9.00 per cwt., including bag, price, quoted for the popcorn in the May 11th contract would be reduced to \$8.00.

## VI.

That any such oral statement, if made, would not be enforceable for the reason that the same is in violation of the Statute of Frauds of the Uniform Sales Act, ORS Sec. 75.040.

VII.

That any such oral statement would also be unenforceable for the reason that no consideration was given to support any promise implicit in such a statement to sell the corn for a price lower than that expressed in the contract.

VIII.

The plaintiffs deny each contention of the defendant.

Defendant's Contentions

I.

That plaintiffs are not the real parties in interest and not proper parties to the complaint, in that the proceeds of any such claims as this have been set over to creditors of the plaintiff by the United States District Court for the Eastern District of Illinois in a proceeding for an arrangement filed by the plaintiffs herein and bearing file No. 4028-D. (Reference Exhibits XVI, XVII, XVIII and XIX.)

II.

Plaintiffs' complaint fails to state a cause of action in that it does not seek to enforce any of the remedies to which plaintiff is limited by the contract.

III.

That plaintiffs were not able to ship to the defendant, popcorn of the kind and quality referred to in said contract at the times therein provided for.

## IV.

That the plaintiff and defendant mutually rescinded the contract of May 11, 1953, and mutually agreed to enter into a contract at price of \$8.00 per hundred pounds; and that the defendant fully complied with all terms of the said contract, by ordering from the plaintiff all of the corn covered by the said contract, but the plaintiff breached the said contract, by ignoring the aforesaid orders from this defendant, and by failing to ship any corn to the defendant.

## V.

That the plaintiff and defendant mutually agreed to revise the said contract of May 11, 1953, by reducing the price thereon from \$9.00 to \$8.00 per 100 lb. bag of corn, f.o.b. Watseka, Illinois; that the defendant fully complied with the mutually revised contract by ordering 3,600 100-pound bags of corn from the plaintiff at \$8.00 per 100-lb. bag, but the plaintiffs breached the said mutually revised contract by ignoring the aforesaid orders from the defendant, and by failing to ship the defendant any corn whatsoever.

## VI.

By holding the contract in abeyance (Exhibit III) until the end of December (Exhibit V), plaintiffs waived any right to enforce performance of the contract as to the first three months thereof or as to 1,800 bags. Plaintiffs' damages, if any, are limited to the balance of the contract, being three months shipments or 1,800 bags.

VII.

Under the doctrine of mitigation of damages, plaintiffs were required to accept defendant's offer to purchase corn at \$8.00, and if plaintiffs are entitled to any damages, they are limited to \$1.00 per bag.

VIII.

Defendant denies each contention of plaintiffs.

Issues

I.

In what amount, if any, is the defendant liable to the plaintiffs?

Exhibits

Exhibit No.

- I. Described in admitted fact 4.
- II. Described in admitted fact 6.
- III. Described in admitted fact 9.
- IV. Described in admitted fact 10.
- V. Described in admitted fact 12.
- VI. Described in admitted fact 13.
- VII. Described in admitted fact 14.
- VIII. Described in admitted fact 15.
- IX. Described in admitted fact 17.
- X. Described in admitted fact 18.
- XI. Described in admitted fact 19.
- XII. Described in admitted fact 20.
- XIII. Described in admitted fact 11.
- XIV. Described in admitted fact 21.
- XV. Described in admitted fact 22.

- XVI. Original Arrangement proposed by Debtors, dated July 1, 1955.
- XVII. Order pertaining to above Arrangement, dated August 17, 1955.
- XVIII. Amended Arrangement, dated September 10, 1955.
- XIX. Order confirming Amended Arrangement, dated September 27, 1955.

It Hereby Is Ordered that the foregoing constitutes the pre-trial order in the above cause and that it supersedes the pleadings and that said pre-trial order should not be amended during the trial except by consent or by order of the Court to prevent manifest injustice.

Dated this 4th day of December, 1956.

/s/ CLAUDE McCOLLOCH,  
United States District Judge.

The foregoing form of pre-trial order is hereby approved.

/s/ JOHN F. REYNOLDS,  
Of Attorneys for Defendant.

/s/ WILLIAM E. TASSOCK,  
Of Attorneys for Plaintiffs.

Lodged May 21, 1956.

[Endorsed]: Filed December 4, 1956.



[Title of District Court and Cause.]

STIPULATION

It Is Stipulated and Agreed between the parties hereto, acting through their attorneys, that the Exhibits marked I through XIX, which Exhibits are attached hereto, are genuine and what they purport to be, are either the originals or true copies thereof, and that all or any of said Exhibits may be, without objection detached from this Stipulation, and introduced into evidence by either party at the time of the trial of the above case, except that plaintiffs reserve the right to object to the relevancy of Exhibits XVI, XVII, XVIII and XIX.

/s/ WILLIAM E. TASSOCK,  
Of Attorneys for Plaintiffs.

/s/ JOHN F. REYNOLDS,  
Of Attorneys for Defendant.

---

[Title of District Court and Cause.]

PLAINTIFFS' REQUESTED INSTRUCTIONS

I.

It is admitted that plaintiffs and defendant entered into the contract of May 11, 1953. It is also admitted that the defendant did not order any popcorn at the \$9.00 price as provided in the contract.

The defendant, as a matter of law, has not established that the \$9.00 price stated in the contract was

lowered, nor has the defendant established that the contract was rescinded.

You are therefore instructed to find your verdict for the plaintiffs if you find that the plaintiffs were ready, willing and able to perform their duties under the contract.

The amount of the verdict is to be determined from the instructions that I give you concerning the measure of damages and the evidence pertaining to damages presented in this case.

Authority:

The price of chattels agreed upon in a contract within the statute of frauds cannot be modified by a subsequent oral agreement.

Osborn v. Deforce,  
122 Or. 360, 257 P. 685.

“Williston on Contracts,”  
Sec. 593, N. 1, p. 1705.

“Williston on Sales,”  
Sec. 71 (d).

A.L.I. Rest. of Law of Contracts,  
Sec. 223(2).

See Cases collected, 17 ALR 9, 29 ALR 1095,  
80 ALR 539, 118 ALR 1511. [5]

True a contract within the statute may be orally rescinded; however, there is no evidence that these parties intended to rescind the original contract unless this intention is to be presumed, as a matter

of law, from the evidence that the parties entered into a subsequent oral agreement changing the terms of the original contract. If this presumption exists, the rule prohibiting oral modification of contracts within the statute does not exist, because such a presumption would operate in every case. Furthermore, according to Williston on Contracts, Section 593, an oral rescission which is to be effected only as a part of an entire agreement to substitute a new oral agreement is ineffective. There is no writing signed by the plaintiffs evidencing the alleged contract.

## II.

(Requested in the event No. 1 above is refused.)

The defendant, as a defense to plaintiffs' action, is contending that the parties agreed to lower the price provided in the contract of May 11, 1953, and that plaintiffs failed to perform this agreement.

In view of the evidence presented in this case and the law applicable thereto, I instruct you that any such agreement is no defense to plaintiffs' claim.

Authority:

The price of chattels agreed upon in a contract within the statute of frauds cannot be modified by a subsequent oral agreement. Dozens of cases collected in 17 A.L.R. 9, 29 A.L.R. 1095, 80 A.L.R. 539, 118 A.L.R. 1511, and A.L.I. Rest. of Law of Contracts, Sec. 223(2).

True a contract within the statute may be orally rescinded; however, there is no evidence that these

parties intended to rescind the original contract unless this intention is to be presumed, as a matter of law, from the evidence that the parties entered into a subsequent oral agreement changing the terms of the original contract. If this presumption exists, the rule prohibiting oral modification of contracts within the statute, does not exist, because such a presumption would operate in every case.

There is no writing signed by the plaintiffs evidencing the alleged contract.

### III.

If you find that the time of delivery of the popcorn stipulated in the original contract of May 11, 1953, was extended for an indefinite time by the mutual consent of the parties and for their mutual benefit, or as the result of leniency by the seller, or at the request of the buyer, and you also find that the plaintiffs later requested that defendant take shipment and that the defendant refused and repudiated the contract, clearly indicating his intention not to perform it, the damage to the plaintiffs is the difference between the contract price and the market price at the time defendant, by his conduct, indicated that he refused to take delivery of any corn under the contract of May 11, 1953, and repudiated the contract.

Authority:

Where the delivery time stated in a contract is, by mutual consent or acquiescence of the buyer, or

leniency of the seller, extended for an indefinite period, the measure of damages for buyer's failure to buy is the difference between the contract price and the market price at the time and place of the buyer's refusal to accept delivery in response to seller's demand that he do so.

Vol. 2, Williston on Contracts,  
Sec. 596 N. 1.

Kutztown Foundry & M. Co. v. Sloss-Sheffield S. & I. Co., 279 F. 627.

James River Lumber Co. v. Smith Bros.,  
116 S.E. 241.

News Pub. Co. v. Denison-Pratt,  
117 S.E. 920.

Fitchbury Yarn Co. v. Hope Webbing Co.,  
127 A. 148.

Teuscher v. Utah-Idaho Flour & Grain Co.,  
221 P. 1096.

#### IV.

If you find that the defendant did not consent to an extension of the time for shipment or delivery of the popcorn as such times are stated in the contract, and if you find that the defendant simply refused to take delivery of any popcorn at the price stated in the contract and at the times stated in the contract, the damage to the plaintiffs is the difference between the contract price and the market price prevailing at the times stated in the contract.

In this connection I call to your attention the



fact that it is admitted in this case that the defendant was under no obligation to take any corn the last six months stated in the contract.

### V.

(Requested in the event numbers III and IV are refused)

If you determine from the evidence and the instructions that I have previously given you that the defendant is liable to the plaintiffs, you must then proceed to determine plaintiffs' damages, if any.

If you find in seeking to determine plaintiffs' damages, if any, that the time of delivery of the popcorn stipulated in the original contract of May 11, 1953, was extended for an indefinite time by the mutual consent of the parties and for their mutual benefit, or as the result of leniency by the seller, or at the request of the buyer, and you also find that the plaintiffs later requested that defendant take shipment and that the defendant refused and repudiated the contract, clearly indicating his intention not to perform it, the damage to the plaintiffs is the difference between the contract price and the market price at the time defendant, by his conduct, indicated that he refused to take delivery of any corn under the contract of May 11, 1953, and repudiated the contract.

If, however, in seeking to determine plaintiffs' damages, if any, you find that the defendant did not consent to an extension of the time for shipment or delivery of the popcorn as such times are

stated in the contract, and if you find that the defendant simply refused to take delivery of any popcorn at the price stated in the contract and at the times stated in the contract, the damage to the plaintiffs is the difference between the contract price and the market price prevailing at the times stated in the contract.

In this connection I call to your attention the fact that it is admitted in this case that the defendant was under no obligation to take any corn the last six months stated in the contract.

(Note: See authorities under III, *supra*.)

---

[Title of District Court and Cause.]

DEFENDANT'S REQUESTED  
INSTRUCTIONS

The defendant respectfully requests the court to instruct the jury as follows: [6]

Defendant's Requested Instruction No. ....

A written contract may be rescinded and superseded by a new contract by the express or implied agreement of the parties, and, likewise, a written contract may be modified by subsequent agreement of the parties.

This rescission or modification may be oral or partly oral and partly written, even though the original contract be in writing. Therefore if you

find that the plaintiffs' letter of October 23, 1953, and the oral conversations of the parties, either taken separately or considered together, amounted to a rescission of the original contract and the making of a new contract at a price of \$8.00, or a modification of the old contract so that the price was changed to \$8.00, then you must find your verdict against the plaintiffs and for the defendant, for it is uncontradicted that defendant offered to buy corn at \$8.00.

Dorsey v. Tisbey,  
192 Or. 163, 173.

Wyllie China Co. v. Venton,  
97 Or. 350, 363-4.

Defendant's Requested Instruction No. ....

With respect to a contract for future delivery of merchandise, the rule of general damages is that on refusal of the buyer to take the property, the seller is entitled to recover the difference between the contract price and the lesser market value of the goods at the time and place of delivery. Therefore if you find that the original contract was neither rescinded nor modified, and that the defendant breached the contract, then the maximum amount which plaintiff would be able to recover would be the difference between the contract price of \$9.00 per hundred pound bag and the market price during October, November and December, 1953, and January, February and March, 1954, computed on 600 bags for each of those months, ~~except, however,~~

~~that plaintiff was required to mitigate his damages, as stated in other instructions.~~

Rose v. U. S. Lumber & Box Co.,  
108 Or. 237, 248, 215 Pac. 171.

Defendant's Requested Instruction No. . . . .

The law imposes upon a party injured by another's breach of contract the active duty of using all ordinary care and making all reasonable exertions to render the injury as light as possible. Therefore, if you find that the defendant made a bona fide offer to buy corn at \$8.00 per bag, then that may be taken into your consideration in assessing damages, if you find that plaintiff is entitled to any damages. Thus if you find that defendant was required to accept 1,800 bags, or 3 monthly installments, under the contract, plaintiff's damages would therefore be limited to \$1.00 per bag, or \$1,800.00. If you find that defendant was required to accept 3,600 bags, then the damages, under this theory, would amount to \$3,600.00.

Stillwell v. Hill,  
87 Or. 112, 123, 126, 169 Pac. 1174.

Borden & Cox v. Vinegar Bend Lumber Co.,  
2 Ala. App. 354, 56 So. 775.

Caulter v. B. F. Thompon Lbr. Co.,  
142 Fed. 706.

Arkansas & T. Grain Co. v. Young,  
96 S.W. 142 (Ark.).

## Defendant's Requested Instruction No. . . . .

If you find that the original contract was neither modified nor rescinded, then you must consider the quantity of corn which defendant was required to accept under the original contract. The words "in abeyance" as used in plaintiffs' letter of October 23, 1953, mean: "Temporarily inactive, suspended or suppressed; temporarily without manifest existence" or "a condition of being undetermined." Since the plaintiffs' letter terminating the period of abeyance did not reach defendant until the time for performance had passed as to the first three months, you must limit your consideration of damages to the last 3 cars, or 1,800 bags of corn.

Webster's New International Dictionary, 2nd Add., 1 Words and Phrases 75, citing *Fenn v. Amer. Rattan & Reed*, 130 N.E. 129, 75 Ind. App. 146.

If the Court declines to give the above-requested instruction, then defendant requests the following instructions:

If you find that the original contract was neither modified nor rescinded, and if you do not limit plaintiffs' damages to \$1.00 per bag, then you must consider the measure of damages based on market value, and since the market price was falling, it will make a difference as to what months you use. In this connection I instruct you that when plaintiff notified defendant that the contract could no longer remain in abeyance, the legal effect of this was to



place the parties back in their original position. and you should start with the market price in October, 1953, and use the market price for each succeeding month to compute the damages as to each 600-bag car.

Clayton Oil Refining Co., v. Langford,  
293 S.W. 559.

Stillwell v. Hill,  
87 Or. 112, 126.

---

In the United States District Court  
for the District of Oregon

Civil No. 8500

**HAROLD M. ALVER, OSCAR J. ALVER, RAY-  
MOND N. ALVER, LUCILE M. ALVER,  
JEANNETTE B. ALVER and MILDRED  
M. ALVER, a Co-partnership Doing Business  
as PREMIER POPCORN COMPANY,**

Plaintiffs,

vs.

**H. P. WILLMAN, Doing Business as POPPERS  
SUPPLY CO.,**

Defendant.

**JUDGMENT**

The above-entitled action having come on regularly for trial before the undersigned Judge of the

above-entitled Court on this 5th day of December, 1956, plaintiff, Harold M. Alver, appearing in person and by his attorney of record, William E. Tassock, and the defendant appearing in person and by his attorneys, J. P. Stirling and John F. Reynolds; and after the jury was duly impanelled and sworn, opening statements were heard and evidence and exhibits were offered by both parties, arguments being made by counsel, at the conclusion of which the Court duly instructed the jury, and on the 5th day of December, 1956, the jury returned its verdict reading as follows, title and caption omitted:

“We, the jury in the above-entitled matter, find our verdict for the plaintiffs in the sum of \$10,800.00.

“Dated at Portland, Oregon, this 5th day of December, 1956.

“SALLY CARPENTER,  
“Foreman.”

and the verdict was duly filed in the above-entitled cause upon which the plaintiffs moved for a judgment.

Now, Therefore, It Is Considered, Ordered and Adjudged that the plaintiffs have and recover of said H. P. Willman, doing business as Poppers Supply Co., the sum of \$10,800.00, together with plaintiffs' costs and disbursements incurred herein amounting to the sum of \$121.35.

Dated this 5th day of December, 1956.

/s/ CLAUDE McCOLLOCH,  
Judge.

[Endorsed]: Filed December 10, 1956. [7]

---

[Title of District Court and Cause.]

NOTICE OF APPEAL

To the above-named plaintiffs, Harold M. Alver, Oscar J. Alver, Raymond N. Alver, Lucile M. Alver, Jeannette B. Alver and Mildred M. Alver, and to W. E. Tassock, and Clark & Clark, their Attorneys:

Notice is hereby given that H. P. Willman, defendant above named, hereby appeals to the United States Court of Appeals for the Ninth Circuit, from the final judgment entered in this action in the United States District Court for the District of Oregon, on December 5, 1956.

Dated at Portland, Oregon, this 3rd day of January, 1957.

/s/ J. P. STIRLING,  
Of Attorneys for Defendant.

Service of copy acknowledged.

[Endorsed]: Filed January 3, 1957. [11]

[Title of District Court and Cause.]

UNDERTAKING ON APPEAL  
SUPERSEDEAS

Whereas, H. P. Willman, doing business as Poppers Supply Co., in the above-entitled action, appeals to the United States Court of Appeals for the Ninth Circuit from a judgment made and entered against the defendant in the said action in the District Court, in favor of the plaintiffs in the said action and against the defendant on the 5th day of December, 1956, for Ten Thousand Eight Hundred and No/100 Dollars (\$10,800.00) damages, and Sixty-two and 20/100 Dollars (\$62.20) costs and disbursements.

Now, Therefore, in consideration of the premises, and of such appeal, the undersigned, the Fidelity and Deposit Company of Maryland, of Baltimore, Maryland, a corporation organized and empowered under the laws of the State of Oregon to become surety upon bonds, undertakings, etc., in the State of Oregon, does hereby jointly and severally undertake and promise, on the part of the appellant, that the appellant will pay all damages, costs and disbursements which may be awarded against it on appeal,

And, Whereas, the appellant is desirous of staying the execution of the said judgment so appealed from, it does further, in consideration thereof, and of the premises, jointly and severally undertake and promise that if the said judgment appealed

from, or any part thereof, be affirmed, the appellant will satisfy it so far as affirmed.

[Seal] THE FIDELITY AND DEPOSIT COMPANY OF MARYLAND,

By /s/ ROBERT B. CUMMING,  
Attorney-in-Fact and  
Resident Agent.

/s/ CLAUDE McCOLLOCH,  
Chief Judge.

[Endorsed]: Filed January 4, 1957. [12]

---

[Title of District Court and Cause.]

### ORDER

This matter coming on regularly for hearing upon the motion of the defendant for an Order authorizing and directing the Clerk of this Court to transmit to the United States Court of Appeals for the Ninth Circuit, all of the Exhibits introduced at the trial of the above-entitled cause, and it appearing to the Court that it is impracticable to print said Exhibits and the Court being fully advised,

It Is Hereby Ordered that the Clerk of the United States Court for the District of Oregon be and he hereby is authorized and directed to transmit to the United States Court of Appeals for the Ninth Circuit, all of the Exhibits introduced at the trial of the above-entitled cause.



Dated in open Court this 9th day of January,  
1957.

/s/ CLAUDE McCOLLOCH,  
Judge.

[Endorsed]: Filed January 9, 1957. [14]

---

United States District Court  
District of Oregon  
Civil No. 8500

HAROLD M. ALVER, OSCAR J. ALVER, RAY-  
MOND N. ALVER, LUCILE M. ALVER,  
JEANNETTE B. ALVER and MILDRED M.  
ALVER, a Co-partnership Doing Business as  
PREMIER POPCORN COMPANY,

Plaintiffs,

vs.

H. P. WILLMAN, Doing Business as POPPERS  
SUPPLY CO.,

Defendant.

Before: Honorable Claude McColloch, Chief Judge.

Appearances:

WILLIAM E. TASSOCK,  
Of Attorneys for Plaintiffs.

JOHN F. REYNOLDS, and  
J. P. STIRLING,  
Attorneys for Defendant.

TRANSCRIPT OF PROCEEDINGS

December 4, 1956

(A jury was duly and regularly empaneled and sworn, counsel for the respective parties made opening statements to the jury, and thereafter the following occurred:)

HAROLD M. ALVER

one of the Plaintiffs herein, was produced as a witness in behalf of Plaintiffs and, having been first duly sworn, was examined and testified as follows:

Direct Examination

By Mr. Tassock:

Q. Mr. Alver, you are one of the plaintiffs in this action, aren't you?           A. Yes; I am.

Q. Where do you reside, sir?

A. In Watseka, Illinois.

Q. Where is Watseka, Illinois?

A. About 100 miles south of Chicago, in the farming area, in the corn belt of Illinois.

Q. What is your occupation?

A. Popcorn processor.

Q. Popcorn processor?           A. Yes.

Q. With whom are you employed?

A. We are six partners, three brothers and their wives, or six altogether. [2\*]

Q. It has been stipulated in this case that you do business in Illinois under the name of Premier Popcorn Company. Now, how long have you been engaged in this occupation as a processor?

---

\*Page numbering appearing at top of page of original Reporter's Transcript of Record.

(Testimony of Harold M. Alver.)

A. Over twenty years.

Q. Could you describe for the jury what the nature of the Premier Popcorn Company's operations were in 1953 and '54. How did you carry on business?

A. We were operating as a popcorn processing plant. In the spring of the year we went out to various farmers and contracted with them for acreage of popcorn to be grown during the summer months and delivered to us in the fall of the year at a fixed price. At the same time in the spring of the year, while we were contacting these farmers, we were also contacting our customers and selling them corn under a contract for delivery to start in the fall of the year at the same time that the farmers were harvesting and bringing us the crop.

Mr. Tassock: It has been stipulated here in the pretrial order, your Honor, that on or about May 11, 1953, the defendant contracted in a writing which has been marked as Plaintiff's Exhibit 1 to buy 7,200 100-pound bags of S. A. Yellow Hybrid Variety "Golden Rocket" popcorn for the sum of \$9.00 per 100 pounds, and that the plaintiffs prior to May 21, 1953, also signed Exhibit No. 1 and agreed to sell this popcorn. [3]

At this time I would like to offer into evidence Plaintiffs' Exhibit No. 1.

The Court: Admitted.

(The sales contract referred to, dated May 11, 1953, was received in evidence as Plaintiffs' Exhibit 1.)

(Testimony of Harold M. Alver.)

Mr. Reynolds: The only thing I would like to call the Court's attention to is it shows on its face plus 25 cents for bags per 100 pounds. Otherwise, no objection.

Q. (By Mr. Tassock): Mr. Alver, Plaintiffs' Exhibit 1, the contract, refers to S. A. Yellow Hybrid Corn. I wonder if you would tell the jury what that is?

A. S. A. Yellow Hybrid Corn means a South American variety, which is a large grain yellow popcorn as distinguished from white hull-less, white grain popcorn.

Mr. Tassock: I wonder, your Honor, if at this time we could take the time to have the jury read this contract.

The Court: Not now. You can read these things later.

Q. (By Mr. Tassock): The contract bears the signature or purports to bear the signature of Mr. Herman Willman. Were you present when he signed it? A. Yes; I was.

Q. Where did that take place?

A. In Portland, in his office.

Q. Did Mr. Willman read the contract before signing it? [4] A. Yes; he did.

Q. I am going to read a part of the exhibit which pertains to the time of the shipment for the 7,200 bags covered by the contract. It says: "Time of shipment. Quantity, 600; time, October, 1953; quantity, 600, November, 1953; 600, December, 1953; 600, January, 1954; 600, February, 1954; 600, March,

(Testimony of Harold M. Alver.)

1954; 600, April, 1954; 600, May, 1954; 600, June, 1954; 600, July, 1954; 600, August, 1954; and 600 in September, 1954.”

Now, this was signed in May. Was this one of those contracts where you agreed to sell corn that had not been grown?       A. Yes.

Q. You also at that time had contracted with the farmer to buy the corn?

A. Yes; we had. At the same time we were contracting with farmers at a definite price.

Q. Now, at the time this contract was signed here in Portland, were there any discussions between you and Mr. Willman concerning any terms or conditions that are not stated in Plaintiffs' Exhibit 1?

A. Mr. Willman agreed to the deal and signed the contract. However, he asked that he be given an option to cancel the last six cars of corn if he wished to do so at a later date. I told Mr. Willman that I would discuss that with my partners and let him know, which I did, and I wrote him a letter at a [5] later date giving him the privilege of canceling the last six cars, starting in April.

Mr. Tassock: It is stipulated here that on May 20th, 1953, Mr. Alver wrote and subsequently the defendant received a letter which has been marked as Plaintiffs' Exhibit No. 2. I would like to ask at this time that this letter be introduced into evidence.

Mr. Reynolds: We have no objection, your Honor.

The Court: Admitted.



(Testimony of Harold M. Alver.)

(The letter referred to, dated May 20, 1953, was received in evidence as Plaintiffs' Exhibit 2.)

Mr. Tassock: If I may, your Honor, I would like to read this letter because it bears on just what we have been talking about.

The Court: You have already stated what is in there. You don't need to read it now. They know what it is. It confirms the privilege to cancel the last six cars.

Mr. Tassock: Yes; that is the letter confirming that he could cancel the last six cars.

Q. Was the 1953 crop of corn delivered to you as agreed by the farmers?

A. Yes; the farmers grew the crop and delivered to us in the fall of the year approximately 20,700,000 pounds of popcorn. [6]

Q. How much?

A. 20,700,000 pounds of shelled popcorn.

Q. It is stipulated here that after this letter of May 20th, which is Plaintiffs' Exhibit No. 2, your next contact of any kind with Mr. Willman here was about October 12th, 13th or 14th of 1953 in Chicago. What was the occasion for this meeting?

A. It was at a popcorn convention.

Q. Did you see and talk with Mr. Willman there? A. Yes; I did.

Q. Do you recall if the May, 1953, contract was discussed? A. Yes; it was.

(Testimony of Harold M. Alver.)

Q. Do you recall the nature of these discussions?

A. Shortly before the convention time the open market price of popcorn had dropped below the \$9.00 contract price to about \$8.00, and Mr. Willman asked me to give him some relief on that \$9.00 contract price.

Q. Would you speak louder, please?

A. I told Mr. Willman I was surprised at his asking me for a price reduction on that contract, since we had just completed delivery of a year's supply of corn to him at a price of \$9.00 at a time when the market price was \$12.50, and that on the very first car of corn in October I didn't feel that we should immediately have to give him a price reduction because the market happened to drop below the [7] \$9.00 price. He insisted, however, that I give him some relief, and I told him that I would go back to my partners in Watseka and discuss the matter with them and see if there was anything we could do for him, which I did.

Q. Was there anything else that was discussed at that time about changing the contract that you can remember?      A. I believe not.

Q. Now, it is stipulated here that after the popcorn convention your next contact with Mr. Willman was on or about October 23rd 1953, where a long-distance telephone conversation was had when you were in Watseka, Illinois, and Mr. Willman when he was in Portland. Now, do you recall that the contract of May 11th, 1953, was discussed during

(Testimony of Harold M. Alver.)

that conversation?           A. Yes; it was.

Q. Do you remember the general nature of what was said?

A. I called Mr. Willman regarding delivery of a car of corn that was left over from the previous year's contract. It was a car of corn that had sold to him for \$12.50 in addition to his regular contract corn, and he asked me for a reduction in price on that particular car of corn. I gave him a \$2.00 reduction because of the fact we were already in the new crop of corn and we were getting the new crop of corn cheaper. And then he asked me for a reduction on the May 11th contract from \$9.00 to \$8.00, which I refused to give him. However, I [8] told him that if he wanted to buy some \$8.00 open market corn we would hold up delivery on the contract corn for the time being and sell him some \$8.00 open market corn.

Q. Did he indicate that this was agreeable to him?

A. Yes; he felt that that would give him some relief.

Mr. Tassock: It is stipulated here that on October 23rd, 1953, you wrote and mailed to Watseka, Illinois, a letter which has been marked as Plaintiffs' Exhibit No. 3, which was received in due course by the defendant. I would like to offer and read this letter, your Honor.

The Court: Let's not read any letters so long as you can tell them what it is. It is admitted.

(Testimony of Harold M. Alver.)

(The letter referred to, dated October 23, 1953, was received in evidence as Plaintiffs' Exhibit 3.)

The Court: You tell them the subject of it if you think he has not explained it fully.

Q. (By Mr. Tassock): In that letter you confirm or purport to confirm the conversation, the telephone conversation—you referred to a telephone conversation in the letter. What I want to know is is that letter the same telephone conversation that you have just told the jury about? A. Yes.

Q. And in that letter you indicate that you will hold the contract in abeyance and sell him \$8.00 corn on the open [9] market. Was that letter written in response to Mr. Willman's request here for some relief on the 1953 contract?

A. Yes. He said he couldn't take any \$9.00 corn because of the market situation, and we made this offer to him, knowing that he would use more corn than was on the contract during the year, and if it would help him any we were glad to hold up delivery of the contract corn for a short time and sell him some \$8.00 corn on the market.

Mr. Tassock: At a later point, your Honor, I am going to ask the Court to judicially note the meaning of the word "abeyance" as it appears in that letter.

Q. Now, it is stipulated that your next communication with Mr. Willman was at a meeting that

(Testimony of Harold M. Alver.)

you had with him in Portland, Oregon, in November of 1953. Do you recall the occasion for that meeting?

A. Yes. Mr. Willman complained on the quality of some corn we had shipped him, claiming that there was some white corn mixed in with it, and I came out to examine the corn. This was on the previous car on the last year's contract.

Q. That was the car of corn that was on the previous year's contract and had nothing to do with this year's contract?      A. That is right.

Q. Was the May 11th, 1953, contract, Plaintiffs' Exhibit No. 1, discussed at this time in November?

A. Yes; it was. [10]

Q. Do you recall what was said and by whom?

A. Mr. Willman asked me for a price reduction in the contract. He wanted me to ship him some of the contract corn at \$8.00 instead of \$9.00, which I refused to do. I still said that he could buy some \$8.00 open market corn if he wished. However, we insisted that he take out the 3,600 bags at \$9.00 on the contract corn.

Q. Did you at that or any other time tell Mr. Willman that the contract price stated in Exhibit No. 1 would be lowered from \$9.00 per hundred-weight, which includes the bag, to \$8.00 per hundred-weight, including the bag?      A. No; I did not.

Mr. Tassock: Now, it is stipulated that the next contact between you and Mr. Willman was a letter which has been marked here as Plaintiffs' Exhibit No. 4, which was written and mailed by the defendant in Portland, Oregon, on December 15th, 1953.



(Testimony of Harold M. Alver.)

This is a letter where he exercises the right to cancel the last six cars under the contract. The defendant wrote this letter to the plaintiff. I will offer this into evidence.

Mr. Reynolds: We have no objection.

The Court: Admitted.

(The letter referred to, dated December 15th, 1953, was received in evidence as Plaintiffs' Exhibit 4.) [11]

Mr. Tassock: It is further stipulated that the next communication between the plaintiffs and the defendant was a letter which is here marked as Plaintiffs' Exhibit 8. I wonder if I could have this number changed. It was already marked, your Honor, but I would like to have it remarked, if possible, so that we can keep the exhibits with the same numbers as in the pretrial order. Will you mark this as No. 5, please.

I started to say it is further stipulated here that the next communication between the plaintiffs and the defendant was a letter which has been marked here as Plaintiffs' Exhibit 5, which was written and mailed by the plaintiffs in Watseka, Illinois, on December 16, 1953. This letter is a letter where the plaintiffs inform the defendant that the company is going through an arrangement in the Federal Bankruptcy Court and that he knows the defendant is going to hear about it, and he wants him to know that they are still financially able to carry on business and still have their crop under control.

(Testimony of Harold M. Alver.)

This will be read to you at a later date more fully.

Mr. Reynolds: I wonder, Mr. Tassock, if that shouldn't be No. 13 instead of No. 8. It is so marked here. I think that, following the pretrial numbering system, it should be 13. [12]

Mr. Tassock: You are right. With the Court's permission, I would like to change the number to No. 13.

Mr. Reynolds: It has two numbers on it, but the number at the bottom is 13. That is the right number.

Mr. Tassock: That is Plaintiffs' Exhibit 13.

The Court: Admitted.

(The letter referred to, dated December 16, 1953, was received in evidence as Plaintiffs' Exhibit 13.)

Mr. Tassock: It is stipulated here that the next communication between these parties was a letter marked as Plaintiffs' Exhibit 5, written by the plaintiff on December 22nd, 1953. It was mailed on January 2nd, 1954, and was received by the defendant here on January 4th, 1954. This is a letter where the plaintiffs notified the defendant that they are not going to hold this contract in abeyance any longer, and they insist that the defendant order some corn at the \$9.00 contract price.

Mr. Reynolds: We have no objection. I might note, however, that attached to it is an invoice from the plaintiffs. That is attached to the letter.

The Court: Admitted.

(Testimony of Harold M. Alver.)

(The letter referred to, with attached invoice, was received in evidence as Plaintiffs' Exhibit 5.) [13]

Q. (By Mr. Tassock): Do you recall that letter, Mr. Alver?      A. Yes; I do.

Q. What circumstances prompted the writing of that letter?

A. We had received no shipping instructions whatsoever from Mr. Willman on either the \$9.00 contract corn or had he given any purchase order for any open market \$8.00 corn, and we felt we had waited long enough and we sent him that letter telling him we were no longer interested in selling any open market corn; that we wanted him to start taking out his contract corn.

Q. What happened after you sent the letter, Exhibit No. 5?

A. I had a telephone call from Mr. Willman on January 5th.

Q. Do you remember what was said, if anything, pertaining to this contract of May 11th?

A. Yes. Mr. Willman said that he would not pay \$9.00 for any corn. And I said that we were going to insist that he pay \$9.00 for that corn and start taking it out. He told me I could keep my damned corn and sue them and he would drag me through the courts for two or three years.

Q. It is stipulated here that on January 5th you wrote and mailed to the defendant a letter marked Plaintiffs' Exhibit 6. I would like to offer this letter

(Testimony of Harold M. Alver.)

into evidence, which is a letter where the plaintiffs asked the defendant to put his position in writing; that he wanted the defendant to write the plaintiff and put his position in this matter in [14] writing.

What, if any, was the connection between this letter and the telephone conversation on that same day?

A. Well, at the time of the telephone conversation we were acting as debtors in possession dealing with the Federal Court, and I wanted something in writing from Mr. Willman on the position he was taking so that when I talked to the Court I could explain to them and show them where there would evidently be some litigation.

Mr. Tassock: I offer that in evidence.

Mr. Reynolds: We have no objection, your Honor.

(The letter referred to, dated January 5, 1954, was received in evidence as Plaintiffs' Exhibit 6.)

Mr. Tassock: It has been stipulated that on January 11th, 1954, the plaintiffs received in the mail at Watseka, Illinois, the defendant's Purchase Order No. 1856, which has been marked here as Plaintiffs' Exhibit No. 8. This is a purchase order where the defendant ordered two cars of popcorn at the price of what amounts to \$8.00 in Watseka, Illinois, and says not to ship him any corn under any other conditions. I offer this into evidence.

(Testimony of Harold M. Alver.)

Mr. Reynolds: You mentioned No. 8, Mr. Tassock. I think that should be No. 7, shouldn't it?

Mr. Tassock: These exhibits have so many numbers on [15] them from prior trials. It should be Plaintiff's Exhibit No. 7.

Mr. Reynolds: We have no objection, your Honor.

(The purchase order above referred to, dated January 5, 1954, was received in evidence as Plaintiffs' Exhibit 7.)

Mr. Tassock: It is stipulated that prior to January 28, 1954, the plaintiffs retained an attorney here in Portland by the name of Malcolm Clark to represent them, and that on January 28, 1954, the plaintiffs' attorney wrote the defendant a letter which is marked as Plaintiffs' Exhibit No. 8, and it was sent to the defendant, who received it in due course of mail. In this letter the attorney notified the defendant that the plaintiff is going to insist that he perform the contract; that is, that the defendant perform the contract to buy the \$9.00 corn, and advised him that the purchase order which has been marked as Plaintiffs' Exhibit 7 is not acceptable under the contract and is not acceptable as an order under the contract.

We would like to offer this letter into evidence.

Mr. Reynolds: We have no objection.

(The letter referred to, dated January 28, 1954, was received in evidence as Plaintiffs' Exhibit 8.)



(Testimony of Harold M. Alver.)

Mr. Tassock: It is stipulated also that on January 28, [16] 1954, the plaintiff wrote the defendant a letter which is marked here as Plaintiffs' Exhibit No. 9, where the plaintiff informed the defendant that Mr. Clark was representing him.

I will offer that letter into evidence.

Mr. Reynolds: We have no objection, your Honor.

(Copy of letter referred to, dated January 28, 1954, was received in evidence as Plaintiffs' Exhibit 9.)

Mr. Tassock: Now, we come to February 2nd, 1954, and we have stipulated that on that date the defendant signed and mailed to the plaintiff another purchase order which has been marked as Plaintiffs' Exhibit No. 11. This purchase order, once again, is an order for popcorn at the \$8.00 price.

Mr. Reynolds: We have no objection to that, your Honor.

(Photostatic copy of the purchase order referred to, dated February 2, 1954, was received in evidence as Plaintiffs' Exhibit 11.)

Q. (By Mr. Tassock): Mr. Alver, we have introduced into evidence here two purchase orders. Did you receive any other purchase orders from the defendant pertaining to this contract of May 11th, 1953? A. No; I did not. [17]

Q. You never received any other orders to this present day under that contract?

A. That is right.

(Testimony of Harold M. Alver.)

Q. Did you ship any popcorn in response to these orders?      A. No; I didn't.

Q. One matter I would like to go back to. In your letter of December 22nd, which has been marked here—I forget the number—anyway, in one of these letters you stated, "We hold for you at our plant and to your account 1800 bags of Golden Rocket popcorn guaranteed to pop 30 to 1 or better." You say that in a letter to Mr. Willman. Would you explain to the jury and to the Court what you meant by that. That is, what do you actually do in your plant?

A. We kept our corn on the cob and on the shelled basis ready to bag out as we received orders. The corn would be on a shelled basis in bins ready to bag out, and we had marked our records showing that Mr. Willman was in arrears three cars of corn or 1800 bags at that time.

Q. In other words, you just marked it on your records?      A. Yes.

Q. But there was no segregation of any corn that was actually set aside, where you said "This is Mr. Willman's popcorn"?      A. No.

(Short recess.) [18]

Q. (By Mr. Tassock): Mr. Alver, what is your background and experience pertaining to the market value of popcorn in Watseka, Illinois, during the years 1953 and '54?

Mr. Reynolds: If it please the Court, we will

(Testimony of Harold M. Alver.)

stipulate that he is an expert and qualified to testify as to the market price at the times concerned.

Mr. Tassock: Very well.

Q. Did you make an investigation to determine the market value of popcorn of the kind and quality described in the contract of May 11th, 1953?

A. Yes; I did.

Q. At Watseka, Illinois, during the years '53 and '54?

A. Yes; I did. I checked my records and I checked with other brokers and the larger buyers in the country as to the market price during that time.

Q. Have you formed an opinion with respect to the market value of this popcorn in 1953 and 1954?

A. Yes; I have.

Mr. Tassock: I wonder, if the Court please, if we would be permitted at this time to write these figures down on the blackboard?

The Court: All right, if you want to. It is usually not necessary, but you may.

Mr. Tassock: In the course of the later testimony it may be helpful. [19]

Q. Mr. Alver, would you state, then, what in your opinion was the market value of popcorn of the kind and quality described in Plaintiffs' Exhibit No. 1, the contract involved here, in lots of 600 100-pound bags, or carload lots, in other words, starting in October of 1953 through, we will say, September 1, 1954; that is, from October to September what the market price was.

A. October, \$8.00 per bag f.o.b. Watseka.

(Testimony of Harold M. Alver.)

Q. That is f.o.b. Watseka? A. Yes.

Q. That was the way the contract was written. What does that mean, f.o.b.?

A. That is loaded on a common carrier at Watseka, Illinois.

Q. And the buyer pays the freight from that point?

A. The customer pays the freight. November, \$8.00; December, \$7.00; January, \$6.50; February, \$6.00; March \$6.00; April, \$5.50; May, \$5.50; June, \$5.00; July, 5.00; August, 7.00; and September, \$7.00.

Q. Are those prices right down to the last penny during each month?

A. No; there could be a variation of 25 cents up or down, depending upon the quantity as well as different parts of the country there might be a slight variation.

Q. But that is within a quarter of a dollar one way or the other during the month as the average price? [20] A. Yes.

Q. Is that price that you have given for carload lots?

A. Yes; full carload and full truckload lots.

Q. Is 600 bags of 100 pounds each a carload lot?

A. Yes; that is considered a carload.

Q. Are you personally familiar with the quality of the 1953 crop that you received from the farmers?

A. Yes; I am.

Q. Were the plaintiffs ready, willing and able

(Testimony of Harold M. Alver.)

from October 1, 1953, to September 1, 1954, to deliver to the defendant at Watseka, Illinois, in such installments of 600 100-pound bags as the defendant might request from time to time during such period 3600 100-pound bags of Golden Rocket popcorn, South American Yellow Hybrid variety, warranted to pop 30 to 1 on the official volume tester, at a price of \$9.00 per hundred-pound bag, including the bag, f.o.b. Watseka, Illinois?

A. Yes; we were. In fact, we had far in excess of that amount of corn.

Q. Let me ask you this: If the defendant had ordered corn at any time during that period from October 1, 1953, we will say up until September of 1954, would you or would the plaintiffs have had any expenses in addition to the expenses that you had actually incurred during that period?

A. No; there would be no additional expenses.

Q. Now, did the plaintiff, Premier Popcorn here, or did you [21] during that period from October 1, 1953, to, say, September of 1954, sell any carload lots of popcorn of the kind and quality stated in the contract at a price in excess of the market prices as stated in your testimony prevailing at the time of such sales?

A. No; we did not.

Q. You stated in your answer to a previous question that the 1953 crop amounted to approximately 20,000,000 pounds of shelled popcorn. How much of this corn of the 1953 crop did you have on hand, would you say, in July of 1955? How much did you still have left?

A. About 7,000,000 pounds.



(Testimony of Harold M. Alver.)

Q. You still had 7,000,000 pounds of it. What happened to that '53 crop, if you know?

A. It was sold in bulk to five or six other buyers.

Q. About when did that take place?

A. September of 1955.

Q. What price did you get for that?

A. \$4.50.

Q. \$4.50 per 100 pounds?

A. Per 100 pounds; yes. that was without a bag. It would have been \$4.75 with a bag.

Q. Then if the defendant here had ordered the corn, there would have been 3600 pounds of popcorn that you eventually sold for \$4.75 that you would have sold for \$9.00? A. Yes. [22]

Mr. Tassock: I have no further questions, your Honor.

#### Cross-Examination

By Mr. Reynolds:

Q. Mr. Alver, you stated in your testimony that there was reference to the open market on corn at the time that you were discussing with Mr. Willman the possible reduction from \$9.00 to \$8.00. Did you mean to say that you actually used the words to Mr. Willman "open market corn"? A. Yes.

Q. I believe in your testimony you stated that in the letter of October 23rd, 1953, which is Plaintiffs' Exhibit No. 3, you referred to open market corn. Did you so testify?

A. Yes. Market corn; yes.

(Testimony of Harold M. Alver.)

Mr. Reynolds: I wonder if we could have Exhibit 3 a minute? Will you hand it to Mr. Alver?

Q. Does it say anything actually in that letter about open market corn?

A. Do you want me to read it?

Q. Yes; maybe that would be best.

A. "As to the contract dated May 11, 1953, we will hold this contract in abeyance and ship you popcorn for the time being at a price of \$8.00 a hundredweight, including the bag, f.o.b. our [23] plant."

Q. That is fine. You testified with reference to the conversation in Mr. Willman's office in Portland in November of 1953, when I believe you came out to check on some other car of corn. Who was present during the time that you were discussing the price on this May contract?

A. Mr. Willman and myself.

Q. Do you recall whether Noel Bennett, our salesman, was there?

A. He was in the building. He wasn't in the office that I was sitting in with Mr. Willman.

Q. Would you say that he was not ever there in your presence? A. Yes.

Q. You also testified that during that conversation you talked about insisting that Mr. Willman order out the 3,600 bags on your May contract. Now at that time the May contract was actually for 7,200 bags, wasn't it? A. Yes.

Q. Did you tell him that you expected him to order out the 7,200 bags?

A. No. I told him that we expected him to live

(Testimony of Harold M. Alver.)

up to that contract. However, we would hold up delivery on that contract for the time being if he wished to purchase some \$8.00 market price corn from us, which he had, I assumed, agreed to do. I was asking him for shipping instructions on some popcorn, [24] either \$9.00 contract corn or \$8.00 market price corn.

Q. Now, as to the length of time that you would hold up the May 11th contract, was there any specific time ever set, Mr. Alver?

A. No specific time was set. We had in mind January 1st, holding it up for three months. That had been mentioned. However, no time had been set for the holding up of the \$9.00 contract.

Q. That January 1st time was not mentioned to Mr. Willman, though?

A. In our conversations it had been mentioned, I believe.

Q. Isn't it a fact that you were actually prepared to hold up that contract almost indefinitely?

A. If the occasion had arose, I imagine we would have held it longer than that had Mr. Willman purchased his monthly requirements at the market price.

Q. You mean at the market price or at the \$8.00 price?      A. At the \$8.00 price.

Q. Now, the first notice that you gave to Mr. Willman that you no longer would hold the contract in abeyance was your letter of December 22nd, which is Plaintiffs' Exhibit No. 5. Is that correct?

A. Yes, it is.

(Testimony of Harold M. Alver.)

Q. And to that you attached an invoice for two cars of corn? A. Yes. [25]

Q. Or for three cars. Maybe you better look at that, if you will, Exhibit No. 5.

A. For the three cars, the October, November and December shipments.

Q. At the \$9.00 price? A. Yes.

Q. When you received these purchase orders from Mr. Willman for \$8.00 corn you could have shipped it at \$8.00 if you had so desired; is that correct? A. Yes, we had the corn.

Q. Did you ever discuss with Mr. Willman the possibility of shipping under those purchase orders at \$8.00 and leaving open for further settlement the difference between the \$8.00 and the \$9.00?

A. No.

Q. Now, after the popcorn convention in Chicago, did you talk to your partners about this possible change in price that Mr. Willman asked about?

A. Yes.

Q. And did you, as a partnership, come to any agreement on that question? A. Yes.

Q. Did your letter of October 23rd embody that agreement that you arrived at?

A. Yes. [26]

Mr. Reynolds: I believe that is all the questions I have, your Honor.

(Testimony of Harold M. Alver.)

### Redirect Examination

By Mr. Tassock :

Q. Mr. Alver, just one question here: You were asked if you had ever discussed with Mr. Willman the possibility of shipping the \$8.00 corn and leaving the additional question of \$1.00 open for further negotiations. I would ask the Clerk to hand you the two purchase orders, and I would like you to read those, particularly the language which says, "Ship under no other conditions."

A. To Premier Popcorn Company from Poppers Supply Company of Portland, "Ship one 600-bag car of popcorn from sales contract dating May 11, 1953, to arrive in Portland the last week of January, 1954. This car of corn to have as good a popping volume as the last two cars received from your company. The price of this corn to be \$9.50 f.o.b. Portland as you quoted last November. Ship another 600-bag car to arrive in Portland approximately March 25, 1954, with the same above specifications. If sight draft bill of lading is used, be sure to specify 'inspection allowed.' Do not ship under any other terms." Signed, "Herman Willman."

Q. Let me ask you this question: What is the freight rate between Watseka and Portland? [27]

A. A dollar and a half.

Q. So that \$9.50—

A. \$9.50 delivered Portland was the equivalent



(Testimony of Harold M. Alver.)

of \$8.00 f.o.b. Watseka. The second purchase order, dated February 2nd, to Premier Popcorn Company from Poppers Supply Company: "Because you have not shipped the corn ordered by Purchase Order No. 1856, dated January 5, 1954, we must cancel that order and issue the following revised purchase order, with shipping instructions for all six cars of popcorn, all in accordance with the contract dated May 11, 1953, as amended May 20 and October 23, 1953. This corn is to have as good popping volume as the last two cars received from your company. The price of this corn is to be \$8.00 f.o.b. Watseka, Illinois. If sight draft bill of lading is used, be sure to specify 'inspection allowed.' Do not ship under any other terms.

"Ship one 600-bag car of popcorn on February 6, 1954; ship one 600-bag car of popcorn on March 25, 1954; ship one 600-bag car of popcorn on May 3, 1954; ship one 600-bag car of popcorn on June 20, 1954; ship one 600-bag car of popcorn on July 30, 1954; ship one 600-bag car of popcorn on September 2, 1954.

"Confirm order by return air mail. Poppers Supply Company, Herman Willman."

Q. Those two purchase orders didn't leave any room for [28] discussion, did they? A. No.

Q. You testified that Mr. Willman had told you in a telephone conversation on January 5th—do you remember the exact words that he told you?

A. He said we could keep our God-damned pop-

(Testimony of Harold M. Alver.)

corn and sue him and he would drag it through the courts for three years.

Q. You remember those words exactly, do you?

A. I do.

Q. How do you happen to remember that?

A. Well, we had just finished prior to October delivering Mr. Willman 7,200 bags of corn. He had paid us a price of \$9.00 during the year 1952. At that time the market price was \$12.50, and we delivered to him every pound of that corn. He was buying it at \$3.50 under the market price, and we saved him approximately \$25,000 in the previous year. And now the minute the market dropped—

Mr. Reynolds: Your Honor, just a minute—

The Court: He may continue. He may tell his story.

The Witness: Now that the market dropped a dollar under \$9.00 he refused to take the corn.

Q. (By Mr. Tassock): You were not inclined to discuss, then, letting this \$1.00 await further negotiations? A. No.

Mr. Tassock: That is all.

(Witness excused.) [29]

Mr. Tassock: That is the plaintiffs' case, your Honor.

(Plaintiffs rest.)

HERMAN P. WILLMAN

the Defendant herein, was produced as a witness in his own behalf and, having been first duly sworn, was examined and testified as follows:

Direct Examination

By Mr. Reynolds:

Q. Mr. Willman, you are the defendant in this case; is that correct?      A. That is correct.

Q. What is your business?

A. I operate Poppers Supply Company, which is a wholesale firm dealing in all concession items.

Q. Now, you have just heard Mr. Alver testify with reference to a telephone conversation that you had with him on January 5th of 1954. He said that you told him to keep his "damned corn" or his "God-damned corn." Did you say that to him?

A. I did not.

Q. Did you tell him that you would drag him through the courts for two or three years?

A. I did not. [30]

Q. Will you tell the jury a little bit about how your business operates?

A. Yes. My business operates in this manner: We carry all types of equipment and supplies for the concession people, such as the theaters, the ball parks, and so on and so forth. We carry popcorn, boxes, oils, syrups and every type, practically, of equipment and supplies for the various concession operators.

Q. Where do you get your popcorn?

(Testimony of Herman P. Willman.)

A. Most of the popcorn comes out of the Middle-west.

Q. How long have you known Mr. Alver here?

A. I think I have known Mr. Alver, probably, five or six years now.

Q. How did you come to know him?

A. As a popcorn processor.

Q. Had you purchased corn from him in the past?

A. Yes, I have purchased corn from Mr. Alver.

Q. At the time that you executed this contract of May 11th, 1953, which is Plaintiffs' Exhibit No. 1, did you have any particular conversation with Mr. Alver about the price?

A. Yes. We were talking about price. Mostly about quality.

Q. What did either of you say about quality?

A. He said that their company had a special new seed, which I knew did exist, and he was saying that anyone who would sign a contract with them would get the corn from this special seed [31] which was to pop at 37 or 38 to 1, which is a volume 5 to 6 points higher than any other corn, normal corn.

Mr. Tassock: If the Court please, there is no allegation here that the contract does not state the agreement of the parties with respect to the quality of the corn.

The Court: We will see what the next question is.

(Testimony of Herman P. Willman.)

Q. (By Mr. Reynolds): When did you next talk to Mr. Alver about this contract?

A. Well, I called Mr. Alver several times during the summer period when we would be ordering out a car of corn from a previous contract. Oftentimes we talked about the corn that he was raising that summer. Perhaps the largest conversation took place in Chicago at the popcorn convention on October 12th, 13th and 14th. I believe those were the dates.

Q. During that conversation, was the contract price mentioned by either of you?           A. Yes.

Q. Will you tell the jury just what you said and what Mr. Alver said, if anything.

A. Yes. During the popcorn convention in Chicago I talked to Mr. Alver, I think perhaps every day, and perhaps four or five times each day, and I told Mr. Alver the market was going down considerably and I asked him if he would consider giving us some relief on this contract price. Mr. Alver [32] stated that he would go back and talk to his partners and let me know.

Q. Did you mention any specific figure?

A. At that time there was no specific figure mentioned.

Q. When was the next time you had any communication with Mr. Alver?

A. On October 23rd Mr. Alver called me and he says, "Mr. Willman, I have talked it over with my partners and," he says, "we will"—he asked me if this would be satisfactory to me: He says, "We will



(Testimony of Herman P. Willman.)

reduce the price on the one 800-bag car that we had coming from a previous contract"—that they would reduce the price from \$12.50 f.o.b. Portland to \$10.50 f.o.b. Portland. And he said on the May 11th contract that, for the time being, they would lower the price from \$9.00 to \$8.00 f.o.b. Watseka, with this provision: That if the market price went back up to \$9.00 they would want then to go back to the \$9.00 price. He asked me if that was agreeable and I said it was. I asked him to give me a letter in writing to that effect.

Q. Did you receive such a letter?

A. I did.

Mr. Reynolds: I wonder if the Clerk would hand the witness Exhibit No. 3.

The Court: We will recess now until 1:30. Ladies and Gentlemen, don't discuss the case or permit it to be discussed [33] in your presence until it is finally submitted to you.

(Thereupon, a recess was taken until 1:30 p.m. of the same day, at which time Court reconvened and proceedings herein were resumed as follows.)

H. P. WILLMAN

resumed the stand and was further examined and testified as follows:

Direct Examination  
(Continued)

By Mr. Reynolds:

Q. You have been handed Exhibit No. 3. That is the letter referring to hold the contract in abeyance, I believe, Mr. Willman?

A. That is correct.

Q. You did receive that letter? A. I did.

Q. Now, either in that letter or in prior conversations did you ever talk to Mr. Alver about shipping open market corn?

A. No, that had never been mentioned up to this time.

Q. After receiving that letter when is the next time that you had contact with Mr. Alver?

A. On November 5th Mr. Alver shipped us the last car of corn from the previous contract, and part of that car of corn [34] was defective in certain respects. I called Mr. Alver on November 5th and told him that this car of corn contained other types of corn in it. Mr. Alver didn't believe me, and he said, "Let the corn sit on the track until I can fly out and examine the corn myself." On November 9th Mr. Alver arrived in Portland to examine the car of corn.

Q. During that visit did you have any conversation with him concerning the contract price under this May 11th contract?

(Testimony of Herman P. Willman.)

A. Yes. We talked about the amount of corn that was grown in 1953, and again we talked about changing the contract, and right along this same line the same thing was said once more, that he would change the price on the contract from \$9.00 to \$8.00, but again he specified this one point, that in the event the market price of corn went up he would want to go back to the \$9.00 price. And I told him that was very agreeable.

Q. In that conversation was there any mention of the January 1st date to return to the contract price?      A. None whatsoever.

Q. Was there any mention of when any of the corn under the May 11th contract should be shipped?

A. It was not discussed at that time, because on November 6th we had just unloaded the last car of the previous contract. Mr. Alver and I both knew that it takes 30 to 45 days to get [35] rid of a car of corn, which would put us into the first of January before we would be able to order out any more corn.

Q. Who was present during those conversations?

A. When Mr. Alver was in my office on November 9th Mr. Bennett, my salesman, was with us part of the time. The office girl was very close to the office where we were conversing. However, she says she didn't hear any of the conversations. Mr. Bennett was in the office with us when we were talking about the popcorn yield, the crop and the price.

(Testimony of Herman P. Willman.)

Q. Was he there during the time you were talking about the price on this May 11th contract?

A. He was.

Q. That is the gentleman sitting here on my right?

A. That is correct.

Q. Did you at that time talk to Mr. Alver concerning that Exhibit No. 3 you have in your hand?

A. I don't think we talked about this letter, no.

Q. Have you ever up to this time and including this time ever discussed with him the meaning of the word "abeyance" as used in that letter?

A. That word was never uttered, I don't believe, by either party.

Q. When was the next time you had contact with Mr. Alver [36] concerning this contract?

A. On December 15th I wrote to Mr. Alver that we were canceling the last six cars of corn as per his previous agreement of May 20th.

Q. Then next after that when did you have contact with him?

A. I think the next thing that came along was Mr. Alver's invoices and his letter of January 5th.

Mr. Reynolds: I wonder if the Clerk would hand the witness Exhibit No. 5.

Q. Is that exhibit the one you have just referred to?

A. Yes, that is correct.

Q. That is dated December 22nd, 1953, I believe.

A. That letter was received in Portland on January 5th.

Q. And that letter has attached to it an invoice, I believe.

A. It does.

(Testimony of Herman P. Willman.)

Q. When you received that, what did you do?

A. When I received this invoice—it calls for 1800 bags of Golden Rocket popcorn at \$9.00. Now previous to this invoice every bit of corn shipped from Premier Popcorn Company to Poppers Supply Company had always been freight prepaid. When I looked at this invoice and it said a \$9.00 price I wondered about it, if Mr. Alver was cutting the corn an additional 50 cents a bag. I wondered about it long enough [37] until I called Mr. Alver that same day to see why that \$9.00 price was on those invoices.

Q. Now what was said by both of you in that telephone conversation?

A. I called Mr. Alver and I asked him if he was further reducing the price of the corn 50 cents a bag. Mr. Alver says he was not. He said he was going back to the original contract price. I asked Mr. Alver why he was going back to the \$9.00 price rather than the \$8.00 price, and all Mr. Alver would say was that he was simply going back to the \$9.00 price.

Q. Was there anything said in that conversation concerning shipping instructions under the contract?

A. Mr. Alver did ask us to explain our position to him, and we did put it in writing by sending through a purchase order for two cars of corn at that very same date.

Q. Did you have any further contacts with Mr. Alver concerning this contract?

A. I think the next letter we received from Mr. Alver was that his company was in financial difficul-



(Testimony of Herman P. Willman.)

ties and was operating under the jurisdiction of the Federal Court.

Mr. Reynolds: I wonder if you would hand the witness Exhibit No. 13.

Q. Is that the letter to which you just referred?

A. That is. [38]

Q. It is dated December 15th or December 16th, 1953?

A. Evidently this came in previous to the January 5th telephone call.

Mr. Reynolds: I think there are about three exhibits in Mrs. Mundorff's possession that have not been introduced. I wonder if I could have those.

I am offering in evidence, your Honor, Exhibit No. 12, which is a telegram from Mr. Willman to Premier Popcorn, the plaintiff. Is that all right?

Mr. Tassock: Yes.

The Court: Admitted.

(Photostatic copy of telegram above referred to, dated February 11, 1954, was received in evidence as Defendant's Exhibit 12.)

Mr. Reynolds: Would you be good enough to hand that to the witness?

Q. That is a telegram from you to Mr. Alver's firm, is it not? A. That is correct.

Q. What is the nature of that? It is short. You might just read it.

A. "We are completely out of corn and must know today by return wire if you are shipping corn

(Testimony of Herman P. Willman.)

from our Purchase Order 1867 dated February 2, 1954. Poppers Supply Company.”

Q. Did you receive any reply to that wire? [39]

A. None whatsoever.

Q. Did you have any further conversations with Mr. Alver concerning this contract?

A. There was a previous telephone call to Alver's firm shortly after we sent the first purchase order. I called him to find out if they were shipping corn, and I talked to Mrs. Alver. Mr. Alver was out. And she said she would have Mr. Alver contact me and let me know when they were shipping the corn. And I never heard anything from that purchase order either. This wire is in regard to the second purchase order.

Q. The second purchase order being for six cars?

A. That is right.

Q. Now were you at all times willing and able to order out and accept corn under this contract at \$8.00? A. Yes.

Q. But none was ever shipped; is that correct?

A. None was ever shipped.

Q. Exhibit No. 11 covers six cars of corn, does it not? A. That is correct.

Q. Is that the purchase order you were just referring to when you were talking about the telegram? A. That is correct.

Mr. Reynolds: If it please the Court, we would also like to offer in evidence Exhibit No. 10. This is a letter [40] from Mr. Stirling to Mr. Clark. I will offer this in evidence.

(Testimony of Herman P. Willman.)

Mr. Tassock: No objection.

The Court: Admitted.

(Photostatic copy of letter referred to, dated February 2, 1954, was received in evidence as Defendant's Exhibit 10.)

Mr. Reynolds: I think that is all we have now. We may have some redirect, your Honor.

### Cross-Examination

By Mr. Tassock:

Q. Mr. Willman, you have been referring to two purchase orders that were sent ordering corn out at \$8.00. A. Yes.

Q. I want to ask you did you know at that time of sending both of those purchase orders that the plaintiff here was insisting on a \$9.00 price?

A. Well, yes.

Q. That question can be answered Yes or No.

A. Yes.

Q. If I understand your testimony correctly, you indicated that there was an agreement that the contract price was to be reduced from \$9.00 to \$8.00. Now I want to ask you this question: Did you give the plaintiff any cash or monetary consideration for that reduction? That can be answered Yes [41] or No. A. No.

Q. Did you promise to do anything for that reduction? A. No.

Q. Did you give the plaintiff anything for that reduction? A. No.

Mr. Tassock: No further questions, your Honor.

(Testimony of Herman P. Willman.)

Redirect Examination

By Mr. Reynolds:

Q. When you answered that you didn't promise to do anything, was there any agreement that you were going to accept any corn at \$8.00?

A. We would take the six cars of corn at \$8.00.

Q. At that time how long had you been buying corn from Mr. Alver?      A. Perhaps two years.

Q. Did Mr. Alver ask you to give anything other than agreeing to take the six cars of corn when this \$8.00 price was discussed?      A. He did not.

Q. Did he say anything about the price going back up, or in the event the market price went up?

A. In the event the market price went back up we were going to go back to the \$9.00 price. [42]

Q. And did he agree to ship you corn under that contract at \$8.00?      A. He did.

Mr. Reynolds: Mr. Tassock, will you require me to qualify him as an expert on market price?

Mr. Tassock: No, that is all right.

Q. (By Mr. Reynolds:) Do you know, Mr. Willman, the market price of popcorn of the type, variety and quantity covered by this contract at Watseka, Illinois, during the month of October, 1953, and through September of 1954?

A. I have made a very careful study of those prices, and also contacted perhaps the largest processor in the entire industry and asked them for their prices for those months.

(Testimony of Herman P. Willman.)

Q. Do you know presently what those prices were?       A. Yes.

Q. I wonder if I might list them. October of 1953?

A. October it still was \$9.00. November was \$8.00; December was \$7.00; January was \$7.25; February was \$6.75; March was \$6.00. Through the summer it stayed practically at \$6.00 until August, when the market started to firm up.

Q. That would be April, \$6.00; May, \$6.00; June, \$6.00; and July, \$6.00. Now would you say in August it was still \$6.00?

A. In August the market started to rise. It went up to about \$6.50 to \$6.75 in August. [43]

Q. Do you have the figure for September?

A. September would run \$7.00.

Mr. Reynolds: I would like your permission, Mr. Tassock, to write "Alver" over this column. That is yours.

Mr. Tassock: All right.

Mr. Reynolds: And "Willman" over the other one.

(Mr. Reynolds identified the two columns on the blackboard as indicated.)

Q. (By Mr. Reynolds): Mr. Willman, we have been talking about \$8.00 and \$9.00. The contract, Exhibit No. 1, I think actually says \$8.75. What is the reason for that difference?

A. The reason is that Mr. Alver has given his customers the opportunity of furnishing their own



(Testimony of Herman P. Willman.)

bag to put the corn in. In the event that Mr. Alver furnishes the bag, then he charges 25 cents for the bag, which would bring the price up to \$9.00.

Q. That price would only obtain, then, on a bag basis; it would not obtain on a bulk basis?

A. No, that price would not obtain on a bulk basis.

Q. Did Mr. Alver ever approach you with the idea of shipping corn at \$8.00, leaving open the question of the difference between \$8.00 and \$9.00 for future negotiations? A. No.

Mr. Reynolds: That is all, your Honor. [44]

#### Recross-Examination

By Mr. Tassock:

Q. In the course of your deposition, Mr. Willman, you testified—this question was put to you: “What was the market price about this time, November 11th?” And your answer was: “About \$8.50 f.o.b. Portland.” Is there any particular reason why there is that discrepancy? You have \$8.00 listed there.

A. Yes, sir. I have seen various prices from various companies. The prices I have there come from the Central Popcorn Company, which is the largest in the industry. They took every one of their entire sales for that entire period of time and averaged those out, and that is their prices. Now I have seen other sales in small amounts and in some large amounts lower and higher than those figures.

(Testimony of Herman P. Willman.)

Q. But your testimony is based upon the information which they gave you?

A. That is correct.

Mr. Tassock: I move at this time, your Honor, that his testimony be stricken as being incompetent.

The Court: Motion denied.

Q. (By Mr. Tassock): As I understand your testimony, Mr. Willman, those figures are mathematical averages. In other words, there would be sales in the particular time which would be lower than those figures that you have mentioned and there [45] would be others which would be somewhat higher than those figures?

A. That is right.

Q. This is a mathematical average?

A. It is a mathematical average over all of their entire sales for each month.

Q. Those sales, of course, would include their contract sales, would they not?

A. I wouldn't know. I presume they would. It is their entire sales.

Q. So if they had also future contracts which they had made in the spring of the year before the planting at a higher price, for example \$9.00, those figures would be included in those calculations, wouldn't they?

A. For your information, the Central Popcorn Company reduced every contract they had in price.

Q. That didn't answer my question. I don't know that you are competent to give the testimony you have just given. You don't know what they did. I

(Testimony of Herman P. Willman.)

am asking you this: Do those figures include the sales that this company that you are relying on made on their future contracts?

A. It would include all of their sales.

Q. All of their sales?

A. All of their entire sales.

Q. And these figures include the bags, do they not? [46]

A. They would.

Mr. Tassock: 25 cents on the bags. No further questions, your Honor.

Mr. Reynolds: That is all.

(Witness excused.) [47]

#### NOEL BENNETT

was produced as a witness in behalf of the Defendant and, having been first duly sworn, was examined and testified as follows:

#### Direct Examination

By Mr. Reynolds:

Q. What is your occupation, Mr. Bennett?

A. Salesman for Poppers Supply Company.

Q. How long have you been so employed?

A. A little over six years.

Q. You have heard the testimony concerning a meeting between Mr. Alver and Mr. Willman in November of 1953. Do you recall such a meeting?

A. Yes, I do.

Q. Where was it?

(Testimony of Noel Bennett.)

A. In Mr. Willman's plant office at 206 North-east 7th at that time.

Q. Were you with Mr. Alver all of the time that he was here in Portland that time?

A. I don't know what time Mr. Alver left. I was with him the better part of an hour and a half that day.

Q. Did you hear any conversation between Mr. Alver and Mr. Willman concerning the price of corn under the contract dated May 11th, 1953?

A. Yes, I did.

Q. Where did that conversation take place? [48]

A. In Mr. Willman's private office.

Q. Will you tell the jury what Mr. Alver and what Mr. Willman said.

A. Well, in the beginning the talk was in regard to the settlement on this defective car of corn, and after that was settled, why, then they began talking about the new contract. And during that conversation Mr. Alver told Mr. Willman that he was cutting his contract price a dollar a bag and that should give us some relief.

Q. Did Mr. Willman make any statement then?

A. I don't remember the exact words. No, I don't.

Q. Did Mr. Willman say anything about whether or not he would take corn at \$8.00?

A. Well, yes, he did.

Q. Did you hear mentioned at that time the word "abeyance"?

A. No, sir; I didn't.

(Testimony of Noel Bennett.)

Q. Was there any mention of a different price to obtain in the future on the contract?

A. I don't remember that. I couldn't say for sure.

Q. Or was the date January 1st mentioned at that time?           A. No, I don't remember that.

Mr. Reynolds: That is all. [49]

### Cross-Examination

By Mr. Tassock:

Q. Do you remember, Mr. Bennett, anything that was said other than that Mr. Alver agreed to reduce the price \$1.00? Do you remember anything else definitely?

A. Yes, I remember the settlement on the car of defective corn. That is, I know that they talked about that first.

Q. You were present when that was done?

A. Yes.

Q. How long have you been employed by Mr. Willman here?           A. Six years.

Q. Is your salary adequate?

A. Very fine.

Q. Satisfactory. How old a man are you, Mr. Bennett?           A. 39.

Q. How many dependents do you have?

A. Six.

Q. Did you have occasion to discuss this matter with Mr. Willman after Mr. Alver left?

A. Yes, you bet.



(Testimony of Noel Bennett.)

Q. What was said, as you recall?

A. We were very happy that we were going to get our corn price reduced so that we could meet competition.

Q. Mr. Willman was very happy at that time?

A. We both were. [50]

Q. Did he express this to you on several occasions afterward?

A. Well, naturally, the time that I am in the office—most of the time is spent talking about corn sales and equipment sales and conditions in the field.

Q. You say he was definitely delighted at that point because the price had been reduced?

A. Naturally.

Q. Did you leave there before their conversation had concluded?

A. I believe I did. I think I left before Mr. Alver did.

Q. He stayed there for some time?

A. I don't know how long he stayed there after I left.

Mr. Tassock: No further questions.

Mr. Reynolds: That is all.

(Witness excused.)

Mr. Reynolds: That is the defendant's case, your Honor.

Mr. Tassock: If the Court please, there is a deposition in the file, and parts of it I would like to introduce into evidence for the purpose of im-

peachment of Mr. Bennett. May I read from the copy? I only want to put in portions of it, your Honor.

Mr. Reynolds: If the Court please, I don't believe [51] there are any depositions in this case.

Mr. Tassock: The depositions in the previous case, Civil No. 7440, are admissible in this case under Rule 26-D of the Federal Rules.

The Court: I would think so.

Mr. Tassock: Sir?

The Court: I would think so.

Mr. Tassock: If the Court please, may I proceed by just reading the questions and answers?

The Court: If you want to do it that way. Any way you want to do it.

Mr. Tassock: I am reading from the deposition taken of Mr. Noel S. Bennett, taken on September 3rd, 1954, which was used in connection with another trial of this case.

The Court: Is that this gentleman?

Mr. Tassock: Yes.

The Court: Don't you have to call his attention to that while he is on the stand if you claim he has made inconsistent statements here?

Mr. Tassock: I don't know, your Honor. No, I don't think so.

The Court: Don't you have to give him a chance to admit or deny it or explain it? I think you do.

Mr. Tassock: All right.

The Court: Come back here. [52]

NOEL BENNETT

a witness produced in behalf of the Defendant, resumed the stand and was further examined and testified as follows:

Further Cross-Examination

By Mr. Tassock:

Mr. Reynolds: Pardon me. May I inquire now the status of the witness? Is he the plaintiff's witness?

The Court: He is your witness and the cross-examination is continuing. He is about to ask him some impeaching question.

Q. (By Mr. Tassock): As I recall your direct testimony, Mr. Bennett, you testified that you knew about the settlement that was made with respect to the car of corn that Mr. Alver came out to inspect, and that that was discussed at the time of your meeting there on that day with the three of you.

A. That was part of the discussion, yes.

Q. Now, in the course of your deposition——

The Court: Give the time and place.

Q. ——which was given in Portland, Oregon, on September 3rd, 1954, I asked you: "What was decided with respect to that corn that was supposed to be mixed; do you recall?" And you testified: "I am not positive what settlement Mr. Willman came to on that with him." I asked you: "Have you got any ideas?" You said: "Not for sure."

Your testimony then was that you didn't know

(Testimony of Noel Bennett.)

what [53] the settlement was, and I understood you to say a moment ago that you did; that you heard what it was. Now were you present and learned what the settlement was, or weren't you?

A. Yes, I was. I was present.

Q. Do you now recall what the settlement was?

A. I think it was 50 cents a bag on the corn.

Q. But at this time you didn't know, in 1954?

A. It probably came to my mind since that deposition.

Q. Then I asked you this question: "The only thing that you remember for sure was that Mr. Alver said he was going to cut the price of corn \$1.00," and your answer was, "That is right." The next question: "That is all you remember about the conversation?" And your answer: "Well, I will tell you why I remember that definitely, because we talked about it after Mr. Alver left and we were very happy."

Now there again your testimony was that you remembered nothing else other than the conversation relating to the reduction of the contract.

A. Well, there was lots of talk that morning, crop yield, prices——

Q. All of which you remember now but didn't remember then?

A. It is possible.

Mr. Tassock: No further questions, your Honor.

Mr. Reynolds: That is all.

(Witness excused.) [54]

The Court: They have rested.

Mr. Tassock: I would like to call Mr. Alver for one question.

HAROLD M. ALVER

the Plaintiff herein, was recalled as a witness, in Rebuttal, and was further examined and testified as follows:

Direct Examination

By Mr. Tassock:

Q. Mr. Alver, in connection with Plaintiffs' Exhibit 3, the letter of October 23rd, which reads as follows:

“Confirming our telephone conversation today, we will ship next week the balance of your contract dated December 31, 1952, 800 bags, at a price of \$10.50 f.o.b. Portland instead of the price of \$12.50 as stated in the contract.”

Now in that instance you made a definite reduction of this 1952 contract. Could you explain what would be the difference between the '52 situation and the contract of May 11th with which we are dealing in 1953.

A. Mr. Willman refused to take that car of corn at \$12.50. He wanted a reduction. And we were then in the new crop of 1953, and that corn had not cost us as much or didn't cost us [55] as much as the corn that we had previously applied or held for that sale. So, since he refused to take it at \$12.50, we reduced it to \$10.50 delivered Portland. Then after he got the car of corn he complained that there was some white corn—



(Testimony of Harold M. Alver.)

Q. Answer the question. I just wanted to know—if I understand you, your 1952 contract was based upon corn that you had purchased in 1952 from the farmers? A. Yes?

Q. But by the time this delivery rolled around you had begun to receive your 1953 corn which had been purchased at a lower price from the farmers?

A. Yes.

Mr. Tassock: No further questions, your Honor.

### Cross-Examination

By Mr. Reynolds:

Q. Mr. Alver, did you say that Mr. Willman refused to take that car of corn you were just talking about? A. At \$12.50, yes.

Q. How did he make known to you his refusal?

A. In a telephone conversation.

Q. Do you recall when that was?

A. October 23rd. It was at the time I wrote that letter reducing the price to him. [56]

Q. Do I understand that you had a lot of extra corn on hand at that time, and that is why you were willing to make this deal on this particular car?

A. The corn I had on hand had cost me less than the previous corn had, so I could make that reduction to him.

Q. You had corn on hand and no place to put it?

A. Yes.

Q. Is that correct?

A. That is right. He had refused to take it at

(Testimony of Harold M. Alver.)

\$12.50, so I did the next best thing and sold it to him at \$10.50.

Q. Now with reference to the 1953 crop, you had a big surplus of that, too, did you not?

A. Yes.

Mr. Reynolds: That is all.

### Redirect Examination

By Mr. Tassock:

Q. That is what you are talking about, is the 1953 crop, isn't it, Mr. Alver? A. Yes.

Q. That you had on hand which had been purchased on '53 prices? A. That is right.

Mr. Tassock: Thank you.

(Witness excused.) [57]

Mr. Tassock: That is all, your Honor.

Mr. Reynolds: We have nothing further, your Honor.

(Whereupon, the jury was excused until 9:30 a.m., Wednesday, December 5, 1956, and after the jury had retired from the courtroom the following proceedings occurred out of the presence and hearing of the jury.)

Mr. Tassock: Just for the record I will make a motion which is similar to the instructions that we requested.

I move the Court to instruct the jury that the defendant has not established a defense that the contract was modified by subsequent agreement as

to price on the ground that such an agreement would be in violation of the statute of frauds and that there was no considerations supporting any such agreement and, therefore, as a matter of law the defendant has not established that defense.

The Court: That would amount to a directed verdict for the plaintiff.

Mr. Tassock: Except on the question of damages, yes.

(Further discussion between Court and counsel.) [58]

December 5, 1956, at 9:30 o'Clock A.M.

(Court reconvened, pursuant to adjournment, and proceedings herein were resumed as follows:)

The Court: One of our jurors has become ill, so I will have to ask you what I am sure you will be willing to agree to; that is, a stipulation that we may proceed with eleven jurors.

Mr. Tassock: The plaintiff will so stipulate, your Honor.

The Court: Is that satisfactory to you gentlemen?

Mr. Reynolds: May it please the Court, there is one matter that I would like to submit, that I suppose should be presented in the absence of the jury.

The Court: Are you willing to go ahead with the eleven jurors?

Mr. Reynolds: On that point we would like to

have some indication of the Court's instructions that you intend to give.

The Court: I am not going to have you impose conditions. You may be sure I will find a way to go ahead with 11 jurors whether you stipulate or not.

Mr. Reynolds: No, we will go ahead with 11 jurors. That is all right, but we have this other motion.

The Court: Take the jury over to the other room. [59]

(Whereupon, the jury was excused from the courtroom and the following occurred out of the presence and hearing of the jury.)

Mr. Reynolds: That this time, your Honor, the defendant moves for a dismissal of this case on the basis that the contract itself provides certain remedies available to the seller in event of a breach. Those remedies are set forth in the contract.

It is this paragraph: "Buyer shall furnish seller complete shipping instructions at least ten days before the stated shipping time for each installment. If buyer fails to give seller shipping instructions as required herein then at the expiration of the stated shipping time seller may at seller's option and without notice (a) hold the goods and invoice the buyer for the same or (b) extend the time of shipment or (c) be excused from delivering the balance of the goods or continuing the performance of the contract."

Our position is that they are limited to the rights

granted them under the contract, and in this case they do not proceed on any of those bases.

Mr. Tassock: If the Court please, I don't believe the paragraph referred to is intended to impose an exclusive remedy. For one thing, the language is that the seller "may." It doesn't say he must exercise one of these options. It says [60] he may exercise any of these options. Our position is it just is not an exclusive remedy, nor could not be.

The Court: Didn't he do "(a)"? Didn't he hold the goods and invoice them?

Mr. Tassock: He did that, yes, for a period, your Honor.

The Court: Didn't he do it at the end?

Mr. Tassock: No, because, as he testified, he couldn't. But he always had enough goods to perform.

The Court: Didn't he at the end of what you call the anticipatory breach period invoice the whole works?

Mr. Tassock: No, not the whole works. But he did up to that point have the goods, and he had the goods all the way through to ship, as a matter of fact, and he did invoice all but the last month. But the evidence here would only show invoices for the first three months. There is no additional evidence as to invoicing.

The Court: This case has had a hectic career. I don't imagine what I am going to say is going to be satisfactory. I know it isn't all around. It isn't the kind of case that I enjoy, because the result,



it seems to me, that is impelled by the record is really not equitable. But the law of sales in the commercial world has never really been equitable.

After reflection overnight, taking these papers home with me and reading them both last night and this morning, [61] I don't see anything much to submit to this jury. I can't follow you gentlemen on your claim that there is a rescission, a question of rescission to be submitted to the jury. That is not your testimony. It may be your theory, but it is not your testimony. Your testimony is that the contract was modified, not rescinded. Your client's two orders there at the end, when he was taking his position—and these people, no doubt under a lawyer's advice at the time, were squaring off to take the position—the last two orders are definitely related to the contract, and they purport to be under the contract of May, 1953. So very clearly it seems to me that what you were saying at that time was that you recognized that the contract was still in existence but it had been modified as to price and you were ordering under the contract but at the lower price.

That is where you get into legal difficulties, it seems to me, because you have to rely upon an oral modification of the contract except as you claim something for that letter with the word "abeyance" in it. That is the only writing that you can claim supports your modification theory. I just don't read that letter the way you claim for it.

So in my view of the case the plaintiff is entitled to a directed verdict, with only one question for the

jury and that is the amount of damages, to whatever extent you differ there. [62]

What is the month that you compute your damages on? February?

Mr. Tassock: I took February or January. I think that would be a question for the jury as to what month, your Honor.

The Court: You have two different prices there in both those months. If you want to argue that question to the jury, I will come back and we can do that. Or it may be that you can agree on a figure between you without waiving your rights. I will come back again in fifteen minutes.

(Whereupon, a short recess was taken, and thereafter the matter was argued to the jury by counsel for the respective parties, and the Court then instructed the jury as follows:)

The Court: Ladies and Gentlemen, the plaintiffs' theory about the damage here is that in the month of January the parties came to the end of this transaction in the sense that at that time—that is one possibility, according to the plaintiffs' way of looking at it—the buyer, the man down here at the end of the table, made it definitely plain that he was not going to go ahead with the deal, so that the damages should be calculated as of that time and the damages would be the difference between the contract price which was \$9.00 per 100 pounds and what the then market price was. The parties differ as to what the market price was. The plaintiff says [63] it was then \$6.50; that it had fallen to

\$6.50 per hundred pounds, whereas, as you see over there, the defendant says it had not fallen that much at that time; that it had only fallen to \$7.25. So if that is the method in which the damages should be figured, the damages would come out differently on account of the difference between the parties as to what the then market was.

Those are the first two figures that I suggest you write down. If you take the \$6.50 market figure, which is the plaintiff's idea, as of that month the damages would be \$9,000, if that is the method to use, whereas if you take the defendant's idea of the market, which is a good deal higher, or \$7.25, the damages would be less. They would be \$6,300.

That is one of the things you may have to resolve in the case. Now, then, if February is the month to take, if that is the month when in fact the parties came to the end of their transaction, by a definite rejection by the buyer of the contract, you have two figures again to deal with because of the difference between the parties as to what the market price then was. As you see on the board, the plaintiffs' idea was that the market had fallen to \$6.00, or \$3.00 less than the contract price. And since the amount in dispute was 3,600 bags, that is one thing we can figure out. Three times 3,600 bags would be \$10,800. That would be the damages [64] if that was the month you took and if that was the market price you took.

The defendant again thinks that the market was higher in that month than the plaintiff does. His

idea was it was \$6.75, as you see. So that is going to make the damages less in that month if that is the month you take, and that figure comes out, so the gentlemen have told me, to \$8,100 rather than \$10,800.

If you accept the line of reasoning that the attorney for the defendant has presented to you, as he has shown you down there at the foot of the board, the damages are \$6,000, and we get still another figure. In fact, he says they should be reduced by the number of bags involved at the price per bag, coming to \$900.00, which drops it to \$5,100.

So you have six possible choices. And the gentleman for the plaintiff who was just speaking took a different view about the bags, so that would make a \$7.00 figure.

I don't know whether I am making this very plain to you. It is pretty mixed up, but that is the way these commercial transactions get sometimes.

In the few brief remarks I am going to make I am going to start with the line of reasoning that Mr. Stirling, representing the defendant, presented to you: That the damages should be figured on each month, beginning back in October when [65] the first delivery was to be taken. His theory comes out pretty plainly when you look at those two figures up there. He says that there was no damage in that month because, according to his figure over there, the market was still the \$9.00 contract price. And he says that that was the month that this man had agreed to take the corn, and he didn't take it, so



the damages should be computed as of that time for that monthly quota, and so on clear through.

I am not going to say that you have to reject that theory altogether, but I am just going to make this comment, which I feel privileged to do. I think that disregards what the parties were doing. You will find a letter in here written in October where the seller is telling the buyer that he will hold the contract in abeyance. There are some differences here about what "abeyance" means. That just shows you better use a simple word when you can and sometimes you come out better. But we have got that word to deal with, and my idea is that that meant an extension. That is what he was saying: "I am not going to ask you to take deliveries because the market has gotten soft, and we will put off to some indefinite time in the future further discussion about this contract." I read "abeyance" to mean an extension of time. So I don't see how you can say that the damages shall be figured in October when the quota for that month had been extended to a future indefinite time. It seems to me that [66] the correct theory in the case is either in January or February, when the parties squared off to have a row over this and got their affairs in the hands of their lawyers, as you will see from the correspondence. That is the time to take. And you will see, as has been argued to you, that the buyer was taking the position in January which indicated that he claimed the contract had been amended and he was not going to observe it, and then you will find the same thing in February. It seems to me your



choice is between those months. And that then puts you back to a choice between the differing figures that result from the different sides as to what the market was in those months.

Now you will have one form of verdict: "We, the jury in the above-entitled matter, find our verdict for the plaintiffs in the sum of blank dollars."

You will elect a foreman on retiring and you will fill in the amount there in the blank space. Your verdict must be unanimous, as in all cases in this court.

The plaintiffs as to questions of fact that are involved have the burden of proof, as in all litigation. They must satisfy you by a preponderance of the evidence, which means the greater weight of the evidence, as to what the damages were in this case which, the way the case has turned, is the sole issue that is submitted to you for consideration. [67]

You will take the exhibits with you and give them the weight you feel they are entitled to in the jury room. You haven't had a chance to read them, and I have put them all here together in chronological order.

I am going to suggest to Mr. Pierce that he bring you back in here so that you may deliberate here. You can lock up the courtroom, and you can have the blackboard here, which will be necessary for your use.

One of the big things in this case, as often develops, is the difference of opinion which has been expressed here as to what was said and done. In other words, the question of credibility is in-

volved. You have to make up your minds as to where the truth lies in this case as between the conflicting claims as to the matters that bear on the issue. You are the exclusive judges of the credibility of the witnesses and of the weight and value of their testimony.

You may swear Mr. Pierce.

(The Bailiff was sworn and the jury retired from the courtroom, after which the following occurred:)

The Court: Gentlemen, state your exceptions, the jury having retired. First the plaintiff.

Mr. Tassock: The plaintiff has no exceptions, your Honor. [68]

The Court: The defendant?

Mr. Reynolds: The defendant objects to the direction that the jury find a verdict for the plaintiffs, and then objects to the failure of the Court to give the instructions submitted.

Further, we except to the Court instructing on any theory of damages other than the \$6,000 or the \$5,100 figure based on the computation using the months of October, November, December, January, February and March for the reason that the Court has ruled that the contract was neither modified nor rescinded by the negotiations nor the letter of October 23rd, and it seems to us, therefore, that the effect of that ruling must be to give no effect to those negotiations or letter, which would put us back to the original position of the parties, so that the maximum damages must be arrived at by using

the figures starting with October, either the figures used by the plaintiffs or by the defendant.

The Court: The exceptions have been considered and respectively overruled.

(Whereupon, proceedings in the above-entitled cause on said day were concluded.)

[Endorsed]: Filed December 26, 1956. [69]

---

### CERTIFICATE OF CLERK

United States of America,  
District of Oregon—ss.

I, R. DeMott, Clerk of the United States District Court for the District of Oregon, do hereby certify that the foregoing documents consisting of Complaint; Answer; Pretrial order, Stipulation re exhibits (Not filed); Plaintiffs' requested instructions (Not filed); Defendant's requested instructions (Not filed); Judgment; Cost bill with notice attached; Motion for order disallowing certain cost bill items; Order sustaining defendant's objections to plaintiffs' cost bill; Notice of appeal; Undertaking on appeal, supersedeas; Designation of contents of record on appeal; Order to transmit exhibits to Court of Appeals; Supplementary designation of contents of record on appeal; and Transcript of docket entries, constitute the record on appeal from a judgment of said Court in a cause therein numbered Civil 8,500, in which H. P. Willman, doing business as Poppers Supply Co., is the defendant and the

appellant and Harold M. Alver, et al., doing business as Premier Popcorn Company are the plaintiffs and appellees; that the said record has been prepared by me in accordance with the designations of contents of record on appeal filed by the appellant and appellees, and in accordance with the rules of this court.

I further certify that there is enclosed herewith exhibits numbered from 1 to 13, inclusive, and the reporter's transcript of proceedings filed in this office in this cause.

I further certify that the cost of filing the notice of appeal, \$5.00 has been paid by the appellant.

In Testimony Whereof I have hereunto set my hand and affixed the seal of said court in Portland, in said District, this 30th day of January, 1957.

[Seal]

R. DeMOTT,  
Clerk.

By /s/ THORA LUND,  
Deputy.

to purchase, and the fact that the contract was held in abeyance for a period of time.

## IV.

The Court erred in directing the jury to base damages upon either the January or February, 1954, market price, thereby precluding the jury from considering the market price during October, November and December, 1953.

## V.

The Court below erred in failing to give the Defendant's four (4) requested instructions.

## VI.

The Court below erred in admitting testimony, from the plaintiff, over defendant's objection, as to what had transpired between the parties with respect to a prior contract (Tr. p. 29), for the reason that such evidence was incompetent, immaterial and irrelevant and highly prejudicial to the defendant.

## VII.

The Court below erred in denying defendant's motion for dismissal, which motion was based on the fact that the contract provided certain remedies available to the plaintiff seller, none of which remedies were pursued by the plaintiff in bringing this suit.

/s/ J. P. STIRLING,

Of Attorneys for Appellant.

Service of Copy acknowledged.

[Endorsed]: Filed February 8, 1957.



United States  
**COURT OF APPEALS**  
for the Ninth Circuit

---

H. P. WILLMAN, Doing Business as POPPERS  
SUPPLY CO.,

*Appellant,*

vs.

HAROLD M. ALVER, OSCAR J. ALVER,  
RAYMOND N. ALVER, LUCILE M. AL-  
VER, JEANNETTE B. ALVER and MIL-  
DRED M. ALVER, a Co-partnership Doing  
Business as Premier Popcorn Company,

*Appellees.*

---

**APPELLANT'S BRIEF**

---

*Appeal from Final Judgment of the United States  
District Court for the District of Oregon.*

HON. CLAUDE MCCOLLOCH, Judge.

---

JOHN F. REYNOLDS,  
Equitable Building,  
Portland 4, Oregon,

J. P. STIRLING,  
3128 N. E. Broadway,  
Portland 12, Oregon,

*Attorneys for Appellant.*

FILED

APR 19 1957

PAUL P. O'BRIEN, CLERK

## INDEX

	Page
Jurisdiction .....	1
Statement of the Case .....	2
Statement of Appellant's Specification of Errors.....	5
Summary of Argument.....	16
Argument .....	18
Point I—Directed Verdict in Error.....	18
Point II—No Mitigation of Damages Instructed....	32
Point III—Improper Damage Findings.....	35
Point IV—Prejudicial Testimony.....	39
Point V—Motion for Dismissal.....	40
Conclusion .....	43

## INDEX OF CASES

	Page
Aetna Casualty Co. v. Yeatts, 122 F. 2d 350 .....	20
Arkansas & T. Grain Co. v. Young, 96 S.W. 142 (Ark.) .....	34
Borden & Co. v. Vinegar Bend Lumber Co., 2 Ala. App. 354, 56 So. 775, 7 Ala. App. 336 .....	34
California Sugar & White Pine Co. v. Whitmer Jack- son & Co., 263 P. 504 (N.M.).....	37
Christian Mills v. Berthold Stern Flour Co., 248 Ill. App. 1 .....	42
Clayton Oil & Refining Co. v. Langford, 293 S.W. 559 (Tex.) .....	32
Cuneo Press v. Claybourn Corp., 90 F. 2d 233 .....	26
Dickerson v. Colgrove, 100 U.S. 578, 25 L. Ed. 618....	30
Ellis Gray Milling Co. v. Sheppard, 215 S.W. 2d 57 (Mo.) .....	32
Empire Box Corp. v. Jefferson Island Salt Mining Co., 36 A. 2d 40 (Del.).....	26
J. C. Engelman v. Sanders Nursery, 140 S.W. 2d 500 (Tex.) .....	35
Engraw v. Schenley Distilleries, 181 F. 2d 876.....	38
Fischer v. Means, 198 P. 2d 389 (Cal.).....	27
Franklin Sugar Refining Co. v. Lykens Mercantile Co., 117 A. 780 (Pa.).....	39
Fulton v. Henrico Lumber Co., 148 S.E. 576 (Va.)....	26
Gentile Bros. Co. v. Rose, 7 F. 2d 879, 6 Circ.....	37
E. T. Gray & Sons v. Satuloff Bros., 105 So. 666 (Ala.) .....	31, 34
Gresham Transfer Inc. v. Oltman, 187 Or. 318, 320, 210 P. 2d 927.....	20
Hastings-Stout Co. v. Bennett, 130 S.E. 334 (S.C.)....	33

## INDEX OF CASES (Cont.)

	Page
Keeter v. Griffith, 241 P. 2d 213 (Wash.).....	26
Krauter v. Simonin, 274 F. 791.....	26
La Grange Grocery Co. v. Lamborn, 283 Fed. 869.....	39
John H. Maclin Peanut Co. v. Pretlow, 11 S.E. 2d 607 (Va.) .....	26
Marx v. Leichner, 121 So. 685 (La.).....	31
National Molasses Co. v. Herring, 221 F. 2d 256.....	18
Newton v. Bayless Fruit Co., 155 Ky. 440, 159 S.W. 968.....	37
Penney v. Burns, 146 So. 611 (Ala.).....	31
Permutit Co. v. Massasoit Mfg. Co., 61 F. 2d 529.....	42
Scruggs v. Riddle, 171 Ala. 350, 54 So. 641.....	37
Simons v. Ypsilanti Paper Co., 77 Mich. 185, 43 N.W. 864.....	37
Smith & Co. v. Russek, 212 F. 2d 338 (5th Circ.).....	37
Standard Rice Co. v. Sims, 119 S.W. 2d 1035 (Ark.)..	26
Utica City National Bank v. Gunn, 118 N.E. 607 (N.Y.) .....	27
Western Auto v. Sullivan, 210 F. 2d 36.....	19
H. R. Wyllie China Co. v. Vinton, 192 P. 400, 97 Or. 350, 363 .....	26

## STATUTES

	Page
28 U.S.C.A. Sec. 1291.....	2
28 U.S.C.A. Sec. 1332.....	1
Federal Rules Civil Procedure, Rule 73, 28 U.S.C.A.....	2
Oregon Revised Statutes 75.040, Statute of Frauds.....	28
Oregon Revised Statutes 75.640, Action for Damage for Non-acceptance of Goods .....	32, 37
Oregon Revised Statutes 75.710, Variation of Implied Obligations .....	41

## TEXTS

44 A.L.R. 229.....	37
65 A.L.R. 649.....	27
108 A.L.R. 1502.....	33
108 A.L.R. 1488.....	37
3 Am. Jur., Appeal & Error, Section 1029.....	40
12 Am. Jur., Contracts, Section 410.....	31
12 Am. Jur., Contracts, Section 427.....	28
46 Am. Jur. 674, Sales, Section 515.....	41
46 Am. Jur., Sales, Section 791.....	28
46 Am. Jur., Sales, Section 791 at p. 919.....	34
49 Am. Jur., Statute of Frauds, Sections 321 and 325 .....	30
53 Am. Jur., Trial, Section 98.....	40
53 C.J. 1206, Section 20.....	31
8 R.C.L. 442.....	33
Webster's New International Dictionary, 2nd Ed.....	34
Williston on Sales, Section 71e.....	30



**United States**  
**COURT OF APPEALS**  
**for the Ninth Circuit**

---

H. P. WILLMAN, Doing Business as POPPERS  
SUPPLY CO.,

*Appellant,*

vs.

HAROLD M. ALVER, OSCAR J. ALVER,  
RAYMOND N. ALVER, LUCILE M. AL-  
VER, JEANNETTE B. ALVER and MIL-  
DRED M. ALVER, a Co-partnership Doing  
Business as Premier Popcorn Company,

*Appellees.*

---

**APPELLANT'S BRIEF**

---

*Appeal from Final Judgment of the United States  
District Court for the District of Oregon.*

HON. CLAUDE MCCOLLOCH, Judge.

---

**JURISDICTION**

Jurisdiction of the action in the District Court prop-  
erly attached because the pre-trial order in paragraph 3,  
under agreed facts (R. 8), sets forth the diversity of  
citizenship and amount in controversy under 28 U.S.C.A.  
Section 1332.

Final judgment in the case was filed December 10, 1956 (R. 29). Notice of Appeal was filed January 3, 1957 (R. 31), and a supersedeas bond filed on January 4, 1957 (R. 32). The appeal has been taken in time under Federal Rules Civil Procedure, rule 73, 28 U.S.C.A. This Court has jurisdiction of the appeal under 28 U.S.C.A. Section 1291.

### **STATEMENT OF THE CASE**

This is an action for damages for an alleged breach of a sales contract, involving the sale of corn which was to have been shipped in monthly installments. The action was brought by the Premier Popcorn Company, the seller, located in Watseka, Illinois, against H. P. Willman, doing business as Poppers Supply Co., Portland, Oregon, the buyer. The Premier Company is a processor of corn, purchasing it from the farmers and selling it to wholesale distributors. The Poppers Supply Co. is a wholesale distributor. A verdict was directed for the plaintiff Premier Company, the seller, and the defendant buyer appeals.

The appellant had been buying corn for some time from the appellee (R. 72). On May 11, 1953, the parties entered into a written contract for 7200/100 lb. bags of corn at the price of \$9.00 a bag, F.O.B. Watseka, Illinois, including bags (Ex. 1). The contract called for shipments of 600 bags per month, beginning October, 1953, and extending for a period of twelve months. The quantity was subsequently reduced by mutual agreement to 3600 bags, or six cars of corn. The last six cars were can-

celled. There is no dispute about the reduction in quantity (Exs. 2 and 4).

On or about October 12, 13 or 14, 1953, the appellant buyer was in Chicago and talked with the appellee seller about the corn market generally (R. 39-40). The buyer told the seller that the corn market was going down and asked for some relief on the contract price (R. 63). The seller said he would talk to his partners about it (R. 40).

On October 23rd, the seller in Watseka, Illinois, telephoned the buyer in Portland, Oregon. According to the testimony of the buyer, the seller agreed to reduce the price of the corn from \$9.00 to \$8.00 a bag (R. 63), with the proviso that if the market went up again, the contract price would be followed.

On that same day, October 23rd, the seller wrote the buyer a letter (Ex. 3) in which the seller stated:

“As to the contract dated May 11, 1953, we will hold this contract in abeyance and ship you popcorn for the time being at a price of \$8.00 per hundred weight, including the bag F.O.B. our plant.”

The buyer, upon receipt of this letter, understood it to be a confirmation of his understanding of the telephone conversation (R. 64). The seller now claims that neither the telephone conversation nor his letter of October 23rd were a reduction in the contract price. The seller now maintains that he meant that he would sell the buyer what the seller refers to as “open market” corn for the \$8.00 price (R. 41-42).

In November, 1953, the seller came to Portland and reduction in price was discussed again (R. 65). The

seller now contends that this conversation dealt only with an \$8.00 price on so-called "open market" corn (R. 43). The buyer and his salesman were both at the meeting and testified that the seller again confirmed the \$8.00 contract price (R. 66 and R. 77). Neither the buyer nor his salesman heard the words "abeyance" or "open market corn" mentioned in this conversation (R. 65, 67, 77).

By letter of December 15, 1953 (Ex. 4), the buyer notified the seller that he was exercising his right to cancel six cars in accordance with the seller's letter of May 20, 1953 (Ex. 2). On December 22, 1953, the seller wrote the buyer a letter (Ex. 5), stating that the contract of May 11, 1953, could no longer be held in abeyance, and asked for shipping instructions for the October, November and December shipments, and enclosed an invoice for three cars of corn at \$9.00 F.O.B. Watseka, Illinois, the original contract price. This letter was received by the buyer on January 4, 1954 (R. 10). The buyer phoned the seller on January 5, 1954, and questioned him about the invoice and the price on it (R. 68). The buyer testified that the seller said that he was going back to the original contract price of \$9.00 (R. 68). On that same day, January 5, 1954, the buyer sent a purchase order (Ex. 7) to the seller, giving shipping instructions for two cars of corn at \$9.50 F.O.B. Portland which is \$8.00 F.O.B. Watseka, Illinois (R. 47). No corn was shipped on this purchase order

On February 2, 1954, the buyer sent a purchase order to the seller (Ex. 11), for the entire six cars of corn at \$8.00 F.O.B. Watseka, Illinois but there was no response to this purchase order and no corn was ever shipped.

On February 11, 1954, the buyer telegraphed the seller (Ex. 12), notifying the seller that the buyer was completely out of corn and must know by return wire if corn was being shipped under the buyer's purchase order of February 2, 1954. There was no response to this wire.

The seller filed suit, claiming breach of contract by the buyer in failing to order the corn at the original contract price.

Trial was had before a jury, and, after motion by the plaintiff for a directed verdict (R. 85), the Court directed the jury (R. 90 et seq.) to find a verdict for the plaintiff and to assess the damages. The jury determined the damages to be \$10,800 for which sum judgment (R. 29) was entered and the buyer appeals. The jury apparently found the damages to be \$3.00 per bag on 3600 bags, or the difference between the contract price of \$9.00 and a market price of \$6.00, which was the seller's testimony as to market price in February, 1954 (R. 52).

### **STATEMENT OF APPELLANT'S SPECIFICATION OF ERRORS**

(1) That the District Court erred in directing a verdict for the appellee, and in finding, as a matter of law, that the contract between the appellee and appellant had neither been modified nor rescinded when the evidence in its most favorable light to the appellant, demonstrated that the question of whether or not the contract had been modified or rescinded was a question of



fact for the jury; and the Court erred in failing to give the instructions requested regarding modification or rescission.

At the close of the testimony, counsel for appellee moved for a directed verdict as follows (R. 85):

“I move the Court to instruct the jury that the defendant has not established a defense that the contract was modified by subsequent agreement as to price on the ground that such an agreement would be in violation of the statute of frauds and that there was no considerations supporting any such agreement and, therefore, as a matter of law the defendant has not established that defense.”

The Court, after hearing arguments on this motion and a motion for dismissal by the appellant's counsel's made the following statement (R. 88):

“The Court: This case has had a hectic career. I don't imagine what I am going to say is going to be satisfactory. I know it isn't all around. It isn't the kind of case that I enjoy, because the result, it seems to me, that is impelled by the record is really not equitable. The law of sales in the commercial world has never really been equitable.

“After reflection overnight, taking these papers home with me and reading them both last night and this morning, I don't see anything much to submit to this jury. I can't follow you gentlemen on your claim that there is a rescission, a question of rescission to be submitted to the jury. That is not your testimony. Your testimony is that the contract was modified, not rescinded. Your client's two orders there at the end, when he was taking his position—and these people, no doubt under a lawyer's advice at the time, were squaring off to take the position—the last two orders are definitely related to the contract, and they purport to be under the contract of

May, 1953. So very clearly it seems to me that what you were saying at that time was that you recognized that the contract was still in existence but it had been modified as to price and you were ordering under the contract but at a lower price.

“That is where you get into legal difficulties, it seems to me, because you have to rely upon an oral modification of the contract except as you claim something for that letter with the word “abeyance” in it. That is the only writing that you can claim supports your modification theory. I just don’t read that letter the way you claim for it.

“So in my view of the case the plaintiff is entitled to a directed verdict, with only one question for the jury and that is the amount of damages, to whatever extent you differ there.”

The Court then instructed the jury, in part, as follows (R. 94):

“Now you will have one form of verdict: ‘We, the jury in the above-entitled matter, find our verdict for the plaintiffs in the sum of blank dollars.’”

The appellant requested the following instruction, which was not given (R. 25):

“A written contract may be rescinded and superseded by a new contract by the express or implied agreement of the parties, and, likewise, a written contract may be modified by subsequent agreement of the parties.

“This rescission or modification may be oral or partly oral and partly written, even though the original contract be in writing. Therefore if you find that the plaintiffs’ letter of October 23, 1953, and the oral conversations of the parties, either taken separately or considered together, amounted to a rescission of the original contract and the making of a new contract at a price of \$8.00, or a modification

of the old contract so that the price was changed to \$8.00, then you must find your verdict against the plaintiffs and for the defendant, for it is uncontradicted that defendant offered to buy corn at \$8.00.”

The appellant took exception to the direction of verdict and to the failure of the Court to give the requested instruction (R. 95):

“Mr. Reynolds: The defendant objects to the direction that the jury find a verdict for the plaintiffs, and then objects to the failure of the Court to give the instructions submitted.”

The Court overruled the exceptions, stating as follows (R. 96):

“The Court: The exceptions have been considered and respectively overruled.”

(2) That the District Court erred in failing to direct the jury that it should give due consideration to mitigation of damages, and in failing to give the appellant’s requested instructions concerning mitigation of damages. The appellant requested the following instructions requesting mitigation of damages (R. 27, 28):

“The law imposes upon a party injured by another’s breach of contract the active duty of using all ordinary care and making all reasonable exertions to render the injury as light as possible. Therefore, if you find that the defendant made a bona fide offer to buy corn at \$8.00 per bag, then that may be taken into your consideration in assessing damages, if you find that plaintiff is entitled to any damages. Thus if you find that defendant was required to accept 1800 bags, or 3 monthly installments, under the contract, plaintiff’s damages would be limited to \$1.00 per bag, or \$1800.00. If you find that defendant was required to accept 3600 bags,

then the damages, under this theory, would amount to \$3600.00.”

and

“If you find that the original contract was neither modified nor rescinded, then you must consider the quantity of corn which the defendant was required to accept under the original contract. The words ‘in abeyance’ as used in plaintiffs’ letter of October 23, 1953, mean: ‘Temporarily inactive, suspended or suppressed; temporarily without manifest existence’ or ‘a condition of being undetermined.’ Since the plaintiff’s letter terminating the period of abeyance did not reach defendant until the time for performance had passed as to the first three months, you must limit your consideration of damages to the last 3 cars, or 1,800 bags of corn.”

The basis for the foregoing instructions was set forth in the trial memorandum submitted by the appellant’s counsel to the Court.

The Court’s charge respecting damages (R. 90 et seq.), which is set forth in totidem verbis in paragraph (3) below, makes no reference to mitigation of damages in any respect.

The appellant took exception to the failure of the Court to give the instructions requested (R. 95):

“Mr. Reynolds: The defendant objects to the direction that the jury find a verdict for the plaintiffs, and then objects to the failure of the Court to give the instructions submitted.”

The Court overruled the exceptions stating as follows (R. 96):

“The Court: The exceptions have been considered and respectively overruled.”

(3) That the District Court erred in failing to direct the jury to find damages based upon the market price at the time and place of delivery, and in directing the jury that damages be based upon the market price in either January or February, 1954, when the contract was for deliveries in installments beginning in October, 1953, and in failing to give the defendant's requested instructions concerning this aspect of the case; and further that the verdict is contrary to the law of damages.

The appellant requested the following instructions (R. 26, 28):

"With respect to a contract for future delivery of merchandise, the rule of general damages is that on refusal of the buyer to take the property, the seller is entitled to recover the difference between the contract price and the lesser market value of the goods at the time and place of delivery. Therefore if you find that the original contract was neither rescinded nor modified, and that the defendant breached the contract, then the maximum amount which plaintiff would be able to recover would be the difference between the contract price of \$9.00 per hundred pound bag and the market price during October, November and December, 1953, and January, February, and March, 1954, computed on 600 bags for each of those months, except however, that plaintiff was required to mitigate his damages, as stated in other instructions."

and

"If you find that the original contract was neither modified nor rescinded, and if you do not limit plaintiffs' damages to \$1.00 per bag, then you must consider the measure of damages based on market value, and since the market price was falling, it will make a difference as to what months you use. In this connection I instruct you that when



plaintiff notified defendant that the contract could no longer remain in abeyance, the legal effect of this was to place the parties back in their original position, and you should start with the market price in October, 1953, and use the market price for each succeeding month to compute the damages as to each 600-bag car.”

The Court’s charge respecting damages is as follows (R. 90 et seq.):

“The Court: Ladies and Gentlemen, the plaintiffs’ theory about the damage here is that in the month of January the parties came to the end of this transaction in the sense that at that time—that is one possibility, according to the plaintiffs’ way of looking at it—the buyer the man down here at the end of the table, made it definitely plain that he was not going to go ahead with the deal, so that the damages should be calculated as of that time and the damages would be the difference between the contract price which was \$9.00 per 100 pounds and what the then market price was. The parties differ as to what the market price was. The plaintiff says it was then \$6.50; that it had fallen to \$6.50 per hundred pounds, whereas, as you see over there, the defendant say it had not fallen that much at that time; that it had only fallen to \$7.25. So if that is the method in which the damages should be figured, the damages would come out differently on account of the difference between the parties as to what the then market was.

“Those are the first two figures that I suggest you write down. If you take the \$6.50 market figure, which is the plaintiff’s idea, as of that month the damages would be \$9,000, if that is the method to use, whereas if you take the defendant’s idea of the market, which is a good deal higher, or \$7.25, the damages would be less. They would be \$6,300.

“That is one of the things you may have to resolve in the case. Now, then, if February is the

month to take, if that is the month when in fact the parties came to the end of their transaction, by a definite rejection by the buyer of the contract, you have two figures again to deal with because of the difference between the parties as to what the market price then was. As you see on the board, the plaintiffs' idea was that the market had fallen to \$6.00, or \$3.00 less than the contract price. And since the amount in dispute was 3,600 bags, that is one thing we can figure out. Three times 3,600 bags would be \$10,800. That would be the damages if that was the month you took and if that was the market price you took.

“The defendant again thinks that the market was higher in that month than the plaintiff does. His idea was it was \$6.75, as you see. So that is going to make the damages less in that month if that is the month you take, and that figure comes out, so the gentlemen have told me, to \$8,100 rather than \$10,800.

“If you accept the line of reasoning that the attorney for the defendant has presented to you, as he has shown you down there at the foot of the board, the damages are \$6,000, and we get still another figure. In fact, he says they should be reduced by the number of bags involved at the price per bag, coming to \$900.00, which drops it to \$5,100.

“So you have six possible choices. And the gentleman for the plaintiff who was just speaking took a different view about the bags, so that would make a \$7.00 figure.

“I don't know whether I am making this very plain to you. It is pretty mixed up, but that is the way these commercial transactions get sometimes.

“In the few brief remarks I am going to make I am going to start with the line of reasoning that Mr. Stirling, representing the defendant, presented to you: That the damages should be figured on each

month, beginning back in October when the first delivery was to be taken. His theory comes out pretty plainly when you look at those two figures up there. He says that there was no damage in that month because, according to his figure over there, the market was still the \$9.00 contract price. And he says that that was the month that this man had agreed to take the corn, and he didn't take it, so the damages should be computed as of that time for that monthly quota, and so on clear through.

"I am not going to say that you have to reject that theory altogether, but I am just going to make this comment, which I feel privileged to do. I think that disregards what the parties were doing. You will find a letter in here written in October where the seller is telling the buyer that he will hold the contract in abeyance. There are some differences here about what 'abeyance' means. That just shows you better use a simple word when you can and sometimes you come out better. But we have got that word to deal with, and my idea is that that meant an extension. That is what he was saying: 'I am not going to ask you to take deliveries because the market has gotten soft, and we will put off to some indefinite time in the future further discussion about this contract.' I read 'abeyance' to mean an extension of time. So I don't see how you can say that the damages shall be figured in October when the quota for that month had been extended to a future indefinite time. *It seems to me that the correct theory in the case is either in January or February*, when the parties squared off to have a row over this and got their affairs in the hands of their lawyers, as you will see from the correspondence. *That is the time to take.* And you will see, as has been argued to you, that the buyer was taking the position in January which indicated that he claimed the contract had been amended and he was not going to observe it, and then you will find the same thing in February. It seems to me your choice is between those months. And that then puts

you back to a choice between the differing figures that result from the different sides as to what the market was in those months.”

The appellant took exception to the Court’s charge respecting this matter as follows (R. 95):

“Mr. Reynolds: The defendant objects to the direction that the jury find a verdict for the plaintiffs, and then objects to the failure of the Court to give instructions submitted.

“Further, we except to the Court’s instructions on any theory of damages other than the \$6,000 or the \$5,100 figure based on the computation using the months of October, November, December, January, February and March for the reason that the Court has ruled that the contract was neither modified nor rescinded by the negotiations nor the letter of October 23rd, and it seems to us, therefore, that the effect of that ruling must be to give no effect to those negotiations or letter, which would put us back to the original position of the parties, so that the maximum damages must be arrived at by using the figures starting with October, either the figures used by the plaintiffs or by the defendant.”

The Court denied exceptions as follows (R. 96):

“The Court: The exceptions have been considered and respectively overruled.”

(4) That the District Court erred in admitting testimony of the appellee over objection of counsel for appellant, respecting a prior unrelated contract between the parties, which testimony was extremely prejudicial to the appellant.

On redirect examination of the appellee, the appellee’s counsel was asking the appellee how he happened

to remember the contents of a telephone conversation between the appellee and the appellant on January 5, 1954, and the appellee answered as follows (R. 60):

“Well, we had just finished prior to October delivering Mr. Willman 7,200 bags of corn. He had paid us a price of \$9.00 during the year 1952. At that time the market price was \$12.50, and we delivered to him every pound of that corn. He was buying it at \$3.50 under the market price, and we saved him approximately \$25,000 in the previous year. And now the minute the market dropped——

Mr. Reynolds: Your Honor, just a minute——

The Court: He may continue. He may tell his story.

The Witness: Now that the market dropped a dollar under \$9.00 he refused to take the corn.”

(5) That the District Court erred in failing to grant appellant’s motion for dismissal. At the close of the testimony, the appellant moved for a dismissal of the case as follows (R. 87):

“Mr. Reynolds: That this time, your Honor, the defendant moves for a dismissal of this case on the basis that the contract itself provides certain remedies available to the seller in the event of a breach. Those remedies are set forth in the contract.

“It is this paragraph: ‘Buyer shall furnish seller complete shipping instructions at least ten days before the stated shipping time for each installment. If buyer fails to give seller shipping instructions as required herein then at the expiration of the stated shipping time seller may at seller’s option and without notice (a) hold the goods and invoice the buyer for the same or (b) extend the time of shipment or (c) be excused from delivering the balance of the goods or continuing the performance of the contract.’

“Our position is that they are limited to the



rights granted them under the contract, and in this case they do not proceed on any of those bases.”

The Court, without specifically denying the motion, notified the parties that it was going to direct a verdict for the plaintiff.

### **SUMMARY OF ARGUMENT**

The District Court erred in directing a verdict for plaintiff seller against defendant buyer on a contract for the sale of corn, to be shipped in installments, for the reason that the evidence was in dispute as to whether or not there was a reduction in price, and such was a question of fact for the jury to decide; and for the further reason that directed verdict is to be granted only when there is no substantial evidence supporting the party against whom it is directed, and there is substantial evidence that the contract price was reduced.

And if the contract was not modified or rescinded, the District Court erred in failing to instruct the jury to give consideration to mitigation of damages for the reason that the buyer was led to believe that the contract price had been reduced, and ordered out the corn at the reduced price, and the seller thus had the opportunity to sell the corn to the buyer at \$1.00 per bag under the original contract price but no corn was shipped, and the Court ignored these facts, and directed the jury to find damages based on the difference between the contract price and market price at a time when the market price was considerably less than \$1.00 per bag under the contract price, and, in fact, the jury found a verdict on a

market price which was \$3.00 per bag less than the contract price.

That the District Court erred in failing to direct the jury to give consideration to mitigation of damages also for the reason that the contract was, at least, suspended for a period of time, and the buyer cannot be held liable for corn that was to have been shipped during that suspended period.

If the contract was neither modified, nor rescinded, then the District Court erred in failing to direct the jury to find damages based upon the difference between the contract price and the market price during the period set out in the contract, namely, October, November, December, 1953, January, February and March, 1954, and erred in instructing the jury that damages could and, in fact, should be based upon the market price in either January or February, 1954, and the jury's verdict based upon a February market price is contrary to law, for the reason that, in an installment contract, damages are based upon the time set for delivery, which was during the months of October, 1953, through March, 1954, or if that is not the basis used, then damages are based upon the time of the buyer's refusal to accept, which was no later than January, 1954.

The District Court erred in allowing testimony of the seller regarding a prior contract which was entirely irrelevant and extremely prejudicial to the buyer in that the seller, by his testimony, attempted to show that he gave the buyer a price much lower on the prior unrelated contract than the then market price, and thereby prejudiced the jury against the buyer.

That the District Court erred in failing to grant the buyer's Motion for a Dismissal on the ground that the seller, under the contract, had certain remedies for breach of contract, and that the seller was limited to those remedies by the contract and by his invoicing of the corn to the buyer, but that none of the remedies provided therein were followed by the seller in this action.

## **ARGUMENT**

### **Point 1**

#### **The Court Erred in Directing a Verdict for the Plaintiff-Appellee, and Therefore, in Taking from the Jury the Question of Whether or Not the Contract Had Been Modified or Rescinded**

**A. Upon a Motion for a Directed Verdict for the Plaintiff, the Motion Admits the Truth of the Defendant's Evidence and of Every Inference of Fact That Can Reasonably and Legitimately Be Drawn Therefrom, and All the Evidence Must Be Interpreted in the Light Most Favorable to the Defendant.**

In the case of *National Molasses Co. v. Herring*, 221 F. 2d 256, a buyer of molasses brought action against seller for breach of contract, wherein the issue was whether the contract between the parties was evidenced (1) by a purchase order from the buyer which permitted ordering through the month of September or (2) by a confirmation of sale sent by seller to buyer, which fixed September 1st as a cut off date for ordering shipments. The District Court directed a verdict for the plaintiff buyer, and the 8th Circuit Court reversed, holding:

“The Trial court was evidently convinced that the plaintiff had proved conclusively that the defendant had accepted the terms of the ‘purchase order,’ and was, as a matter of law, liable to plaintiff for the breach of the contract. The difficulty with that conclusion is that, *in determining whether the plaintiff was entitled to a directed verdict, the District Court was required to view the evidence in the light most favorable to the defendant and most unfavorable to the plaintiff, and to give to the defendant the benefit of every inference that reasonably could be drawn in its favor.* The general rules for determining whether a trial court was justified in directing a verdict have been so fully and so frequently stated that there is no justification for repeating them. What frequently seems to be overlooked in cases such as this is that where inconsistent inferences reasonably may be drawn upon from undisputed evidentiary facts, it is for the jury, and not the court, to determine which inference shall be drawn.”

In the case of *Western Auto v. Sullivan* 210 F 2d 36 the plaintiff seller was, as here, suing the defendant buyer for breach of contract for failure to order out glycol as agreed, and the defense of rescission or modification was raised. The defendant buyer contended that the price had been lowered by mutual agreement, based upon telephone conversations and a letter from defendant buyer to plaintiff seller. The 8th Circuit Court of Appeals held that the following charge to the jury by the District Court was correct in such case:

“It is for you to determine whether or not there was a rescission or abandonment or modification of the original written contract. In determining this question, you may take into consideration not only all the testimony of the witnesses regarding the understanding arrived at in conversations, but also the

conduct of the parties in the light of the surrounding circumstances, and the inference may be drawn from such conduct and circumstances that a rescission, cancellation, or modification had been agreed upon between the parties.”

In *Aetna Casualty Co. v. Yeatts*, 122 F. 2d 350, it was held that a verdict can be directed only where there is no substantial evidence to support recovery by the party against whom verdict is directed, or where the evidence is all against such party or so overwhelming so as to leave no room for doubt what the fact is.

The State of Oregon follows the general rule respecting directed verdicts, holding that “the party against whom the motion for a directed verdict is directed is entitled to the benefit of every reasonable inference that can be drawn from the evidence.” *Gresham Transfer, Inc., v. Oltman*, 187 Or. 318, at 320, 210 P. 2d 927.

#### WHAT DOES THE EVIDENCE IN ITS MOST FAVORABLE LIGHT TO DEFENDANT SHOW AS TO A MODIFICATION OR RESCISSION OF CONTRACT?

The parties discussed lowering the contract price in October, 1953, in Chicago, because the market price of corn had dropped. The plaintiff stated that he would take it up with his partners (R. 40). The defendant confirmed this (R. 63).

Later, the parties had a telephone conversation, the exact context of which is in dispute. There is no dispute, however, that the parties did talk about a price of \$8.00. The plaintiff’s version of that call is as follows (R. 41):



“A. I called Mr. Willman regarding delivery of a car of corn that was left over from the previous year’s contract. It was a car of corn that had sold to him for \$12.50 in addition to his regular contract corn, and he asked me for a reduction in price on that particular car of corn. I gave him a \$2.00 reduction because of the fact we were already in the new crop of corn and we were getting the new crop of corn cheaper. And then he asked me for a reduction on the May 11th contract from \$9.00 to \$8.00, which I refused to give him. However, I told him that if he wanted to buy some \$8.00 open market corn we would hold up delivery on the contract corn for the time being and sell him some \$8.00 open market corn.”

The defendant’s version of the call is this (R. 63):

“A. On October 23rd, Mr. Alver called me and he says, ‘Mr. Willman, I have talked it over with my partners and’ he says, ‘we will’—he asked me if this would be satisfactory to me: He says, ‘We will reduce the price on the one 800-bag car that we had coming from a previous contract’—that they would reduce the price from \$12.50 f.o.b. Portland to \$10.50 f.o.b. Portland. And he said on the May 11th contract that, for the time being, they would lower the price from \$9.00 to \$8.00 f.o.b. Watseka, with this provision: That if the market price went back up to \$9.00 they would want then to go back to the \$9.00 price. He asked me if that was agreeable and I said it was. I asked him to give me a letter in writing to that effect.”

It should be noted that the foregoing was a telephone call from the seller to the buyer, following the request of the buyer, about 10 days earlier for a price reduction. The plaintiff seller did not have to make such a call.

The letter of October 23rd from the plaintiff seller to defendant buyer followed. It recites as follows (Ex. 3):

“As to the contract dated May 11, 1953, we will hold this contract in abeyance and ship you popcorn for the time being at a price of \$8.00 a hundred-weight, including the bag, f.o.b. our plant.”

The term “abeyance” to the plaintiff apparently meant holding up the contract indefinitely. When a contract is held up indefinitely and another price substituted, is not that obviously a new contract at the new price with a condition attached, the condition being that when the market goes up, the price goes up also? Plaintiff’s cross-examination shows (R. 56):

“Q. Now, as to the length of time that you would hold up the May 11th contract, was there any specific time ever set, Mr. Alver?”

A. No specific time was set. We had in mind January 1st, holding it up for three months. That had been mentioned. However, no time had been set for the holding up of the \$9.00 contract.

Q. That January 1st time was not mentioned to Mr. Willman, though?

A. In our conversations it had been mentioned, I believe.

Q. Isn’t it a fact that you were actually prepared to hold up that contract almost indefinitely?

A. *If the occasion had arose, I imagine we would have held it longer than that had Mr. Willman purchased his monthly requirements at the market price.*

Q. You mean at the market price or at the \$8.00 price?

A. At the \$8.00 price.”

The term “abeyance” to the defendant meant that if the market went up, the contract price of \$9.00 would be reinstated, as evidenced by his testimony, supra R. 63. And that is the logical and practical conclusion.

The term "open market corn" is used by the plaintiff seller in his testimony, presumably meaning that he would ship corn at \$8.00, outside, or over and above the contract. Plaintiff even went so far as to say he used the term "open market corn" in both his telephone call and letter of October 23rd (R. 42).

It was obviously not used in the letter (Ex. 3). And the defendant testified that nothing about "open market corn" was stated in the telephone call, and that the first time it was mentioned was in the trial of this case (R. 65). The defendant also testified that the word "abeyance" was never uttered or discussed (R. 67).

In a falling market, the buyer had no need for corn outside the contract, and the seller's position now that he was willing to sell corn to the buyer in addition to what the buyer had ordered under the contract, at \$8.00, is, as a practical matter, ridiculous.

The next meeting between the parties was in November, 1953, when the plaintiff came to the defendant's office in Portland. The plaintiff testified as follows of that meeting (R. 43):

"Q. Was the May 11th, 1953, contract, Plaintiffs' Exhibit No. 1, discussed at this time in November?

A. Yes; it was.

Q. Do you recall what was said and by whom?

A. Mr. Willman asked me for a price reduction in the contract. He wanted me to ship him some of the contract corn at \$8.00 instead of \$9.00, which I refused to do. I still said that he could buy some \$8.00 open market corn if he wished. However, we insisted that he take out the 3,600 bags at \$9.00 on the contract corn."

It should be noted that in the above testimony, the plaintiff said he was insisting on the defendant taking out "3600 bags," whereas, at that date the agreement was still for 7200 bags, the cancellation being made later by defendant in his letter of December 15th (Ex. 4).

The defendant's version of this November conversation is as follows (R. 65):

"Q. During that visit did you have any conversation with him concerning the contract price under this May 11th contract?

A. Yes. We talked about the amount of corn that was grown in 1953, and again we talked about changing the contract, and right along this same line the same thing was said once more, that he would change the price on the contract from \$9.00 to \$8.00, but again he specified this one point, that in the event the market price of corn went up he would want to go back to \$9.00 price. And I told him that was very agreeable.

Q. In that conversation was there any mention of the January 1st date to return to the contract price?

Q. *Was there any mention of when any of the corn under the May 11th contract should be shipped?*

A. *It was not discussed at that time, because on November 6th we had just unloaded the last car of the previous contract. Mr. Alver and I both knew that it takes 30 to 45 days to get rid of a car of corn, which would put us into the first of January before we would be able to order out any more corn."*

The defendant's salesman was present during the foregoing conversation and verifies the defendant's version (R. 77 and R. 79).

There follows the December 15th letter of cancellation of 6 cars of corn by the buyer (Ex. 4). It seems more than coincidental that soon thereafter, December 22nd, the seller wrote to the buyer requesting shipping instructions on 3 cars of corn for October, November and December, 1953 (Ex. 5), and enclosed an invoice for all three cars at the original contract price of \$9.00.

The defendant phoned the plaintiff on receipt of that letter and asked why the \$9.00 price (R. 68):

“A. I called Mr. Alver and I asked him if he was further reducing the price of the corn 50 cents a bag. Mr. Alver says he was not. He said he was going back to the original contract price. I asked Mr. Alver why he was going back to the \$9.00 price rather than the \$8.00 price, and all Mr. Alver would say was that he was simply going back to the \$9.00 price.

Q. Was there anything said in that conversation concerning shipping instructions under the contract?

A. Mr. Alver did ask us to explain our position to him, and we did put it in writing by sending through a purchase order for two cars of corn at that very same date.”

The defendant subsequently sent purchase orders for all 3600 bags at the \$8.00 price (Ex. 7 and 11), but the orders were ignored and no corn was shipped.

The evidence, in its most favorable light to the defendant, therefore, demonstrates that there was a lowering of the price from \$9.00 to \$8.00 per bag, and that the defendant complied with the new or revised agreement by ordering out all the corn at the \$8.00 price.



**B. Whether or Not the Contract Was Rescinded or Modified Was a Question of Fact for the Jury.**

1. *The General Principle Is That When There Is a Dispute as to Whether or Not a Written Contract Has Been Modified or Rescinded, It Is a Question of Fact, or, at Least, a Mixed Question of Law and Fact, for the Jury to Decide.*

In *H. R. Wyllie China Co. v. Vinton*, 192 P. 400, 97 Or. 350 at p. 363, it is held:

“We do not think that the court can say as a matter of law, after an inspection of the writings, that the agreement was as claimed by the plaintiff or as contended for by the defendant; but it was appropriately a question for the jury to decide what the parties intended, after viewing the writings in the light of the course of dealing followed by the parties, and in the light of the accompanying circumstances.”

*Cuneo Press v. Claybourn Corp.*, 90 F. 2d 233.

*Empire Box Corp. v. Jefferson Island Salt Mining Co.*, 36 A. 2d 40 (Del.).

*John H. Maclin Peanut Co. v. Pretlow*, 11 S.E. 2d, 607 (Va).

*Standard Rice Co. v. Sims*, 119 S.W. 2d, 1035 (Ark).

*Keeter v. Griffith*, 241 P. 2d 213 (Wash.).

*Krauter v. Simonin*, 274 F. 791.

In *Fulton v. Henrico Lumber Co.*, 148 S.E. 576 (Va.), it is stated:

“While the general rule is that documents must be constructed by the Court and should not be submitted to a jury, there are exceptions to this rule. Cases frequently arise in which the parties have by parol modified their written contract, or where there are obscurities which may be clarified by parol tes-

timony, or where the document to be construed is ambiguous and cannot be proved without proof of the attendant circumstances by parol testimony. If there be material conflicts in such admissible parol testimony, it frequently occurs that the interpretation of the documents become a mixed question of law and fact, which it is necessary to submit, as to the questions of fact, to the jury, with proper instructions."

The jury should certainly have been given the opportunity of determining just what the letter of October 23, 1953 (Ex. 3), meant in the light of the disputed evidence concerning it and the conversations of the parties, prior and subsequent thereto.

In 65 A.L.R. 649, it is stated:

"It has been quite uniformly recognized that, where a written contract is ambiguous, and extrinsic evidence as to intention has been introduced, there does exist within the province of the jury some function as to the construction of the contract."

Justice Cardozo held, in *Utica City National Bank v. Gunn*, 118 N.E. 607 (N.Y.):

"The triers of the fact must fix the sense in which the words were used in the contract."

Furthermore, "Where language of written contract is ambiguous, it must be construed most strongly against the person who prepared the document and caused the uncertainty to exist." *Fischer v. Means*, 198 P. 2d 389 (Cal.).

The seller, in this case, was the writer of the "abeyance" letter (Ex. 3).

2. *It Was Proper and Competent for the Parties to Modify Their Contract or to Rescind the Contract and Enter into a New Agreement.*

“Under the general principles of the implied rescission of contracts by the making of a new inconsistent agreement with respect to the subject matter of the old contract, it would seem on principle that entering into a new and inconsistent contract of sale with respect to the same subject matter while the old contract is unexecuted, constitutes an implied rescission of the contract.” 46 Am. Jur., Sales, Section 791.

“It is entirely competent for the parties to a contract to modify or waive their rights under it and ingraft new terms upon it. The parties to a contract ordinarily are as free to change it after making it as they were to make it in the first instance, notwithstanding provisions in it designated to hamper such freedom.” 12 Am. Jur. 1004, Contracts, Section 427.

3. *The Statute of Frauds Does Not Preclude a Modification or Rescission in This Case.*

Oregon Revised Statutes: “75.040 (1) Statute of Frauds. A contract to sell or a sale of any goods or choses in action exceeding the value of \$50 shall not be enforceable by action unless the buyer shall accept part of the goods or choses in action so contracted to be sold or sold, and actually receive the same, or give something in earnest to bind the contract, or in part payment, or unless some note or memorandum in writing of the contract or sale be signed by the party to be charged or his agent in that behalf.”

The District Court held and the appellee apparently contends that the letter of October 23, 1953 (Ex. 3), is not a sufficient “memorandum in writing signed by the

party to be charged." The Court stated as follows (R. 89):

"That is where you get into legal difficulties it seems to be me, because you have to rely upon an oral modification of the contract except as you claim something for that letter with the word "abeyance" in it. That is the only writing that you can claim supports your modification theory. I just don't read that letter the way you claim for it."

The letter (Ex. 3), states "As to the contract dated May 11, 1953, we will hold the contract *in abeyance* and ship you popcorn for the time being at a price of \$8.00 cwt including the bag f.o.b. our plant."

The original contract price was \$9.00 a cwt (Ex. 1). The defendant's testimony (R. 63), is that the plaintiff notified the defendant by telephone prior to the above quoted letter that the plaintiff was reducing the price to \$8.00, but that if the market price went up, the contract price returned to \$9.00, and when the letter (Ex. 3) arrived, the defendant took no other meaning from it than that the contract price was being reduced to \$8.00, subject to a rise if the market went up (R. 65). Subsequent to the letter, the plaintiff came to Portland, and, according to the defendant's testimony (R. 66), further verbally confirmed the lower price of \$8.00 on the contract, and stated again that if the market price went up, the plaintiff wanted to go back to the \$9.00 price. The latter is what the defendant believes the plaintiff intended by the word "abeyance."

Assuming the appellant's interpretation of the letter to be the proper interpretation, as should be done upon a motion for a directed verdict, is it not then a sufficient

writing within the Statute of Frauds, when considered in the light of the parties' conversations?

"No particular form of language or instrument is necessary to constitute a memorandum or note in writing under the Statute of Frauds." 49 Am. Jur. Statute of Frauds, Section 321.

"The memorandum required to satisfy the Statute of Frauds may be found to exist in the form of a letter." 49 Am. Jur., Statute of Frauds, Section 325.

Or, it may be determined that there was a new oral contract entered into between the parties, exclusive of the letter of October 23, 1953.

Upon this basis, the Statute of Frauds would be a bar to a counter-claim by the appellant but the oral contract is available to the appellant in this suit by way of a defense. Williston on Sales, Section 71e.

Furthermore, the seller may be estopped from setting up the Statute of Frauds. Looking at the testimony again, in its most favorable light to the buyer, the seller led the buyer to believe that there was a reduced price on the contract (R. 63, 65, 66, 67, 72).

"He, who by his language or conduct, leads another to do what he would not otherwise have done, shall not subject such person to loss or injury by disappointing the expectation upon which he acted. Such a change in position is sternly forbidden." *Dickerson v. Colgrove*, 100 U.S. 578, 25 L. Ed. 618.



4. *An Executory Contract May Be Modified Without Consideration, But Even in This Case, Consideration for a Modification Was Present.*

*12 Am. Jur., Contracts, Section 410, states that any executory contract which is bilateral in the advantages and obligations given and assumed may, at any time after it has been made and before a breach thereof has occurred, be changed or modified in one or more of its details by a new agreement also bilateral, by the mutual consent of the parties without any other consideration.*

In case brought by a seller of poultry by carload against a buyer, it was held that "While a transaction is in fieri, or a contract is executory, the parties by mutual assent may abandon the transaction, or rescind the contract, or they may modify or alter the terms of the contract. No other consideration is necessary than the mutual assent of the parties." *E. T. Gray & Sons v. Satuloff Bros.*, 105 So. 666 (Ala.); *Penney v. Burns*, 146 So. 611 (Ala.); 53 C.J. 1206, Sec. 20.

People in business know that contracts are modified as to price as a regular occurrence, particularly by a seller to a buyer, in order to retain that buyer's future business.

One case has been found on that point, and in that case it was held that, where the parties had had business dealings over a period of years, the hope of retaining the customer's good will and his future business was sufficient consideration for a material change in a sales contract. *Marx v. Leichner*, 121 So. 685 (La.).

And a modification of a contract by a seller agreeing to reduce price for a period on condition of return to contract price thereafter was held based upon consideration. *Clayton Oil & Refining Co. v. Langford*, 293 S.W. 559 (Tex.).

And in a case involving the sale of corn to be shipped at the rate of 2 cars a month, it was held that an executory contract can be modified by an agreement to pay an increased ceiling price on the corn, and the modification contains consideration, since the buyer had the right to decline further performance and let the seller sue for damages, and the buyer's relinquishment of that right in executing the modification was sufficient consideration. *Ellis Gray Milling Co. v. Sheppard*, 215 S.W. 2d 57 (Mo.).

## **Point II**

### **The District Court Erred in Failing to Direct the Jury That It Should Give Due Consideration to Mitigation of Damages.**

**A. That If the Contract of May 11, 1953, Is Deemed to Have Remained in Effect, Under the Doctrine of Mitigation of Damages, Appellee Is Limited to Damages of \$1.00 Per Bag, for the Reason That Appellant Submitted Purchase Orders for the Corn at \$8.00, and the Appellee Refused to Recognize Such Purchase Orders.**

Oregon Revised Statutes "75.640 — Action for Damages for non-acceptance of goods.

"(1) Where the buyer wrongfully neglects or refuses to accept and pay for the goods, the seller may maintain an action against him for damages for non-acceptance.

“(2) The measure of damages is the estimated loss directly and naturally resulting, in the ordinary course of events, from the buyer’s breach of the contract.”

The buyer, of course, contends that he did not repudiate the contract and certainly did not wrongfully neglect or refuse to accept and pay for the goods, at least, at \$8.00. The evidence shows that the seller had returned to and was holding out for the \$9.00 original contract price when the buyer forwarded his purchase orders (Ex. 7, 11). Thus, the seller could have minimized the damages by selling at \$8.00 and holding the buyer responsible for the difference.

It is a fundamental rule that one injured as a result of a tort or of a breach of contract is bound to exercise reasonable care and diligence to avoid loss or to minimize the resulting damage, and that, to the extent that his damages are the result of his active and unreasonable enhancement thereof, or are due to his failure to exercise such care and diligence, he cannot recover. 8 R.C.L. 442; 108 A.L.R. 1502. See also *Hastings Stout Co. v. Bennett*, 130 S.E. 334 (S.C.).

In a case involving the refusal of a seller to deliver lumber, except upon modified terms, in discussing the question of mitigation of damages, the court said, “We see no reason, as a matter of law, why the rule requiring the damaged party to minimize his damages as far as he reasonably can do so should exclude an obligation to buy from the party breaching the contract, if purchase can be made from him that will minimize the loss without abandoning the contract, or waiving any right

of action for damages for a breach growing out of it" *Borden & Co. v. Vinegar Bend Lumber Co.*, 2 Ala. App. 354, 56 So. 775, and reiterated in the same case in 7 Ala. App. 336.

It has also been held that if, after a breach by the buyer, by his wrongful refusal to accept, the seller re-sells to him for a less price, this is not a rescission of the old contract so as to defeat the seller's right to recover, as damages for the wrongful refusal to accept, the difference between the original price and the price paid on the resale; in such a case, it has been held immaterial that no notice was given by the seller to the buyer of his intention to hold the buyer for the difference. 46 Am. Jur., Sales, Section 791 at p. 919; *Arkansas & T. Grain Co. v. Young*, 96 S. W. 142 (Ark.); *E. T. Gray & Sons v. Satuloff Bros.*, 105 So. 666 (Ala.).

**B. If the Contract of May 11, 1953, Is Deemed to Have Remained in Effect, and the Contract Was Held in Abeyance by Appellee's Letter of October 23, 1953, During the Months of October, November and December, 1953, Then the Contract Became One for 1800 Bags, or 3 Cars Only, and Damages Must Therefore Be Based Upon a Contract for 1800 Bags.**

The appellee, by his own interpretation of the letter of October 23, 1953, states that the letter meant that shipments under the contract would be indefinitely suspended (R. 56).

"Abeyance" means "Temporarily inactive, suspended, or suppressed; temporarily without manifest existence." Webster's New International Dictionary, 2d Edition.

In other words, the contract was without manifest existence during the period of its abeyance, and the obligation of the appellant to purchase corn under the contract from the appellee during October, November and December, 1953, ceased.

Unless this meaning is given to the letter of October 23, 1953, it has no meaning whatsoever, except as a rescission or modification of the contract.

In the case of *J. C. Engelman v. Sanders Nursery*, 140 S.W. 2d 500 (Tex.), in which the contract was modified to provide for shipments at a later indefinite date, it was held there was no longer a contract at all: "On an indefinite contract neither liquidated damages nor the damages contemplated by law resulting from a breach can be recovered,—in short, there is no contract to be breached."

### Point III

#### **The District Court Erred in Failing to Direct the Jury to Find the Damages Based Upon the Market Price at the Time and Place of Delivery, or at Any Appropriate Time, and the Jury's Verdict Is Contrary to Law**

If it is found, as the District Court held, that the original contract (Ex. 1), had neither been rescinded nor modified, and, if no consideration is to be given to the "abeyance" letter, at least as a suspension of the contract, for at least 3 months, then the parties are placed in their original position, with a contract for 6 cars of corn, one car to be shipped each month, begin-



ning in October, 1953, and ending in March, 1954, and damages should have been computed upon the difference between the market price and the contract price, at the time and place of delivery, i.e., the sum total of the difference on each car for each of these months. Both the buyer and seller were qualified to testify as to the market price and their testimony was as shown below:

	Contract Price	Buyer's Market Estimate (R. 73)	Seller's Market Estimate (R. 52)	Buyer's Diff.	Seller's Diff.
Oct. '53 .....	\$9.00	\$9.00	\$8.00	none	\$1.00
Nov. '53 .....	9.00	8.00	8.00	1.00	1.00
Dec. '53 .....	9.00	7.00	7.00	2.00	2.00
Jan. '54 .....	9.00	7.25	6.50	1.75	2.50
Feb. '54 .....	9.00	6.75	6.00	2.25	3.00
March '54 ....	9.00	6.00	6.00	3.00	3.00

Upon the foregoing, it can be seen that the damages, when based upon the sum total of the difference between market price and contract price during the months of October, 1953, through March, 1954, would be as follows:

	Based on Buyer's Figures		Based on Seller's Figures	
Oct.	600 bags x none	no damage	600 bags x \$1.00	\$ 600.00
Nov.	600 bags x \$1.00	\$ 600.00	600 bags x 1.00	600.00
Dec.	600 bags x 2.00	1200.00	600 bags x 2.00	1200.00
Jan.	600 bags x 1.75	1050.00	600 bags x 2.50	1500.00
Feb.	600 bags x 2.25	1350.00	600 bags x 3.00	1800.00
Mar.	600 bags x 3.00	1800.00	600 bags x 3.00	1800.00
		Total		Total
		\$6000.00		\$7500.00

The seller considered the contract to be in effect from October on, because his letter and invoice (Ex. 5), of December 22, 1953, definitely show that he was holding the buyer to the original shipping dates. In that letter the seller demanded that the buyer give shipping instructions for the October, November and December ship-

ments at the original contract price of \$9.00. And on January 5, 1954, the seller was still insisting on the original shipments (R. 56).

The measure of damages when the buyer breaches a contract of sale for delivery in installments is computed upon the difference between the market price and contract price at the time and place of delivery of each installment.

44 A.L.R. 229; 108 A.L.R. 1488.

Scruggs v. Riddle, 171 Ala. 350, 54 So. 641.

Newton v. Bayless Fruit Co., 155 Ky. 440, 159 S.W. 968.

Gentile Bros. Co. v. Rose, 7 F. 2d 879, 6th Circ.

Simons v. Ypsilanti Paper Co., 77 Mich. 185, 43 N.W. 864.

Smith & Co. v. Russek, 212 F. 2d 338 (5th Circ.).

In *California Sugar & White Pine Co. v. Whitmer Jackson & Co.*, 263 P. 504 (N.M.), the court approved an instruction directing the jury that, inasmuch as the goods were to be delivered in installments they should find the market value of each installment, the difference between that sum and the contract price being the damages on that installment, and that the total damages would be the sum of the damages on all the installments.

In any event, the Court erred in instructing the jury that it could determine all the damages, as of the market price in February, 1954, and the jury's verdict is contrary to law, because the verdict is apparently based upon a February market price.

Oregon Revised Statutes—"75.640. Action for damages for nonacceptance of goods. (1) Where the buyer wrongfully neglects or refuses to accept and

pay for the goods, the seller may maintain an action against him for damages for nonacceptance.

“(2) The measure of damages is the estimated loss directly and naturally resulting, in the ordinary course of events, from the buyer’s breach of contract.

“(3) Where there is an available market for the goods in question, the measure of damages is, in the absence of special circumstances showing proximate damage of a greater amount, the difference between the contract price and the market or current price at the time or times when the goods ought to have been accepted, or, if no time was fixed for acceptance, then at the time of the refusal to accept.”

Thus, if the time or times for acceptance is not used as a basis for computation or damages, or if no time for acceptance is established, then the damages are determined as of the time of refusal to accept. *Engraw v. Schenley Distilleries*, 181 F. 2d 876.

The refusal of the buyer to accept the corn, according to the seller’s own testimony, occurred no later than January 5, 1954, when the buyer told the seller he would buy no corn at \$9.00 (R. 46), and may be deemed to have occurred during either October, November or December, 1953, when the buyer did not order out corn for those months. It appears that the seller considered the contract breached in December, when he wrote his letter (Ex. 5), demanding shipping instructions.

The seller cannot, after receiving notice of cancellation of sale by the buyer, by urging the latter to reconsider his refusal to accept the goods, hold the latter liable for a subsequent fall in the market price of the goods.

Franklin Sugar Refining Co. v. Lykens Mercantile Co.,  
117 A. 780 (Pa.).

In *La Grange Grocery Co. v. Lamborn*, 283 Fed. 869, the measure of damages was held to be the difference between the contract price and the highest market price on the day when the seller notified the buyer that, unless shipping directions were given within a certain length of time, the seller would regard the contract as breached, the buyer having failed to give shipping instructions.

#### Point IV

### **The District Court Erred in Admitting Testimony of the Seller Over Objection of Counsel for Buyer, Respecting a Prior Unrelated Contract Between the Parties, Which Testimony Was Extremely Prejudicial to the Buyer**

On redirect examination of the appellee, the appellee's counsel was asking the appellee how he happened to remember the contents of a telephone conversation between the appellee and the appellant on January 5, 1954, and the appellee answered as follows (R. 60):

"Well, we had just finished prior to October delivering Mr. Willman 7,200 bags of corn. He had paid us a price of \$9.00 during the year 1952. At that time the market price was \$12.50, and we delivered to him every pound of that corn. He was buying it at \$3.50 under the market price, and we saved him approximately \$25,000 in the previous year. And now the minute the market dropped—

"Mr. Reynolds: Your Honor, just a minute—

"The Court: He may continue. He may tell his story.

“The Witness: Now that the market dropped a dollar under \$9.00 he refused to take the corn.”

The seller was obviously making a determined effort by his testimony to prejudice the jury against the buyer, by claiming that in the previous year the buyer had had a contract which was under the market price. That may or may not have been true, but it had no bearing of any kind on the case at issue. The Court should have stricken the testimony and instructed the jury to disregard it, but instead of that, the Court encouraged the seller to “tell his story.” (R. 60)

Such testimony encouraged by the court to be told was no doubt one of the prime factors in the jury’s determination of damages.

“The trial court may and should exclude immaterial, irrelevant and incompetent evidence which tends to confuse and mislead the jurors by diverting their attention from the real issue—Evidence which serves only to prejudice the minds of the jury is properly excluded.”

53 Am. Jur., Trial, Sec. 98.

3 Am. Jur., Appeal & Error, Sec. 1029.

### **Point V**

#### **That the District Court Erred in Failing to Grant Appellant’s Motion for Dismissal**

The Contract (Ex. 1), provided in part as follows:

“If Buyer Fails to give Seller shipping instructions as required herein then at the expiration of the stated shipping time Seller may at Seller’s option and without notice (a) hold the goods and invoice the Buyer for same or (b) extend the time



of shipment or (c) be excused from delivering the balance of the goods or continuing the performance of the contract.

The above contract set forth the rights of the seller in event of default, and while the remedies provided are not specifically made exclusive, that is certainly the fair interpretation of the language, particularly since the last clause of the contract (Ex. 1), states that the contract expresses the entire agreement of the parties. And doubt must be resolved against the seller, since the contract is on his printed form.

That the seller considered his remedies to be as provided in the contract and not under the general law of sales is readily apparent. When he decided to enforce the contract he invoiced three cars (Ex. 5, R. 10), which he was entitled to do under (a) above, but not under the Sales Act. And once he exercised his option to so proceed as to part of the contract, he was bound to continue in the same manner as to the balance. See 46 Am. Jur. 674, Sales, Sec. 515, which gives the law as follows:

“When the contract of sale is broken, the seller, having the choice of remedies, is put to an election, and having made one, and having dealt with a portion of the property left in his possession in accordance with that remedy, he must pursue the same remedy as to the whole \* \* \*.”

The parties may by agreement vary the law that would otherwise apply. Oregon Revised Statutes, Sec. 75.710, which is similar to Sec. 71 of the Uniform Sales Act, provides:

“Variation of implied obligations. Where any right, duty or liability would arise under a contract

to sell or a sale by implication of law, it may be negatived or varied by express agreement or by a course of dealing between the parties, or by custom, if the custom be such as to bind both parties to the contract or the sale.”

In *Christian Mills v. Berthold Stern Flour Co.*, 247 Ill., App. 1, the seller brought suit for damages computed according to the terms of the contract. The buyer claimed that damages should be based on usual rules of law. The contract provided: “On breach of contract by buyer, liquidated damages shall be recoverable by seller as follows: \* \* \*.” The Court at p. 13 stated: “\* \* \* The formula which pertained to the measurement of the seller’s damages should have been recognized in the trial of the case as lawful and properly binding upon both parties \* \* \*”

In *Permutit Co. v. Massasoit Mfg. Co.*, 61 F. 2d 529, the contract set forth some warranties but did not negative others. At p. 530 there is this language: “The authorities overwhelmingly established the doctrine that, where the parties have set out in the written contract the warranties agreed upon and have provided for a remedy in case of a breach of warranty, the remedy thus provided is exclusive.”

Certainly the above theory should apply equally to a breach of any other kind. Here the contract provided for three remedies, and those should be held to be exclusive.

The complaint was based on a remedy not provided for in the contract, hence the buyer’s motion to dismiss should have been allowed.

## CONCLUSION

For the reasons stated herein it is submitted that the judgment of the District Court should be reversed.

Respectfully submitted,

JOHN F. REYNOLDS,  
Equitable Building,  
Portland, Oregon,

J. P. STIRLING,  
3128 N. E. Broadway,  
Portland 12, Oregon,

Attorneys for Appellant.



United States  
**COURT OF APPEALS**  
for the Ninth Circuit

---

H. P. WILLMAN, Doing Business as POPPERS  
SUPPLY CO.,

*Appellant,*

vs.

HAROLD M. ALVER, OSCAR J. ALVER,  
RAYMOND N. ALVER, LUCILE M. AL-  
VER, JEANNETTE B. ALVER and MIL-  
DRED M. ALVER, a Co-partnership Doing  
Business as Premier Popcorn Company,

*Appellees.*

---

**APPELLEES' BRIEF**

---

*Appeal from Final Judgment of the United States  
District Court for the District of Oregon.*

HON. CLAUDE MCCOLLOCH, Judge.

---

FILED

M. H. CLARK,  
WILLIAM E. TASSOCK,  
Yeon Building,  
Portland 4, Oregon,

*Attorneys for Appellees.*

MAY 20 1957

PAUL P. O'BRIEN, CLERK





## INDEX

	Page
Jurisdiction .....	1
Statement of the Case.....	2
Summary of Argument.....	5
Argument:	
Re Appellant's Point I.....	7
Re Appellant's Point II.....	14
Re Appellant's Point III.....	15
Re Appellant's Point IV.....	19
Re Appellant's Point V.....	19
Conclusion .....	22

## INDEX OF CASES

	Page
Callaghan v. Scandlin, 178 Or. 449, 167 P.2d 119.....	8
City of Erlanger v. Berkemeyer, 207 F.2d 832 .....	21
Craswell v. Biggs, 160 Or. 547, 86 P.2d 76.....	8
D'Aprile v. Turner-Looker Co., 239 N.Y. 427, 38 A.L.R. 1426 .....	20
James River Lumber Co. v. Smith Bros., 116 S.E. 241 .....	16, 17
Krebs Hop Co. v. Livesley, 59 Or. 574, 586, 114 P. 944 .....	14
Lee v. Blockland, 122 Or. 230, 257 P. 801.....	20
Maddaloni Olive Oil Co. v. Aquino, 191 App. Div. 51, 180 N.Y.S. 724 .....	8
Neppach v. Ore. & Cal. R. R. Co., 46 Or. 374, 80 P. 482 .....	15
Osborn v. Eldriedge, 130 Or. 385, 280 P. 497.....	15
Potter Realty Co. v. Derby, 75 Or. 566, 147 P. 548 ...	20
Reid v. Diamond Plate Glass Co., 54 U.S. App. 619, 85 Fed. 193.....	8
Scott v. Hubbard, 67 Or. 398, 136 P. 653 .....	15
Sorenson v. U. S., 226 F.2d 460 .....	21
Teuscher v. Utah-Idaho Flour & Grain Co., 221 P. 1096 .....	16, 17
Urbansky v. Kutinsky, 84 A. 317, 86 Conn. 22 .....	20
Warren v. A. B. Mayer Mfg. Co., 161 Mo. 112, 61 S.W. 644 .....	8

## INDEX OF TEXTS

A.L.I. Rest. of Law of Contracts, Sec. 223(2).....	8
A.L.I. Rest. of Law of Contracts, Sec. 224.....	8
Oregon Revised Statutes, Sec. 75.040 .....	9
Williston on Contracts, Sec. 593, N. 1, p. 1705.....	8, 12
Williston on Contracts, Sec. 595, p. 1710.....	8, 9

United States  
**COURT OF APPEALS**  
for the Ninth Circuit

---

H. P. WILLMAN, Doing Business as POPPERS  
SUPPLY CO.,

*Appellant,*

vs.

HAROLD M. ALVER, OSCAR J. ALVER,  
RAYMOND N. ALVER, LUCILE M. AL-  
VER, JEANNETTE B. ALVER and MIL-  
DRED M. ALVER, a Co-partnership Doing  
Business as Premier Popcorn Company,

*Appellees.*

---

**APPELLEES' BRIEF**

---

*Appeal from Final Judgment of the United States  
District Court for the District of Oregon.*

HON. CLAUDE MCCOLLOCH, Judge.

---

**JURISDICTION**

Appellees concur with the Jurisdictional statements  
on pages 1 and 2 of Appellant's Brief.

## STATEMENT OF THE CASE

This is a seller's action against a buyer for breach of a contract of purchase. In defense, the Defendant primarily relies upon either the assertion that the parties agreed to lower the price stated in the contract or the assertion that the contract was rescinded.

The Plaintiffs are co-partners engaged in the popcorn processing business in Watseka, Illinois. In the spring of the year, they contract with the farmers to grow popcorn for delivery in the fall at a fixed price, and, at the same time, they contract with wholesale distributors such as the Defendant for delivery of processed popcorn in the fall at a fixed price which is related to the price stated in the contracts with the farmers (R. 36).

In the spring of 1953 (May 11), the Plaintiffs contracted to sell, and the Defendant contracted to buy, 7200 - 100 lb. bags of popcorn, at a price of \$9.00 a bag f.o.b. Watseka, Illinois (Ex. 1). The contract provided that the popcorn was to be delivered in installments of 600 bags per month, commencing with the month of October, 1953. The parties, in writing, mutually agreed to cancel the last six installments (Exs. 2-4).

The 1953 crop was a large one and in the fall of 1953, the farmers delivered their popcorn, amounting to 20,700,000 pounds, to the Plaintiffs as agreed (R. 39) and, about that time, in October of 1953, the time slated for the first delivery under the contract, the market price dropped below the \$9.00 contract price (R. 40).



On October 23, 1953, Plaintiffs mailed Defendant a letter (Ex. 3), which read as follows:

“Confirming our telephone conversation today, we will ship next week the balance of your contract dated December 31, 1952, 800 bags, at a price of \$10.50 f.o.b. Portland instead of the price of \$12.50 as stated in the contract.

“As to the contract dated May 11, 1953, we will hold this contract in abeyance and ship you popcorn for the time being at a price of \$8.00 cwt. including the bag f.o.b. our plant.”

Note: Plaintiffs had received 1953 crop corn which was purchased at lower prices, hence Plaintiffs could lower the price on the one car mentioned above (R. 41).

On December 15, 1953 (when open market corn was selling for \$7.00—R. 52) Defendant wrote Plaintiffs a letter (Ex. 4) wherein inter alia, he complained about the fall in the market price of corn and his sales position, but made no mention of a purported reduction in the contract price.

On December 16, 1953, Plaintiffs mailed Defendant a letter (Ex. 13) informing Defendant of Plaintiffs' financial difficulties and of pending arrangement proceedings in the Federal Bankruptcy Court, by reason of which there was “no pressure upon us to deliver popcorn at reduced prices,” and assuring Defendant that Plaintiffs would be able to carry out the contract.

By January 2, 1954, Defendant had ordered no popcorn at \$8.00 or \$9.00 and Plaintiffs mailed (R. 45 and Pretrial Order) Defendant a letter (Ex. 5) notifying Defendant that Plaintiffs could no longer hold the contract in abeyance.

On January 11, 1953 (when corn was selling at \$6.50 on the open market—R. 52), Plaintiffs received Defendant's purchase order (Ex. 7) which read, in part, as follows:

"Ship 1 . . . car of popcorn from sales contract dating May 11, 1953 . . . the price of this corn to be \$9.50 f.o.b. Portland as you quoted last *November* . . . Do not ship under any other terms.

The price stated in the above order is equivalent to \$8.00 f.o.b. Watseka (R. 58).

On January 28, 1954, Plaintiffs' attorney wrote Defendant insisting upon performance of the contract, and advising that the previous purchase order did not comply (Ex. 8).

On February 2, 1954 (when corn was selling in the market at \$6.00—R. 52), Defendant sent another purchase order (Ex. 11) for six cars of corn at a price of \$8.00, which purported to be in compliance with the "contract dated May 11, 1953, as amended . . . *Oct. 23, 1953.*" On the same day, Defendant's attorney wrote (Ex. 10), declaring it necessary "to regard the contract as discontinued . . . if the purchase order (Ex. 11) was not confirmed." The two purchase orders (Exs. 7 and 11) constitute Defendant's only attempts to perform the contract of May 11, 1953, and were submitted with knowledge that Plaintiffs had rejected Defendant's claim of right to purchase under the contract at \$8.00, and the Plaintiffs were insisting on performance at \$9.00 (R. 71).

Based upon Defendant's repudiation of the contract, Plaintiffs brought suit in April of 1954 for breach of

the contract. At the conclusion of the third trial, it appeared from the pleadings, pretrial order and evidence that the only defenses asserted by Defendant was that the original contract had been (1) modified, as a result of negotiations occurring in October and November of 1953, so as to reduce the price from \$8.00; or (2) impliedly rescinded when the parties entered into the alleged, unenforceable, oral contract to modify it.

At the conclusion of the trial, Plaintiffs requested the Court to instruct the jury that the Defendant had failed to establish a defense because: (1) the evidence of an oral agreement to modify the original contract was incompetent under the Statute of Frauds and failed to show that any consideration supported any alleged agreement; and (2) because there was no evidence that the parties intended to rescind the contract.

The Court in effect granted Plaintiffs' request, and the jury, accepting Plaintiffs' and rejecting Defendant's testimony as to market values, returned a verdict based upon the finding that Defendant's conduct in February, 1954 (Exs. 10 and 11) constituted a repudiation of the contract of May 11, 1953.

### **SUMMARY OF ARGUMENT**

It is Plaintiffs' view that the words—

“As to the contract dated May 11, 1953, we will hold this contract in abeyance and ship you popcorn for the time being at a price of \$8.00 per hundred weight, including the bag, F.O.B. our plant.”

cannot, as a matter of law, be construed to mean that the writer agreed to change the price stated in the contract of May 11, 1953, from \$9.00 to \$8.00.

If Plaintiffs' view is correct, there was no competent evidence from which the jury could find that the parties had agreed to modify the contract as to price. The Statute of Frauds precludes such a finding based upon oral conversations.

There was no evidence that the parties intended a rescission unless a rescission was to be presumed from the evidence that the parties entered into an unenforceable oral agreement. It is clear under the authorities that a rescission, which is to take effect only as a part of an oral agreement to modify a contract within the statute, is likewise ineffective. Moreover, as pointed out by the trial judge, the defense of rescission was clearly not available because Defendant's evidence clearly showed that none was intended.

Defendant's offer to purchase corn at \$8.00, conditioned upon Plaintiffs' acceptance of said offer as full performance of the \$9.00 contract, is not evidence mitigating the damages.

The evidence of both parties conclusively showed that the time for delivery under the contract of May 11 was extended for an indefinite period. Under such circumstances, damages are determined when performance insisted upon by one party is followed by a subsequent repudiation of any obligation by the other. The jury found that the Defendant repudiated the contract in

February and computed damages accordingly. There was sufficient evidence upon which to base such a finding. Moreover, the Court's instructions permitted the jury to find the damages based upon the time stated in the contract. This was more than the Defendant was entitled to and the Court's comments discrediting this theory were nothing more than permissible comments on the evidence.

The testimony of the Plaintiffs as to prior contracts and dealings was relevant. Furthermore, such evidence was received without objection by the Defendant, was invited by Defendant's own cross-examination, and related to matters which Defendant himself introduced into evidence.

The subject contract does not purport to provide an exclusive remedy; hence Plaintiffs were entitled to bring an action for damages.

## **ARGUMENT RE APPELLANT'S POINT I**

The Court did not err in taking from the jury the question of whether or not the contract had been modified as to price, or rescinded.

### **Points and Authorities**

A contract which is required to be in writing by the Statute of Frauds cannot be modified by subsequent oral agreement. (This rule not applicable to variations in time of performance—See Point III, post.)



Callaghan v. Scandlin, 178 Or. 449, 167 P2d 119.  
 Craswell v. Biggs, 160 Or. 547, 86 P.2d 76.  
 Williston on Contracts, Sec. 593, N. 1, p. 1705.

With exceptions not applicable here, such oral modifications are no defense to an action on the original contract.

A.L.I. Rest. of Law of Contracts, Sec. 223 (2):

“If a contract to vary a prior contract or to substitute another contract in its stead is unenforceable because of failure to satisfy the requirements of the Statute, the prior contract is not thereby rescinded, or, except as stated in Sec. 224, varied.”

Williston on Contracts, Sec. 595, p. 1710:

Admitting, as a Court must admit, that the writing proves the only contract which can be enforced, any defense *in pais* to that contract can be shown which is *not based* on the enforcement of a parol agreement as such.”

Maddaloni Olive Oil Co. v. Aquino, 191 App. Div. 51.

Warren v. A. B. Mayer Mfg. Co., 161 Mo. 112, 61 S.W. 644.

Reid v. Diamond Plate Glass Co., 54 U.S. App. 619, 85 Fed. 193.

## Argument

### (a) RE MODIFICATION AS TO PRICE.

The Defendant does not appear to seriously quarrel with the law as stated above. He suggests (App. Br. p. 30) that the case falls within the exception recognized by Williston (and Restatement of the Law of Contracts, Sec. 224), to-wit, a case where “Plaintiff is seeking to

enforce the contract and the Defendant to excuse himself from liability sets up an oral agreement or statement by which the performance for which Plaintiff sues was prevented," Williston on Contracts, Sec. 595, at 1710; but, he points out no way in which Defendant was prevented from performing. Defendant does not and could not urge that Plaintiffs prevented Defendant from purchasing corn under the contract at \$9.00, when the market price was lower (R. 51 and 52) when the Plaintiffs had more corn than they could store (R. 84) and when Plaintiffs ultimately disposed of the balance of the 1953 crop in 1955 at a distressed price of \$4.75 (R. 54).

We take it that it is also recognized that the Statute of Frauds is a rule of substantive law, and not simply a rule of evidence. Oregon Revised Statutes, Sec. 75.040, provides that an oral contract, coming within its terms, "shall not be enforceable by action unless" . . . certain exceptions appear. Hence, in the absence of proof of an exception, a Court must instruct a verdict irrespective of the amount of evidence in the record tending to prove an oral agreement. We trust that Defendant is not contending that a motion for a directed verdict, based upon the Statute of Frauds, admits the validity of an oral contract declared to be "unenforceable" by the Statute.

We assume that the Defendant is contending that a jury question is framed where there is a writing in evidence which Defendant asserts to be a sufficient memorandum of the modifying agreement. It is the Plaintiffs'

contention that no such jury question arises if the subject writings cannot, as a matter of law, be construed to have the necessary meaning.

It well may be that it is proper for a court in some cases to permit a jury to construe writings; for example, where, as in the cases cited by Defendant, the writings are susceptible to the meaning asserted; but, the Statute of Frauds would be a nullity if a party need only *assert* that a writing has a particular meaning in order to have a jury act on oral evidence of a contract.

It is Plaintiffs' contention, and the trial court's conclusion, that the letter of October 23, 1953 (Ex. 3) cannot in any event be construed to mean that the writer was agreeing to deliver merchandise under the contract of May 11, 1953 (Ex. 1) at a reduced price of \$8.00.

The "contract dated May 11, 1953" is in evidence (Ex. 1). The "contract" contains, *inter alia*, provisions describing the quality and quantity of the subject matter, the price of same, the time for sending shipping instructions, and the times of delivery. The Appellant, however, seems to suggest that the word "contract" means "price," because, for Defendant to prevail, the subject language must be construed substantially as follows:

"As to the contract (here Defendant seems to admit that 'contract' refers to the instrument as a whole, including all of its terms and provisions) dated May 1, 1953, we will hold this contract (here Defendant wants 'contract' to mean 'price') in abeyance and ship (here Defendant must insert 'under the contract') you popcorn for the time being at a price of \$8.00 per hundred weight, including the bag, F.O.B. our plant."

The commercial world would lose much of the essential certainty and stability that the Statute of Frauds is designed to secure if relations can be so capriciously altered.

Incidentally, Defendant's conduct was grossly inconsistent with the interpretation that he now seeks to place upon the letter, that is, he did not order any popcorn during October, November and December, as would be required if only the price stated in the original contract had been held in abeyance. Moreover, it is significant to note that Defendant himself did not interpret the letter of October 23 to mean a modification of the contract because he first relied upon something alleged to have occurred in November. (See Exhibit 7, dated January 5, 1954, where he submits a purchase order under the contract as modified in *November*). It was not until counsel appears in the picture that reliance is had on a necessary writing. (See Exhibits 11 and 10, when under date of February 2, 1954, a modification in October is asserted.)

We wish to make it clear that the Plaintiffs strenuously deny the truth of Defendant's testimony, and Plaintiffs are confident that a detailed analysis of the record would show that Plaintiffs never made the agreement asserted by the Defendant. The fact that the jury returned the highest possible verdict supports this view. In view of the state of the record, however, it is not believed to be appropriate to discuss such matters in detail. Suffice it to say, that the Plaintiffs' conduct was reasonable and practical under the circumstances. Plaintiffs could not give up the advantages of the contract

because of pre-existing obligations to the farmers, but the Plaintiffs could permit Defendant to purchase his immediate requirements at the market price, thus assisting Defendant if the market should go back up within a reasonable time.

(b) RESCISSION.

There is no evidence whatsoever that the parties intended to rescind the original contract. To the contrary, and as the trial court pointed out to the Defendant:

“Your testimony is that the contract was modified not rescinded. Your client’s two orders there at the end, when he was taking his position . . . the last two orders are definitely related to the contract and they purport to be under the contract of May, 1953. So very clearly it seems to me that what you were saying at that time was that you recognized that the contract was still in existence but had been modified as to price and you were ordering under the contract but at a lower price.”

(See Exhibits 7 and 11, and R. 58 and 59, for the terms of these orders.)

The only way to say that there was a question of rescission for the jury, is to say that the jury was entitled to imply a rescission from the evidence that the parties entered into an oral agreement to modify the original contract as to price. Such a rule would, of course, do away with the well accepted rule that an oral contract to modify a contract, which is required to be in writing by the Statute of Frauds, cannot be a defense to an action on the written contract. As Professor Williston points out, Section 593 of the Revised Edition of Williston on Contracts:



“Though an oral agreement to rescind without more could be effectual . . . where the rescission is to be effected only as a part of an entire agreement to substitute a new contract differing in terms from the old one, there can be no rescission if the agreement as a whole is unenforceable.”

As indicated, there is not even any evidence of an oral agreement to rescind unless the same arises by implication from the making of the unenforceable agreement to modify.

(c) RE LACK OF CONSIDERATION.

Defendant's alleged promise to do something less than what he was legally bound to do is not consideration in the legal sense. This rule of Hornbook Law undoubtedly has lost favor in these modern times, but we submit that it is good law, and that it is applicable to the case at bar.

(d) RE ESTOPPEL.

Defendant, very briefly (bottom of page 30 of Appellant's Brief), suggests that the Plaintiffs are estopped from setting up the Statute of Frauds. This marks the first occasion that Defendant has made this assertion, and, under the authorities cited, post, it cannot now be considered. However, there is no evidence that Plaintiffs represented that a writing would not be required, or that the Statute of Frauds would not be relied upon. Moreover, there is no evidence that the Defendant changed his position to his detriment in reliance upon any oral representations.

## ARGUMENT RE APPELLANT'S POINT II

(A) The Court did not err in refusing to instruct that Defendant's conditional offer to buy at \$8.00 should be considered in mitigation of damages.

You will note from Exhibits 7 and 11 that the Defendant's offer to purchase at \$8.00 was conditioned upon Plaintiffs' giving up any right to insist upon \$9.00. It is obvious that such a conditional offer cannot be considered in mitigation of damages. It would be novel indeed if a Defendant could limit a Plaintiff's recovery by making a compromise offer. The extent to which the Oregon Court goes to protect a Plaintiff from such maneuvers is seen in *Krebs Hop Co. v. Livesley*, 59 Or. 574, 586, 114 P. 944, where the Defendant's offer was not even *expressly* conditional as in the case at bar.

Defendant obviously submitted these purchase orders in an attempt to compel the financially distressed Plaintiffs to accept something more than they could obtain on the open market (the market price in January was \$6.50, February \$6.00), but something less than the amount to which they were entitled. And surely, Plaintiffs would have been better off to accept Defendant's offer back in February of 1954, rather than take the risk of litigation and endure these years of expense and delay, but such a course would have meant submission to intimidation.

(B) The Court did not err in refusing to instruct that Plaintiffs were entitled to damages for three months only.

We are dealing with a contract providing for the sale of 600 bags of popcorn for each of six successive months, commencing in October, 1953. The contract as a whole was held in "abeyance." Appellant argues (pp. 34-35 of his Brief) that, as a matter of law, "abeyance" meant that the contract was cancelled with respect to any month that corn was not purchased. Aside from the fact that "abeyance" simply does not mean "cancelled," this argument is manifestly inconsistent with Appellant's conduct, to-wit, he insisted under purchase order (Ex. 11) that in February, 1954, he had the right to purchase corn for six successive months. In fact, in a prior action, he carried out the threat contained in Exhibit 10 and counterclaimed for damages caused by Plaintiffs' failure to accept the purchase order.

### **ARGUMENT RE APPELLANT'S POINT III**

The Court's instructions as to the time for determining the damages were in accordance with the law, and the jury's verdict was based upon competent evidence.

#### **Points and Authorities**

1. While the terms of a contract which is within the Statute of Frauds cannot be varied by an oral agreement, the time for performance of such contracts can, by an oral agreement, express or implied, be extended.

Osborn v. Eldriedge, 130 Or. 385, 280 P. 497.

Neppach v. Ore. & Cal. R.R. Co., 46 Or. 374, 80 P. 482.

Scott v. Hubbard, 67 Or. 398, 136 P. 653.

2. Where a buyer acquiesces in an extension of time for performance and such buyer subsequently refuses to perform within a reasonable time after requested to do so by seller, the damages are determined as of the time the buyer refuses to perform and repudiates the contract.

Teuscher v. Utah-Idaho Flour & Grain Co., 221 P. 1096.

James River Lumber Co. v. Smith Bros., 116 S.E. 241.

The Court was confronted with several possibilities for fixing the time for determining the damages:

(1) The possibility that the damages should be determined as of the times stated in the original contract. As shown in Appellant-Defendant's Brief, page 36, on the basis of Plaintiffs' evidence of market value (and the jury accepted Plaintiffs', rejected Defendant's, testimony on this point), the damages would be \$7500.00 based upon these times.

COMMENT: The Court's instructions (R. 92-93) permitted the jury to return a verdict based upon this theory, notwithstanding the undisputed fact that the Defendant had acquiesced in the extension of time for shipment and the law to the effect that, under such circumstances, damages are to be determined when the buyer ultimately repudiates the contract. That is, if one completely disregards all of the oral evidence pertaining to price, it is still undisputed that the Defendant acquiesced in the extension of time for shipment by ordering no corn at any price prior to January, and by his testimony (R. 66) that both parties understood, irre-

spective of price, that he would not be required to take delivery prior to January. In *Teuscher v. Utah-Idaho Flour Co.*, 221 P. 1096, and *James River Lumber Co. v. Smith Bros.*, 116 S.E. 241, the damages were determined as of the time the Defendant ultimately repudiated, Defendants having acquiesced in the extension of time for delivery. This is only proper—why should the Defendant be permitted to remain silent submitting no purchase orders and take the benefit of a later market rise, and insist that he does not have to take the disadvantages of a later market decline? However, the Court instruction permitted the jury to accept the Defendant's argument and it would seem that the Defendant cannot now complain because the jury did not accept it.

(2) The possibility that the damages should be determined over a period of six consecutive months, i.e., the contract as extended was one requiring Defendant to take a car for each of six consecutive months, commencing at an uncertain time; hence damages should be determined commencing at the time of the Defendant's refusal to accept. Under this theory, the damages would be (assuming the jury accepted Plaintiffs' market value, as was the case):

January	600 x 2.50	\$ 1,500	
February	600 x 3.00	1,800	\$ 1,800
March	600 x 3.00	1,800	1,800
April	600 x 3.50	2,100	2,100
May	600 x 3.50	2,100	2,100
June	600 x 4.00	2,400	2,400
July	600 x 4.00	_____	2,400
Refused in January		\$11,700	_____
Refused in February			\$12,600



(3) The possibility that the Defendant anticipatorily breached his contract to take 600 bags for six consecutive months, when he clearly repudiated any intention of performing it in response to Plaintiffs' request for performance. In many jurisdictions the Plaintiff in an anticipatory breach situation is entitled to his damage as of the time for performance (2 above) and not the time of the anticipatory breach, but inasmuch as the market continued to drop and the damages increased after February, the Defendant should not be heard to complain if damages are computed at the lower amount, to-wit:

January	3600 x 2.50	\$ 9,000
or		
February	3600 x 3.00	10,800

There certainly was ample evidence from which the jury could find that the Defendant firmly and finally repudiated any intention to perform the contract in January, or February, and while such a repudiation, coupled with the undisputed evidence that Defendant never ordered any corn under the contract, would have justified a verdict in the sum of \$11,700 or \$12,600, counsel limited Plaintiffs' request to the lower amount to avoid appellate litigation of the issue as to whether or not Plaintiffs, in an anticipatory breach situation, are entitled to damages as of the time of the breach or as of the time of performance. (Inasmuch as Plaintiffs originally commenced their action in April of 1954, this was more of a problem than appears in the record of this trial.)

The jury, as the exclusive trier of the facts, appar-

ently rejected the evidence tending to show a repudiation in January and found that Exhibits 10 and 11 constituted a repudiation and renunciation of the contract.

### **ARGUMENT RE APPELLANT'S POINT IV**

The District Court did not err with respect to testimony respecting prior relations of the parties.

On pages 39 and 40, Appellant directs attention to certain testimony of the Plaintiffs appearing on page 60 of the Record. This same testimony had previously gone into the Record (R. 40) without remonstrance from counsel, was invited by the irrelevant inquiry of counsel in the cross-examination which immediately preceded it (R. 58 and 57), and dealt with matters that counsel deemed relevant, to-wit the past dealings of the parties. See page 31 of Appellant's Brief and pages 62 and 72 of the Record wherein counsel assumed the relevance of the past dealings of the parties.

### **ARGUMENT RE APPELLANT'S POINT V**

The Court did not err in failing to grant Appellant's Motion for Dismissal on the grounds that the contract provided exclusive remedies.

### **Points and Authorities**

Remedies provided in a contract are not exclusive unless so expressed.

Lee v. Blockland, 122 Or 230, 257 P 801,  
 compare with  
 Potter Realty Co. v. Derby, 75 Or 566, 147 P 548.

Plaintiffs do not quarrel with Defendant's contention that parties may by agreement modify or extinguish remedies otherwise provided by law (Br. pp. 41 and 42). Plaintiffs submit, however, that the parties in this instance did not so provide. A comparison of the two cases cited above shows the language under which it is held that a contract provides an exclusive remedy. If the contract herein provided that the Plaintiffs "shall" do such and so (Christian Mills case cited p. 42, App. Br.), Defendant's point would be well taken. If the contract did not expressly provide that Plaintiffs "may" at their "option" do such and so, the Defendants could, perhaps, argue an exclusive remedy by implication (Permutit Co. case cited p. 42, App. Br.), but it would seem that under the wording of this contract there is no question.

Defendant also argues (Br. p. 41) that Plaintiffs' invoicing for the goods proves that seller himself assumed that the remedies were exclusive of the general law of sales. To the contrary, seller concluded that because of his failure to appropriate the goods to the contract as required by the general law of sales (see R. 50 for evidence that the goods were not appropriated to the contract, i.e., there was no segregation of corn which was designated as the buyer's), he could not bring an action for the contract price. This is fortunate for the Defendant inasmuch as Plaintiffs would have been permitted (see *D'Aprile v. Turner-Looker Co.*, 239 N.Y. 427, 38 A.L.R. 1426, and *Urbansky v. Kutinsky*, 84 A. 317, 86

Conn. 22) to sell the buyer's goods for \$4.75 a bag (R. 54) and recover the balance of the purchase price from the Defendant. We submit that it is clear that Defendant's conduct does not amount to a practical construction of the contract to the effect that it provided exclusive remedies.

Defendant also argues (R. 41) that Plaintiffs, by their conduct of invoicing subsequent to the breach, made an irrevocable election of remedies. This as in the case of the argument that Plaintiffs are estopped to assert the Statute of Frauds, is urged now the first time in the case. The pleadings, pre-trial order, objections, motions and requested instructions did not bring these issues before, or to the attention of, the trial court and the trial court made no ruling thereon. It is well settled that such matters cannot now be urged for the first time. *Sorenson v. U. S.*, 226 F.2d 460; *City of Erlanger v. Berkemeyer*, 207 F.2d 832. Moreover, the portion of Am. Jur. quoted in Appellant's Brief (p. 41) is not applicable in view of the evidence (R. 50) that goods were not appropriated to the contract. Hence, the Plaintiffs did not deal with the property in their possession in a manner inconsistent with the remedy pursued herein.

**CONCLUSION**

The Defendant by entering into this "futures contract" stood to gain or lose depending upon the future market price of popcorn. We submit, for the reasons stated herein, that he should be required to take his loss as pronounced by the Judgment of the District Court.

Respectfully submitted,

M. H. CLARK,  
WILLIAM E. TASSOCK,  
Attorneys for Appellees



---

---

**United States**  
**COURT OF APPEALS**  
**for the Ninth Circuit**

---

H. P. WILLMAN, Doing Business as POPPERS  
SUPPLY CO.,

*Appellant,*

vs.

HAROLD M. ALVER, OSCAR J. ALVER,  
RAYMOND N. ALVER, LUCILE M. AL-  
VER, JEANNETTE B. ALVER and MIL-  
DRED M. ALVER, a Co-partnership Doing  
Business as Premier Popcorn Company,

*Appellees.*

---

**APPELLANT'S REPLY BRIEF**

---

*Appeal from Final Judgment of the United States  
District Court for the District of Oregon.*

HON. CLAUDE McCOLLOCH, Judge.

---

RECEIVED

JOHN F. REYNOLDS,  
Equitable Building,  
Portland 4, Oregon,

JUN - 5 1957

J. P. STIRLING,  
3128 N. E. Broadway,  
Portland 12, Oregon,

PAUL P. O'BRIEN  
CLERK

*Attorneys for Appellant.*



**United States**  
**COURT OF APPEALS**  
**for the Ninth Circuit**

---

H. P. WILLMAN, Doing Business as POPPERS  
SUPPLY CO.,

*Appellant,*

vs.

HAROLD M. ALVER, OSCAR J. ALVER,  
RAYMOND N. ALVER, LUCILE M. AL-  
VER, JEANNETTE B. ALVER and MIL-  
DRED M. ALVER, a Co-partnership Doing  
Business as Premier Popcorn Company,

*Appellees.*

---

**APPELLANT'S REPLY BRIEF**

---

*Appeal from Final Judgment of the United States  
District Court for the District of Oregon.*

HON. CLAUDE MCCOLLOCH, Judge.

---

**POINT I**

**REPLY TO APPELLEE'S ANSWER TO FIRST  
ASSIGNMENT OF ERROR**

The principle points relied upon by appellant in As-  
signment of Error No. I are:



## INDEX

	Page
Point I—Directed Verdict in Error .....	1
Point II—No Mitigation or Damages Instructed .....	6
Point III—Improper Damage Findings .....	7
Point IV—Prejudicial Testimony .....	8
Point V—Motion for Dismissal .....	9
Conclusion .....	11

## INDEX OF CASES

Callaghan v. Scandlin, 178 Or 249 .....	2
Craswell v. Biggs, 160 Or 527 .....	2
Cummings v. Arnold, 44 Mass 486 .....	5
Maddaloni Olive Oil Co. v. Aquino, 191 NY App Div 51 .....	5
Krebs Hop Co. v. Livesley, 59 Or 586 .....	6
Teuscher v. Utah-Idaho Flour and Grain Co., 221 P. 1096 .....	8
James River Lumber Co. v. Smith Bros., 116 SE 241 .....	8

## STATUTES

Oregon Revised Statutes, § 75.640(2) .....	7
--	---





**United States**  
**COURT OF APPEALS**  
**for the Ninth Circuit**

---

H. P. WILLMAN, Doing Business as POPPERS  
SUPPLY CO.,

*Appellant,*

vs.

HAROLD M. ALVER, OSCAR J. ALVER,  
RAYMOND N. ALVER, LUCILE M. AL-  
VER, JEANNETTE B. ALVER and MIL-  
DRED M. ALVER, a Co-partnership Doing  
Business as Premier Popcorn Company,

*Appellees.*

---

**APPELLANT'S REPLY BRIEF**

---

*Appeal from Final Judgment of the United States  
District Court for the District of Oregon.*

HON. CLAUDE MCCOLLOCH, Judge.

---

**POINT I**

**REPLY TO APPELLEE'S ANSWER TO FIRST  
ASSIGNMENT OF ERROR**

The principle points relied upon by appellant in As-  
signment of Error No. I are:

(1) That a directed verdict is not appropriate when the appellant-buyer against whom it was directed had submitted substantial evidence of a change or rescission of contract, to-wit, a reduction in price, and

(2) That whether the contract between the parties was reduced in price was a question of fact for the jury despite the Statute of Frauds.

The appellee, in his brief, overlooks these points and falls back solely upon the Statute of Frauds. Two of the Oregon cases cited by the appellee, *Callaghan v. Scandlin*, 178 Or. 449, and *Craswell v. Biggs*, 160 Or 547, have no application either on their facts or their law to this case. In fact, one of the cases, *Craswell v. Biggs*, states at p. 560:

“We are advertent to the rule that under certain conditions certain written instruments may be discharged or even modified by a subsequent parol contract, but the evidence sustaining such subsequent parol contract must be clear, convincing and conclusive and it must be predicated upon a legal and valid consideration.”

The appellee, on page 8 and 9 of his brief, states that the appellant is seeking “to excuse himself from liability, sets up an oral agreement or statement by which the performance for which plaintiff sues was prevented.”

The appellant’s evidence, however, shows that there was either a written modification or rescission, consisting of the letter of October 23 (Ex. 3), as explained by the conversations surrounding it, or an oral modification or rescission, consisting of the parties’ conversations.

The appellee's arguments as to oral modification or rescission has no application to the point of whether or not the letter of October 23 (Ex. 3), together with its surrounding conversations resulted in a modification or rescission of the original contract. Certainly written contracts are modified or rescinded every day in the business world by a letter.

The appellee states that he denies the truth of the appellant's testimony. He did that before the trial ever started, but that does not make the appellant's testimony untrue nor preclude it from being considered by the jury.

The appellee now contends also that he could not reduce his price on the corn because of his commitments to the farmers (Appellee's Brief, p. 12). How then could he agree to sell corn to the appellant at \$8.00, a price less than the original contract price, as he did in his letter of October 23rd (Ex. 3)? Or is the appellee now trying to say that he never could actually reduce the price, and if he did, he only did it to help the appellant, but he wants to take back now what he said in that letter of October 23, because he should not have said it in the first place? That is certainly no answer to the fact that the appellee did actually give the appellant a reduced price. Rather, it is an apparent attempt by the appellee to again bolster his claim that he made at the trial for the first time that the price of \$8.00 did not apply to the contract corn but only to corn over and above the contract. It is again submitted that that position is untenable. These parties had a contract for a considerable

amount of corn and when they talked price, they talked contract price. Had the appellant ordered corn at \$8.00 in November or December, it would have been shipped at that price and applied to the contract. See appellee's cross-examination:

R. 56—

“Q. Isn't it a fact that you were actually prepared to hold up that contract almost indefinitely?

A. If the occasion had arose, I imagine we would have held it longer than that *had Mr. Willman purchased his monthly requirement at the market price.*

Q. You mean at the market price or at the \$8.00 price?

A. At the \$8.00 price.”

Does not that statement alone give rise to a question of fact for the jury to decide as to whether or not the price had been reduced:

The appellant's position with respect to the Statute of Frauds is as follows:

1. That there was either

(A) A modification, partly in writing and partly oral, of the original contract by the plaintiff's letter of October 23rd (Ex. 3), together with the conversations of the parties regarding price reduction, or

(B) That there was a rescission, partly in writing and partly oral, of the original contract by the letter of October 23 (Ex. 3), together with the conversations of the parties regarding price reduction, or



- (C) That there was an oral modification or rescission of the contract by the conversations of the parties, or
- (D) That there was a written modification or rescission of the original contract by the letter of October 23 (Ex. 3).

Under all these possibilities, can a court say, as a matter of law, the plaintiff is entitled to a directed verdict, because the defendant's defense of modification or rescission flies in the face of the Statute of Frauds, or should the court instruct the jury to find the fact answers as to whether there was a modification or rescission, partly oral and partly written, or all oral, or all written, and instruct as to what their findings should be in each instance, when applying the Statute of Frauds to the determined facts?

*Cummings v. Arnold*, 44 Mass. 486 at p. 489:

"The general rule is, that no verbal agreements between the parties to a written contract, made before or at the time of the execution of such contract, are admissible to vary its terms or to affect its construction. All such verbal agreements are considered as varied by and merged in the written contract. *But this rule does not apply to a subsequent oral agreement made on a new and valuable consideration, before the breach of the contract. Such a subsequent oral agreement may enlarge the time of performance, or may vary any other terms of the contract, or may waive and discharge it altogether.*"

*Maddaloni Olive Oil Co. v. Aquino*, 191 N.Y. App. Div. 51, at p. 53:

“the change in the contract was as to the date of delivery. The Court below held that that amounted to a rescission of the original contract and substituted a new one therefor. *The House of Lords upon appeal held that it could not be held as a matter of law, that that amounted to a rescission to the original contract but that it was, at least, a question of fact for the jury as to whether the intention of the parties was to rescind the original contract.*”

## POINT II

### REPLY TO APPELLEE'S ANSWER TO SECOND ASSIGNMENT OF ERROR

(A) As previously set forth in detail in appellant's brief, there was substantial evidence of a decrease in price from \$9.00 a bag to \$8.00 a bag, and it is agreed that the appellant buyer ordered all the corn at \$8.00 a bag. But the appellee-seller ignored the order. The appellee-seller could have shipped at \$8.00, and still had a right to claim the \$1.00 over that amount by notifying the buyer he was so doing.

See the following cases cited in appellant's brief:

46 Am Jur, Sales, Section 791 at p. 919.

Arkansas & T Grain Co. v. Young, 96 S.W. 142 (Ark.).

C. T. Gray & Sons v. Satuloff Bros., 105 So. 666 (Ala.).

The cases cited by the appellee, Krebs Hop Co. v. Livesley, 59 Or. 586, is not the factual situation in the case at bar. In the Krebs case, there was no evidence of any reduction in price. In that case the buyer merely offered to pay some price in between the contract price

and the lower market price. He had no basis for doing so.

Can it be said, therefore, that the appellee's damage, if any, is any more than \$1.00 per bag, when the Sales Act states that "the measure of damages is the estimated loss directly and naturally resulting, in the ordinary course of events, from the buyer's breach of the contract." Oregon Revised Statutes 75.640 (2)?

(B) Is the appellant-buyer to be held liable in damages for the October, November and December cars of corn which the appellee-seller was willing to sell for \$8.00 a bag, and the appellant-buyer willing to buy at \$8.00 a bag? (Please see again appellee's testimony as to this, supra, R. 56.)

### **POINT III**

#### **REPLY TO APPELLEE'S ANSWER TO THIRD ASSIGNMENT OF ERROR**

1. There was, at least, a written, not oral, modification of the contract by the "abeyance" letter of October 23rd, but the Court held, by virtue of its direction of verdict and instruction as to time of breach, that the "abeyance" letter mean nothing, in practical effect. If the abeyance letter was of no effect, then the damages should be based upon the original contract shipping dates, as set forth in appellant's brief.

2. In any event, the damages can not be based upon February as the date of breach. In January, the appellant-buyer told the appellee-seller that he would pay no

more than \$8.00, and the appellant-seller said he wanted \$9.00. The seller can not prolong the date of breach to his market advantage.

Both of the cases cited by appellee, *Teuscher v. Utah-Idaho Flour & Grain Co.*, 221 P. 1096, and *James River Lumber Co. v. Smith Bros.*, 116 S.E. 241, on this point are authority, for damages being assessed as of January, or even an earlier date.

The appellee concedes in his brief that the appellant "finally repudiated any intention to perform the contract in January" (Appellant's brief, p. 18).

#### **POINT IV**

#### **REPLY TO APPELLEE'S ANSWER TO FOURTH ASSIGNMENT OF ERROR**

No further comment appears necessary regarding this point, except that the testimony was prejudicial (R. 60) and was not the same testimony as given previously (R. 40) as appellee contends, and if, by any chance, there was any relationship between the testimony given by the appellee in those two instances, the second statement (R. 60) was then "rubbing it in," so to speak, completely irrelevant and extremely prejudicial.

## POINT V

### REPLY TO APPELLEE'S ANSWER TO FIFTH ASSIGNMENT OF ERROR

Appellee's brief seems to concede that appellant's motion to dismiss should have been allowed if the appellee-seller's remedies provided in the contract were exclusive but argues that the seller had other remedies than those set forth in the contract.

The parties chose to set forth in the contract the rights of the seller in event of default by the buyer. Then they continued by saying that the contract covered the entire agreement of the parties. The seller now tries to disregard this latter provision, and seeks to interpret the contract so that he will not only have the three options, but others. The two sections must be read together, and can only be interpreted to mean that the parties agreed that the seller, upon default of the buyer, could do one of three things, and nothing else.

Appellant is not raising this point for the first time on appeal, as claimed in the brief of the appellee, hence the cases on this question are not in point. The fact that three cars were involved showed that seller considered that he should proceed under one of the options that the parties agreed seller should have. The reference to American Jurisprudence in appellant's brief was only to show that what the seller did as to part would apply to the whole. It is not a question of election of remedies, but rather, whether appellee has any right whatever to pursue the remedy which he now does.



Appellee says on page 20 of his brief that "the appellant could, perhaps, argue an exclusive remedy by implication" under the Permutit Co. case. The fact that certain remedies were set forth in the contract, even though not specifically made exclusive, is alone sufficient reason for allowing the motion to dismiss, under the holding of the Permutit Co. case. But the parties here went even further, by providing that the contract expressed the entire agreement. Therefore, either by implication or express agreement, seller was limited to the remedies provided in the contract.

The Oregon cases cited by appellee certainly do nothing more than fortify the position of appellant.

Had the seller desired other remedies in event of buyer's default, he could easily have provided them. But he printed his form so as to have certain specified rights, then provided that his contract contained the entire agreement. He now asks this Court to add what he chose to omit.

The fact that seller chose to so act as not to be in a position to avail himself of his rights under the contract (Appellees' brief, p. 20) is not the responsibility of the buyer, nor of this Court, and the motion to dismiss should have been allowed.

## CONCLUSION

For the reasons stated in appellant's brief, and as reiterated herein, it is submitted that the judgment of the District Court should be reversed.

Respectfully submitted,

JOHN F. REYNOLDS,  
Equitable Building,  
Portland, Oregon,

J. P. STIRLING,  
3128 N. E. Broadway,  
Portland, Oregon,

Attorneys for Appellant.



No. 15430

---

---

United States  
Court of Appeals  
For the Ninth Circuit

---

SAM BLASSINGAME,

Appellant,

vs.

UNITED STATES OF AMERICA,

Appellee.

---

Transcript of Record

---

Appeal from the United States District Court for the  
Western District of Washington,  
Northern Division.

FILED

OCT 15 1957

PAUL P. O'BRIEN, CLERK

---

---





No. 15430

---

United States  
Court of Appeals  
For the Ninth Circuit

SAM BLASSINGAME,

Appellant,

vs.

UNITED STATES OF AMERICA,

Appellee.

Transcript of Record

Appeal from the United States District Court for the  
Western District of Washington,  
Northern Division.



## INDEX

---

[Clerk's Note: When deemed likely to be of an important nature, errors or doubtful matters appearing in the original certified record are printed literally in italic; and, likewise, cancelled matter appearing in the original certified record is printed and cancelled herein accordingly. When possible, an omission from the text is indicated by printing in italic the two words between which the omission seems to occur.]

	PAGE
Certificate of Clerk.....	208
Designation of Record on Appeal, Amended..	211
Indictment .....	3
Judgment and Sentence.....	7
Motion in Arrest of Judgment.....	6
Names and Addresses of Attorneys.....	1
Notice of Appeal.....	9
Statement of Points.....	210
Verdict .....	5
Testimony of Witnesses.....	10
Blassingame, Sam	
—direct .....	178
—cross .....	181
—redirect .....	189
Clairborne, Allen	
—direct .....	190, 195
—cross .....	201
Clark, Johnny	
—direct .....	90

## Testimony of Witnesses—(Continued):

Du Puis, Charles F.

—direct .....	120
—cross .....	125

Fahey, Charles

—direct .....	64, 168
—cross .....	79, 172
—redirect .....	86

Gooder, Lavern E.

—direct .....	50, 166
—cross .....	56

Henaby, William E.

—direct .....	156
---------------	-----

Kirschner, C. F.

—direct .....	129, 139, 194
—cross .....	151
—redirect .....	156

Sprinkle, Chester G.

—direct .....	11
—cross .....	23
—redirect .....	46

Waite, Robert W.

—direct .....	161
---------------	-----

## NAMES AND ADDRESSES OF ATTORNEYS

CORNELIUS CHAVELLE,

1401 Dexter Horton Bldg.,

Seattle 4, Washington;

MAX KOSHER,

JOHN N. LEAVITT,

619 Second Ave.,

Seattle 4, Washington,

Attorneys for Appellant.

CHARLES P. MORIARTY,

United States Attorney;

JOHN ROBERTS, JR.,

Assistant United States Attorney,

1012 U. S. Courthouse,

Seattle 4, Washington,

Attorneys for Appellee.





United States District Court, Western District of  
Washington, Northern Division  
No. 49488

UNITED STATES OF AMERICA,

Plaintiff,

vs.

SAM BLASSINGAME,

Defendant.

INDICTMENT

The Grand Jury charges:

Count I.

That on or about May 29, 1956, at Seattle, within the Northern Division of the Western District of Washington, Sam Blassingame did knowingly, wilfully and unlawfully receive and conceal a quantity of narcotic drugs, to wit, thirty-six (36) grains of heroin hydrochloride, knowing the said heroin hydrochloride to have been imported contrary to law.

All in violation of Section 174, Title 21. U.S.C.

Count II.

That on or about May 29, 1956, at Seattle, within the Northern Division of the Western District of Washington, Sam Blassingame did knowingly, wilfully and unlawfully sell and give away a quantity of narcotic drugs, to wit, thirty-six (36) grains of heroin hydrochloride, not in pursuance of a written order of the person to whom such heroin hydro-

chloride was sold and given away on a form issued in blank for that purpose by the Secretary of the Treasury.

All in violation of Section 4705(a), Title 26, U.S.C.

### Count III.

That on or about June 19, 1956, at Seattle, within the Northern Division of the Western District of Washington, Sam Blassingame did knowingly, wilfully and unlawfully receive and conceal a quantity of narcotic drugs, to wit, five hundred two (502) grains of heroin hydrochloride, knowing the said heroin hydrochloride to have been imported contrary to law.

All in violation of Section 174, Title 21, U.S.C.

### Count IV.

That on or about June 19, 1956, at Seattle, within the Northern Division of the Western District of Washington, Sam Blassingame did knowingly, wilfully and unlawfully dispense and distribute a quantity of narcotic drugs, to wit, five hundred two (502) grains of heroin hydrochloride, said heroin hydrochloride being neither in nor from the original stamped package and not bearing appropriate tax paid revenue stamps.

All in violation of Section 4704(a), Title 26, U.S.C.

A True Bill.

/s/ JOHN STEEN,  
Foreman.

/s/ CHARLES P. MORIARTY,  
United States Attorney;

/s/ JOHN A. ROBERTS, JR.,  
Assistant United States  
Attorney.

Bail: \$10,000.

Presented and filed Sept. 12, 1956.

————

[Title of District Court and Cause.]

### VERDICT

We, the Jury in the Above-Entitled Cause, Find the Defendant, Samuel Blassingame not guilty as charged in Count I of the Indictment; and further find the Defendant, Samuel Blassingame, not guilty as charged in Count II of the Indictment; and further find the Defendant, Samuel Blassingame is guilty as charged in Count III of the Indictment; and further find the Defendant, Samuel Blassingame, is guilty as charged in Count IV of the Indictment.

Dated: January 16, 1957.

/s/ PAUL TYCHSEN,  
Foreman.

[Endorsed]: Filed Jan. 16, 1957.

[Title of District Court and Cause.]

MOTION FOR ACQUITTAL N O V IN ARREST  
OF JUDGMENT OR IN THE ALTERNA-  
TIVE MOTION FOR A NEW TRIAL

Comes Now the defendant, Sam Blassingame, and moves the court for an order of acquittal N O V in arrest of judgment or in the alternative for a new trial.

The motion for acquittal N O V in arrest of judgment is based upon the insufficiency of the evidence to justify the submission of Counts III and IV of the indictment to the jury for their consideration, and in the event that the motion for acquittal N O V in arrest of judgment is denied, the defendant above named moves for a new trial upon the following grounds:

1. That the verdict is contrary to the interest of justice.
2. For error occurring at the time of the trial and excepted to by the defendant.
3. That the verdict is contrary to law.

/s/ CORNELIUS C. CHAVELLE,  
Attorney for Defendant,  
Sam Blassingame.

[Endorsed]: Filed Jan. 18, 1957.

United States District Court for the Western  
District of Washington, Northern Division

No. 49488

UNITED STATES OF AMERICA,

vs.

SAM BLASSINGAME.

### JUDGMENT AND COMMITMENT

On this 28th day of January, 1957, came the attorney for the government and the defendant appeared in person and with his attorney, Cornelius C. Chavelle.

It Is Adjudged that the defendant has been convicted upon a jury verdict of the offense of violation of Section 174, Title 21, U.S.C., and Section 4704 (a), Title 26, U.S.C., as charged in Counts III and IV of the Indictment and the court having asked the defendant whether he has anything to say why judgment should not be pronounced, and no sufficient cause to the contrary being shown or appearing to the Court,

It Is Adjudged that the defendant is guilty as charged and convicted.

It Is Adjudged that the defendant is hereby committed to the custody of the Attorney General or his authorized representative for imprisonment for a period of Five (5) Years in the U. S. Penitentiary at McNeil Island, Washington, or such other

like institution as the Attorney General of the United States or his authorized representative may by law designate, and shall pay a fine of \$2,000.00 and shall stand committed until said fine is paid, on Count III of the Indictment.

It Is Further Adjudged that the defendant is hereby committed to the custody of the Attorney General or his authorized representative for imprisonment for a period of Five (5) Years in the U. S. Penitentiary at McNeil Island, Washington, or such other like institution as the Attorney General of the United States or his authorized representative may by law designate, and shall pay a fine of \$2,000.00 and shall stand committed until said fine is paid, on Count IV of the Indictment. The execution of the sentence imposed on Count IV shall be consecutive to, and not concurrent with, the execution of the sentence imposed on Count III.

It Is Ordered that the Clerk deliver a certified copy of this judgment and commitment to the United States Marshal or other qualified officer and that the copy serve as the commitment of the defendant.

Done in Open Court this 28th day of January, 1957.

/s/ WILLIAM J. LINDBERG,  
United States District Judge.

Presented and approved by:

/s/ JOHN A. ROBERTS, JR.,  
Asst. U. S. Attorney.

[Endorsed]: Filed Jan. 28, 1957.



[Title of District Court and Cause.]

NOTICE OF APPEAL

Name and Address of Appellant: Sam Blassingame, 2921 Yesler Way, Seattle, Washington.

Name and Address of Appellant's Attorney: Cornelius C. Chavelle, 1401-04 Dexter Horton Building, Seattle, Washington.

Offense: Violation of Section 174, Title 21, U.S.C. (1 Count); Violation of Section 4704(a), Title 26, U.S.C. (1 Count).

Sentenced: January 28th, 1957.

I, the above-named appellant, hereby appeal to the United States Circuit Court of Appeals for the Ninth Circuit from the above-stated Judgment.

Dated this 28th day of January, 1957.

/s/ CORNELIUS C. CHAVELLE,  
Appellant's Attorney.

Receipt of copy acknowledged.

[Endorsed]: Filed Jan. 29, 1957.

In the District Court of the United States for the  
Western District of Washington, Northern Di-  
vision

No. 49488

UNITED STATES OF AMERICA,

Plaintiff,

vs.

SAM BLASSINGAME,

Defendant.

TRANSCRIPT OF PROCEEDINGS

William J. Lindberg, United States District Judge.

Appearances:

JOHN A. ROBERTS, JR.,

Assistant United States Attorney,

Appeared for and on behalf of the  
Plaintiff; and

CORNELIUS C. CHAVELLE,

MAX KOSHER,

Appeared for and on Behalf of the De-  
fendant. [2\*]

January 15, 1957—10:00 A.M.

CHESTER G. SPRINKLE

upon being called as a witness for and on behalf of  
the plaintiff, and upon being first duly sworn, testi-  
fied as follows:

The Clerk: State your full name and spell your  
last name, please.

(Testimony of Chester G. Sprinkle.)

The Witness: Chester G. Sprinkle, S-p-r-i-n-k-l-e  
(spelling).

Direct Examination

By Mr. Roberts:

Q. Where do you reside, Mr. Sprinkle?

A. 154 West 59th, Seattle, Washington.

Q. And what is your occupation?

A. Narcotic officer for the Seattle Police Department.

Q. How long have you been with the Seattle Police Department?

A. Oh, approximately 10 years.

Q. And prior to that time have you had any other police training or work?

A. I was a Federal Narcotic Agent for two and one-half years during this interim.

Q. Now, Mr. Sprinkle, were you so employed during the month of May in the year 1956?

A. Yes, sir. [24]

Q. Inviting your attention to on or about May 29th of 1956, I will ask you if you had occasion to meet one Johnny Clark on or about that date?

A. Yes, sir; I did.

Q. Will you describe the circumstances surrounding that meeting?

A. Detective Waitt and myself met Johnny Clark approximately 9:00 o'clock at a prearranged meeting place.

Q. And where was that?

A. That was at the train depot on Jackson Street—the Great Northern train depot.

(Testimony of Chester G. Sprinkle.)

Q. What did you do after meeting him?

A. I drove Johnny up to a parking lot at 7th and Madison, and met the Federal agents up there—Agents Fahey, DuPuis, and Mr. Gooder.

Q. Now, I am referring to May 29, 1956.

Did you at any time that evening go to the corner of 19th and Roy?      A. Yes, sir.

Q. Pardon me—I am getting ahead of your story. What did you do?

A. Right after that, we proceeded to 19th and East Roy, and I went into a phone booth with Johnny Clark, and I observed him——

Q. (Interposing): Well, now, describe the phone booth. [25] Was it in a building?

A. No; it was a little independent phone booth on the northeast corner of 19th and Roy.

Q. I will ask you to describe Johnny Clark.

A. Johnny Clark is a colored man, and he is approximately 27 years old, and about five feet nine inches, maybe 145 pounds.

Q. And with relation to narcotics and the use thereof, what is your knowledge of Johnny Clark?

Mr. Chavelle: I will object to that, your Honor, as not material or relevant. There is no proper foundation.

The Court: Will you read that, please, Mr. Reporter?

(Whereupon, the following was read by the reporter: “Question: And with relation to narcotics and the use thereof, what is your knowledge of Johnny Clark?”)

(Testimony of Chester G. Sprinkle.)

Mr. Roberts: I submit, your Honor, my question may be in bad form, but I believe that the subject matter is pertinent.

Mr. Chavelle: I don't think the subject matter is pertinent, and I don't think it is correct form.

The Court: I will sustain the objection. [26]

Q. (By Mr. Roberts, continuing): In connection with your work as a Narcotics Officer for the Seattle Police Department, what dealings, if any, have you had with Johnny Clark?

Mr. Chavelle: I will object to that as not relevant in this case at all. I object to the form of the question.

The Court: It seems to be immaterial at this time. I will sustain the objection. It could be at a later date.

Mr. Roberts: Yes; very well.

Q. (By Mr. Roberts, continuing): On arriving at the corner of 19th and Roy, what did you do?

A. Johnny Clark and I went into this phone booth that I mentioned, and I observed Johnny going through a notebook, and pick out a phone number with the name "Sam" behind it.

I am not sure of the phone number at this time.

Then he put a dime in, and dialed this number, and I monitored the phone with Johnny.

Q. What do you mean when you say, "monitored the phone"?

A. He held the phone up to my ear so that we could both hear what was said. I heard a man [27] answer.

Johnny asked him if it was all right to come by.



(Testimony of Chester G. Sprinkle.)

Mr. Chavelle: I will object to that, your Honor, to any conversation. It must first be established that this man is familiar with the person on the other end of the phone, and knows—the proper foundation must be laid—and knows who Johnny Clark was talking to, if anyone, and who it was; and that he is, firstly, familiar with the man's voice, and I object, before any conversation can be elicited by this witness to any Johnny Clark is supposed to have had.

Mr. Roberts: I certainly agree with counsel, your Honor, and I feel that conversation heard would be hearsay and inadmissible; so whether or not you—

Mr. Chavelle (Interposing): I will ask the last answer be stricken.

The Court: The answer with respect to what was stated over the telephone, as the witness testified, may be stricken, and the jury will disregard that portion of the testimony.

Q. (By Mr. Roberts): After the call was placed, Mr. Sprinkle, state whether or not you were familiar with the voice at the other end of the phone call.      A. Yes, sir; I believe I was.

Q. Whose voice was it? [28]

A. I believed it to be Mr. Blassingame.

Mr. Chavelle: I will object to that, your Honor, and ask that I examine Mr. Sprinkle before he goes into this conversation.

He said he believed it was Mr. Blassingame. I



(Testimony of Chester G. Sprinkle.)

believe we should have an opportunity to examine his past experience.

The Court: On voir dire, you may. Go ahead. Do you want to ask him?

Mr. Chavelle: Yes.

The Court: Go ahead.

Mr. Chavelle: Now, Mr. Sprinkle, have you had previous conversations prior to the 29th day of May, 1956, with Mr. Blassingame on the telephone?

The Witness: No, sir; I have not.

Mr. Chavelle: You never had a conversation with him on the telephone?

The Witness: No, sir.

Mr. Chavelle: So, you would not recognize his voice, any more than you would recognize mine, because of no previous experience in talking to him on the telephone, isn't that correct?

The Witness: No, sir; I wouldn't say that is correct.

Mr. Chavelle: Well, you say you believe it [29] was his voice, but you have had no experience prior to determine his voice, is that right?

The Witness: On the telephone; I have never talked to him on the telephone. I have talked to him before on the street.

Mr. Chavelle: People do talk and sound differently on the telephone than they do personally; is that correct?

The Witness: That is right.

Mr. Chavelle: Can you testify positively you

(Testimony of Chester G. Sprinkle.)

could recognize Sam Blassingame's voice on the telephone? Is that right?

The Witness: I wouldn't positively say so; no, sir.

Mr. Chavelle: I don't think that that is sufficient. I don't think there is proper foundation laid here.

The Court: He stated he has heard him talk, and he said he believed he was. It seems to me it is a matter of weight for the jury, and the Court will overrule the objection.

Q. (By Mr. Roberts): Now, then, what was——

Mr. Chavelle (Interposing): Just for the record, I will renew my objection, or state my objection for [30] the record, your Honor.

The Court: You may.

Mr. Chavelle: This would be violation of the hearsay rule, and no proper foundation has been laid for this witness to become either an expert witness or to form an opinion as to whether or not this was Mr. Blassingame's voice on the ground he never talked to him on the phone before, and he merely states now he believes it was his voice; and there is no foundation for that position.

The Court: The record may show your objection, Mr. Chavelle.

Mr. Chavelle: Thank you.

Q. (By Mr. Roberts, continuing): Now, Mr. Sprinkle, will you state the substance of the conversation?

Mr. Chavelle: My objection goes to all this conversation.

(Testimony of Chester G. Sprinkle.)

A. He asked if it was Sam, and the voice on the other end of the line said, "Yes."

As near as I can recall it, he said, "Is it all right if I come by?"

And the man on the other end of the line said, "Yes," and that is about the substance of it. It was very concise and brief. [31]

Q. (By Mr. Roberts): And you heard the voice on the other end of the line at that time?

A. Yes, sir.

Q. After that telephone call, what did you do then?

A. We put Johnny Clark in one of the Government cars, and Detective Waitt and myself and Federal Agent Gooder accompanied him down to the corner of 22nd and East Thomas.

During this time we could observe Mr. Gooder searching Clark in the back of the car, and he gave him some type of money.

At the corner of 22nd and Thomas, Gooder, who was driving, pulled just south of Thomas on 22nd, and parked the car and turned the lights out.

I got out of the car with Mr. Clark, and I walked beside him north on 22nd to approximately the corner of Thomas Street, or there is a lot there. We cut through the lot, and I dropped off towards the far end of the lot, and I observed Johnny Clark walk down to the driveway that leads into the house on 22nd and East Thomas.

I saw him go to the back door and knock. In a

(Testimony of Chester G. Sprinkle.)

few moments the door opened, and Mr. Blassingame let Johnny in.

Q. Now, I might interrupt you there. You say that Mr. Blassingame let Johnny in? [32]

A. Yes, sir.

Q. Do I understand—what were—state whether or not you observed any individual in the door at that time?

A. I observed Mr. Blassingame in the doorway.

Q. The man you observed in the doorway, is he present in the courtroom? A. Yes, sir.

Q. Will you indicate his position in the courtroom? A. The man next to Mr. Chavelle.

Mr. Roberts: May the record show the witness identified Mr. Blassingame?

The Court: The record speaks for itself.

Mr. Roberts: Yes, sir.

Q. (By Mr. Roberts): Now, then, what happened?

A. It was about five minutes later—possibly ten—we observed, or I observed about a 1954 or 1955, red and white Oldsmobile drive up, and a woman I believe to be Bernice Fitzgerald, jumped out of the car and ran in the same back door Mr. Clark had gone in.

She wasn't in there over two minutes, and she returned and got in the car and drove away.

Now, not over two or possibly three minutes later a light came on the back porch, and it looked like an Oriental, I believe a Japanese man, came out on the back [33] porch.

(Testimony of Chester G. Sprinkle.)

Q. Was the light on the door you observed Clark go in?

A. It was just to the right of the doorway coming out, and it was possibly five feet above the doorway.

Q. And then what happened?

A. The light came on, and this Oriental came out and either mopped or swept the porch off.

Q. Did he come out the back door Clark entered?

A. No, sir; the other side of the duplex.

Q. And then what happened?

A. He went back in, and maybe two or three minutes later I observed the door open and Mr. Blassingame, in a white shirt, stuck his head out and looked both directions and stepped back in, and Mr. Clark came out.

Johnny walked past the foot path and past the vacant lot, and I waited until I couldn't be seen from the doorway, and I walked beside Johnny back to the Government car.

He got in the back seat and handed Agent Gooder a package, which Waitt and myself and Clark and Gooder initialed at the time.

Q. I will ask that you examine the envelope marked Plaintiff's Exhibit No. 1, examine the contents of that envelope, and state what it is, if you know? [34]

A. This is the same bindle that Johnny Clark handed to Mr. Gooder in the back of the car.

Q. How are you able to make that statement?



(Testimony of Chester G. Sprinkle.)

A. The date and the time is on it. I saw Mr. Gooder place that on there, and I placed my initials, "C.G.S.," on here.

Q. Do your initials appear thereon?

A. Yes, sir.

Q. Do other initials appear thereon?

A. Yes; they do.

Q. Did you observe anybody else place their initials on the bundle?

A. Detective Waitt, Agent Gooder, and also Mr. Clark.

Q. Very well. You can return that to the envelope.

Now, then, inviting your attention to the date on or about June 19, 1956, state whether or not you met Johnny Clark at or about that time?

A. Yes, sir. It was approximately 9:00 o'clock again on the evening at the same train depot.

Q. What did you do? Who was with you?

A. Detective Kirschner and Detective Bill Henaby, and two narcotic officers.

Q. Of the Seattle Police Department?

A. Yes, sir.

Q. After meeting Clark, what did you do? [35]

A. We had made prearranged plans to meet the Federal officers at 7th and James, and we drove up there.

Q. Did you meet with anyone?

A. Yes, sir; we met Mr. Fahey and Mr. Gooder, and Agent Du Puis, and the U. S. Marshal, Jim Clark, was there, and also I believe the narcotic clerk, Lee Hope, was there.



(Testimony of Chester G. Sprinkle.)

Q. Now, then, what did you do?

A. We talked to Johnny a few moments.

Q. I don't wish you to relate the conversation. What happened as a result of this meeting?

A. We talked to Johnny a few moments and had Johnny in the back of the car with us, and we stayed with him while some of the other officers left in one of the cars.

Q. Did they return?

A. They returned in approximately twenty-five or thirty minutes; maybe longer.

Q. What happened upon their return?

A. We all proceeded down to our Narcotics Office at the Seattle Police Department, and we attempted to lift some fingerprints off of a package of white powder.

Q. You observed a package of white powder?

A. Yes, sir; I did.

Q. Will you examine Plaintiff's Exhibit No. 2, and state what it is? I am referring to the contents of that [36] envelope.

A. This is the same rubber container that we attempted to get fingerprints off of down there, and we also marked our initials on it.

Q. Tell the jury how you are able to recognize and make the definite statement?

A. The date and time is also on this one, and my initials, and theirs, are all on it. That is the way we mark all the evidence.

Q. You, yourself, marked this for what purpose?

A. For future identification in court.

(Testimony of Chester G. Sprinkle.)

Q. All right; and what happened to this particular rubber container, if you know, after you marked it?

A. It was in the custody of one of the Federal agents; I believe Mr. Fahey had custody of it.

Mr. Roberts: I have no further questions.

The Court: I think we might take a recess now.

Mr. Chavelle: Fine, your Honor.

The Court: Members of the Jury:

We will now take the midmorning recess. It is a little bit late this morning, but I did not notice the time.

In the course of this case, while serving as jurors, be cautious on any occasion and be careful you [37] don't discuss this case with your fellow jurors or anyone else on the outside, and be careful you do not formulate or reach any conclusions regarding the issues in this case until you have heard all the evidence, and the instructions of the Court, and the case is finally submitted to you for your verdict.

Bear in mind that the plaintiff puts in their testimony first, and it is necessary to have all the evidence and the law with respect to it before you reach your conclusions, and you do that at the time of your final deliberation when the case is completed.

You may now be excused. Bear this admonition in mind whether I repeat it or not on the occasion of every recess.

(Whereupon, the jury retired from the courtroom.)

(Testimony of Chester G. Sprinkle.)

The Court: Just a moment, please.

For information of counsel, when the jury goes out, it is my practice for the parties and counsel and the Court to remain, and we recess afterwards.

Mr. Chavelle: All right, your Honor.

The Court: The Court will take a ten-minute recess.

(Whereupon, at 11:19 o'clock a.m., a recess was had in the within-entitled and numbered cause, [38] until 11:32 o'clock a.m., January 15, 1957, at which time counsel and the defendant, heretofore noted being present, the following proceedings were had, to wit.)

The Court: You may call the jury.

(Whereupon, the jury was returned to the courtroom.)

The Court: You may be seated.

It is stipulated that the jury and the defendant are present in the courtroom?

Mr. Chavelle: Yes, your Honor.

Mr. Roberts: It is so stipulated, your Honor.

The Court: You may proceed.

Mr. Roberts: I have concluded my interrogation, your Honor.

Mr. Chavelle: All right.

### Cross-Examination

By Mr. Chavelle:

Q. Mr. Sprinkle, approximately what time was it when you arrived at the intersection of 19th and

(Testimony of Chester G. Sprinkle.)

East Roy, near the Roycroft Theatre, on the 29th day of May, 1956?

A. Approximately twenty minutes to ten.

Q. And would you describe this phone booth in more particular? [39]

A. As I remember it, it is a little independent phone booth, one of the small ones that stand all by itself. It is right next to a little delicatessen or ice creamery on the northeast corner of 19th and Roy.

Q. A closed phone booth?           A. Yes, sir.

Q. With a pay phone in it?           A. Yes.

Q. And large enough for two people to get in there?

A. We had to squeeze in there and shut the door.

Q. Now, you stated on direct examination that in your belief it was Mr. Blassingame on the other end of the telephone, is that correct?

A. That is correct.

Q. I will ask you again if you have ever had any telephone conversation with Mr. Blassingame?

A. No, sir.

Q. I will ask you what led you to believe it was Mr. Blassingame's voice, when you state you had no previous experience in talking over the phone with him?

A. I have known Sam for a long time, and I have talked with him a few times and listened to him talk several times on the street and other places. Sam has a peculiar voice and peculiar drawl, and

(Testimony of Chester G. Sprinkle.)

I was pretty positive it was Sam Blassingame's voice. [40]

Q. Haven't most colored people got a drawl?

A. Yes, they have.

Q. It is possible, is it not, it could have been somebody other than Sam Blassingame on the other end of the phone?

A. It is possible.

Q. Prior to the 29th day of May, 1956, when was the last time you had any conversation with Mr. Blassingame, other than over the phone?

A. It was quite some time.

Q. Would it be a year?

A. Possibly a year.

Q. Possibly a year since you last talked to him, which would be a year prior to this telephone conversation, is that correct?

A. Pretty close.

Q. So that you are unable to state with firm positiveness that it was Sam Blassingame on the other end of the phone?

A. How do you say that?

Q. I say, you are unable to state with firm positiveness that it was Sam Blassingame on the other end of the phone?

A. No, sir.

Q. What [41]

A. No, sir.

Q. You are unable to state that?

A. That is correct; yes, sir.

Q. With whom did this person by the name of Johnny Clark ride to his next destination?

A. At what time?

Q. With whom did this person referred to as Johnny Clark ride with then to the next destination?

A. You mean from 19th and Roy?



(Testimony of Chester G. Sprinkle.)

Q. Yes.

A. Agent Sam Gooder, myself, and Detective R. W. Waitt.

Q. What was the next destination?

A. It was approximately 20th and Roy, I believe, where we stopped the car for a moment to search Johnny Clark.

Q. Who searched Johnny Clark?

A. Agent Gooder.

Q. Where were you at the time the search was going on there?      A. I was in the front seat.

Q. Where was Johnny Clark being searched; where was he located?      A. In the back seat.

Q. Did you pay any attention to the search?

A. Yes, sir. [42]

Q. Did you observe the entire search?

A. Just about.

Q. What do you mean by "just about"?

A. Well, I observed Mr. Gooder going through his pockets, and feeling up and down his pants legs, and coat, and all of his pockets, and checking his wallet, and anything in his pockets, and I observed him give him what I believe to be Government advance funds at the time.

Q. Pardon?

A. And I saw him give Mr. Clark what I believe to be Government advance funds.

Q. I didn't ask you that. I asked about the search.

Was the inner clothing of Mr. Clark examined?



(Testimony of Chester G. Sprinkle.)

A. I couldn't tell you to what extent Agent Gooder examined him.

Q. I didn't ask you that. Was the inner clothing examined?      A. I don't know.

Q. Were the shoes examined?

A. I don't know that.

Q. Was the body itself examined?

A. I don't believe it was.

Q. Were shoes removed?

A. I don't remember.

Q. Well, you must remember whether or not the shoes [43] were removed, if you observed the search.

A. I don't remember whether his shoes were removed or not, or whether Mr. Gooder felt in them, or how he handled it.

Q. Was his pants leg pulled up, and his legs examined; his garters or socks?

A. I don't believe they were pulled up; no, sir.

Q. In other words, the type of search you were talking about was through his pockets?

A. I didn't observe the whole search.

Q. I thought you said a few moments ago you observed the whole search?      A. No, sir.

Q. What part didn't you observe?

A. Well, I was busy with a couple of other details, trying to tell Johnny what to do, and I observed most of the search.

Q. What part of the search did you not observe?

A. Well, that is pretty hard to pin that down.

Q. Were you in the car all the time?

(Testimony of Chester G. Sprinkle.)

A. Yes.

Q. Or did you leave the car?

A. No, sir; I was in the car all the time.

Q. But you were not paying attention to the search in the entirety, is that correct? [44]

A. Not in the entirety.

Q. So that there are various items you don't know about, such as the shoes and the legs and the body search, and the underclothing, and so on; is that correct? A. That is right.

Q. And you had nothing to do with the search itself? A. No, sir.

Q. Just as an impartial observer; is that correct? A. That is correct.

Q. Did you search Johnny Clark after you and Clark left the car before he entered these premises?

A. No; I did not.

Q. Then you wouldn't be able to tell this jury whether or not, before Mr. Clark entered that house, or during the time he entered the house—prior to the time he entered the house—whether he had any narcotics on his person, would you?

A. Would you restate that, please?

Q. It is a long question.

The Court: Do you want the reporter to read it? The reporter will read the question, please.

(Whereupon, the following was read by the reporter: "Question: Then you wouldn't be able to tell this jury whether or not, before Mr. Clark entered [45] that house, or during the

(Testimony of Chester G. Sprinkle.)

time he entered the house—prior to the time he entered the house—whether he had any narcotics on his person, would you?’’)

A. I believed him to be clean of narcotics.

Q. (By Mr. Chavelle): How did you reach that conclusion when you didn't have anything to do with the search?

A. I witnessed most of the search, and I took it for granted that the agent that was completing the search did a thorough job. We were working on another detail.

Q. You take it for granted he did a thorough job, and you don't know whether the shoes were searched or the body was searched or the under-clothing was searched; is that correct?

A. Do you mean checking his bare body?

Q. Taking off his shirt?           A. No, sir.

Q. You say you just take it for granted he was clean of narcotics?           A. Yes, sir.

Q. By the partial observation you made of the search; is that correct?           A. Yes, sir.

Q. It is still possible, at least, from your testimony, that he might have had some narcotics on his person, [46] is that correct?

A. It is possible.

Q. Now, you have made some mention about Government funds. To what are you referring?

A. To what am I referring?

Q. Yes.

A. Invariably in these cases one of the Government agents will——

(Testimony of Chester G. Sprinkle.)

Q. (Interposing): I am asking you about this case. Confine yourself to this case itself. What are you referring to as Government funds?

A. It would be money to purchase narcotics, of which the serial numbers would be recorded, or were recorded.

Q. Were Government funds given to Mr. Clark?

A. Yes, sir.

Q. Where? A. In the back of the car.

Q. Did you observe that? A. Pardon me?

Q. Did you observe the handing of the money to Mr. Clark? A. Yes, sir.

Q. And how much was it?

A. I don't remember at this time.

Q. You observed the handing of the money? [47]

A. That is correct.

Q. Don't you know how much it was?

A. No, sir; I don't remember.

Q. Do you have any idea how much it was?

A. We have nothing to do with that.

Q. I know, but you observed the handing of the Government funds to Johnny Clark, and I am asking you how much money it was?

A. I can't tell you how much it was. I don't remember.

Q. Was that another partial observation you made of Johnny Clark?

A. No, sir; that was a full observation.

Q. How many bills were given to him—do you know that? A. No, sir; I don't.

Q. Were bills given to him? A. Yes, sir.

(Testimony of Chester G. Sprinkle.)

Q. You don't know how many?

A. No; I don't.

Q. Do you know the denominations?

A. No.

Q. Do you know whether they were marked?

A. I know that the serial numbers were recorded.

Q. Were the bills marked themselves? [48]

A. No, sir; they were not.

Q. Who gave the money to Johnny Clark?

A. Agent Gooder.

Q. That was before he left the automobile?

A. Yes, sir; before he left the automobile.

Q. What did Johnny Clark do then with the money? A. Put it in his pocket.

Q. Which pocket?

A. I don't remember which pocket.

Q. Coat pocket—pants pocket—what pocket?

A. I don't recall.

Q. You don't recall. Did you see him hand the money to anybody after he received this money?

A. In the car?

Q. Any time? A. No, sir.

Q. Did you ever retrieve the marked money?

A. Not that I know of.

Q. Was any attempt made to retrieve the marked money that evening in question? A. No, sir.

Q. Do you know whether or not the marked money was paid over to anyone?

A. Was what?

Q. Was the marked money paid to anyone? [49]



(Testimony of Chester G. Sprinkle.)

A. How do you mean that?

Q. Do you know whether or not Johnny Clark disposed of the money?

A. I witnessed Mr. Gooder check for money on Johnny Clark when Johnny got back in the car.

Q. Was there any money on him then?

A. No, sir.

Q. Do you know from your own personal knowledge to whom the money was given? Do you know of your own personal knowledge to whom the money was given?

A. It was given to Johnny Clark before he left the car.

Q. I know; but do you know of your own personal knowledge to whom Johnny Clark gave the money?

A. No, sir; I didn't.

Q. Did you make any attempt to enter that house which Johnny Clark entered to determine where the money went?

A. No, sir; we did not.

Q. Who owned that house?

A. I don't know. Who was living there?

Q. Pardon?

A. Do you mean who was living there, or who owned it?

Q. Who owned the house—do you know. [50] that?

A. No, sir; I don't.

Q. Describe the house.

A. It is a duplex, sitting on the southwest corner, 22nd and East Thomas, and it has a semi-parking place for cars in the back, and a walk or driveway going through there, and there is a long



(Testimony of Chester G. Sprinkle.)

porch—I believe it runs almost the full length of the back—and there are two entrances there.

Q. What entrance did Johnny Clark enter?

A. He entered the south entrance.

Q. You don't know who owned that part of the premises?

A. I know who lived there; I don't know who owned them.

Q. Do you know who the lessee was of that place?      A. Yes, sir; I believe I do.

Q. Who was that?

A. A party by the name of Bernice Fitzgerald.

Q. Bernice Fitzgerald?      A. Yes, sir.

Q. Is Bernice Fitzgerald a known narcotics addict, or pedlar, according to your record or experience?

A. Convicted narcotic pedlar or addict? She has been under investigation for quite some time.

Q. I am asking from your experience, ten years with the Seattle Police Department, and two and one-half years with [51] the Federal Narcotics Bureau, whether or not you would describe Bernice Fitzgerald as a pedlar of narcotics in this community?      A. Yes, sir; I believe so.

Q. In other words, you mean by that that she deals in narcotics, and buys and sells and distributes and dispenses?

A. Well, that is very undetermined.

Q. What do you mean, it is undetermined?

First you say you believe so, and now you say it is undetermined.

A. We have suspicions she has, yet we have

(Testimony of Chester G. Sprinkle.)

never come right down with the evidence. She is a suspected narcotic associate.

Q. Is she an addict?           A. I don't know.

Q. Have you ever had her in custody?

A. No, sir.

Q. Did you ever talk with her?

A. No, I have never talked with her.

Q. You say your "suspicions" led you to believe she is a pedlar or dealer in narcotics?

A. I wouldn't say a suspected pedlar. She was an associate; I believe she was using, but I don't know for sure.

Q. Now, who else occupied that house besides Bernice [52] Fitzgerald as a permanent resident?

A. I don't know, other than the Oriental party I saw come out.

Q. Can you tell me who the Oriental party was?

A. Can I tell you who he was?

Q. Yes.           A. I don't know, sir.

Q. When you say Oriental party, was it Japanese or Chinese?

A. It just looked like a small Japanese fellow. He could have been Chinese.

Q. Had you seen him there before?

A. No; I haven't.

Q. Do you know anything about his activities?

A. No.

Q. So far as narcotics are concerned?

A. No, sir.

Q. What?           A. No; I don't.

Q. Who else was there besides the Japanese, or Chinese, and Mrs. Fitzgerald?

(Testimony of Chester G. Sprinkle.)

A. I have no idea.

Q. How many rooms in the house?

A. I don't know that.

Q. You don't know anything about the interior at all? [53]

A. No, sir; I have never been in there.

Q. You don't know who else had access to the house, as far as living there, other than the Japanese and Bernice Fitzgerald, is that correct?

A. And Mr. Blassingame.

Q. You say Mr. Blassingame had access to the house? A. Yes, sir.

Q. What made you think he had access to the house?

A. We have seen him several times. I have seen him myself come and go in the place.

Q. I thought you told me a few minutes ago you had not seen the house before?

A. I have seen the house on numerous occasions.

Q. Who else did you see going to and from the house besides the Japanese, Bernice Fitzgerald, and Blassingame?

A. I can't recall who else I have seen coming and going, other than Miss Fitzgerald and Mr. Blassingame. I don't believe I have ever seen anybody else but those two. Whether they had somebody with them, I can't recall.

Q. But you have seen other people go in there—is that right? A. I don't believe so.

Q. You don't?

A. I don't believe I have; no, sir. [54]

(Testimony of Chester G. Sprinkle.)

Q. How often were you around that house prior to May 29, 1956?

A. Oh, possibly six or seven, and maybe eight or nine times. We drifted by and maybe stopped a few moments. We checked to see what cars were in the vicinity.

Q. But you never went in the house, or looked at the house, or determined who else was in the house?      A. No, sir.

Q. Do you know on this evening in question who had been in the house prior to your arrival?

A. No; I have no idea.

Q. Do you know who was in the house at the time Johnny Clark entered this house on the evening in question, May 29, 1956?

A. Other than Mr. Blassingame, no, sir.

Q. You don't know if anybody else was there?

A. No, sir.

Q. I thought you testified on direct examination that Mrs. Fitzgerald entered the house?

A. She entered after Mr. Clark went in.

Q. That is what I said—who else was in the house—do you know?

A. I beg your pardon. Mrs. Fitzgerald entered a few moments after.

Q. And the Japanese? [55]

A. The Japanese wasn't in that part of the house.

Q. He stood on the porch?

A. He came out of the other entrance.

(Testimony of Chester G. Sprinkle.)

Q. Do you know if anybody else was in that house that night?      A. No, sir.

Q. Do you know of your own personal knowledge who else was in that house besides, now, Mr. Clark, Miss Fitzgerald, and when you saw Mr. Blassingame step out the door?

A. I don't know who else was in there.

Q. Possibly there could have been other people in the house?      A. Yes, sir.

Q. Are you familiar what entrances there are in this particular unit that we are discussing?

A. No; I am not.

Q. What?      A. No; I am not.

Q. Do you know whether there is another entrance to this particular unit?

A. Excuse me. Another outside entrance?

Q. Yes.

A. I don't know. Actually, I can't even remember whether there is a front entrance to it, or whether they all used the rear entrance. [56]

Q. You don't know whether there is a rear entrance or front entrance?

A. I know there is a rear entrance.

Q. Do you know whether there is a front entrance?

A. I believe there is, but I just can't possibly place it right now. We have always observed the back.

Q. Did you ever observe the front entrance?

A. No, sir.



(Testimony of Chester G. Sprinkle.)

Q. Did you observe the front entrance May 29, 1956?      A. No; I did not.

Q. Do you know whether or not any search of that house was made that evening?

A. Not to my knowledge.

Q. After Mr. Clark came out of the house?

A. Not to my knowledge.

Q. Was Mr. Blassingame placed under arrest that night?      A. No; he was not.

Q. You didn't go in and arrest him?

A. No, sir.

Q. Do you know when Mr. Blassingame was arrested in relation to the incident that occurred May 29, 1956?      A. It was some time later.

Q. What do you mean by "some time later"?

A. Possibly one and one-half months later. [57]

Q. One and one-half months later?

A. Maybe one month; pretty close to that.

Q. Did you hire Mr. Clark, or did the Government agents hire Mr. Clark?

A. We do not hire anybody to assist us.

Q. You mean "we," talking about the Seattle Police Department? Is that correct?

A. Yes, sir.

Q. Do you know what arrangements were made with Mr. Clark, so far as his employment with the Federal Government is concerned that evening?

A. What, sir?

Q. Do you know, that evening in question, what arrangements were made with Mr. Clark, so far as he being in their employ?      A. Yes, sir; I do.

Q. What was that?



(Testimony of Chester G. Sprinkle.)

A. They were notified by Detective Waitt and myself, and we had furnished them with the information, and were going to get Johnny Clark for the purpose of buying narcotics.

Q. I am asking what the Government paid Johnny Clark, or what were the terms and conditions of the employment of Johnny Clark by the Federal Government on the evening in question?

A. I don't know of any additional [58] compensation—are you talking about——

Q. I am talking about compensation. What do you mean by “additional compensation”?

A. Well, I guess I just don't understand you.

Q. All right. I will try and rephrase it. You tell me that the Seattle Police Department never employs an informer; is that correct?

A. Yes, sir.

Q. And you tell me that the Federal Government does employ informers on these cases; is that correct?

A. I don't know.

Q. Let me ask you this question: Was Johnny Clark employed by the Federal Government on May 29, 1956?

A. By the Federal Government as an employee?

Q. As an informer, rather?

A. He was being used as a special employee that night.

Q. Do you know the terms and consideration passed between the Government and Johnny Clark for his services as an informer?

(Testimony of Chester G. Sprinkle.)

A. I don't believe they made him any terms or consideration.

Q. Pardon?

A. I don't believe the Government made Johnny Clark [59] any terms or consideration.

Q. You say he received no remuneration?

A. Not that I know of, no, sir.

Q. Or any threats or promises made to Johnny Clark?

A. Not from the Government's side, I don't believe.

Q. From your side?                      A. Yes, sir.

Q. What threats or promises were made from your side?

A. No threats were ever used against Johnny Clark.

Q. You said they were. Now you say they weren't.

A. No threats were used against Johnny Clark.

Q. What promises by your division to Johnny Clark?

A. No promises were made to Mr. Clark either by our side, by the city side.

Q. What about the Federal Government's side?

A. I don't know what they may have told him. I may have misunderstood you. I mean, an arrangement was made between Mr. Clark and Detective Waitt and myself.

Q. I understand that. I am asking what remuneration Mr. Clark was to receive for the services rendered?

(Testimony of Chester G. Sprinkle.)

A. None at all, so far as we are concerned.

Q. So far as the Government is concerned, do you know that?      A. I don't know. [60]

Q. Was anything ever said by you or persons under your supervision or by the Federal agents, so far as you are concerned, whereby Johnny Clark was to perform services for your division and the Federal Government division and on the promise that he would not have his parole revoked?

A. Not on a promise; no, sir.

Q. What was it then?

A. We would try to help that situation, but we cannot promise.

Q. You would try to help the situation; will you explain what the situation was?

A. Some time prior to this, approximately one month, possibly six weeks, during an investigation, we took Johnny Clark out of a place and we lodged him in the city jail.

A quantity of narcotics were found in the place, and that is when we began our talking with Johnny Clark. He agreed to assist us in making some purchases of evidence of narcotics, or narcotics for evidence.

Q. In exchange for what, now, is what we are getting at? How were you helping the situation?

A. In exchange for consideration for the plight that he was in.

Q. Did you promise him that you would do everything in your power to see that he wasn't sent

(Testimony of Chester G. Sprinkle.)

back to McNeill [61] Island or that his parole was not lifted?      A. Yes, sir.

Q. When did you make those promises?

A. That was about the time we had him in the city jail.

Q. And did you keep that promise?

A. To the extent that we had told Johnny we would try; that if he would go down and if he would try and stay away from narcotics, and be a good citizen.

Q. Are you aware that in September, 1956, that an attempt was made to revoke Johnny Clark's parole in the United States Federal Court?

A. No, sir; I am not.

Q. You are not aware of that?      A. No, sir.

Q. You have no personal knowledge or personal observation of any transaction that took place within that duplex on the night of May 29, 1956?

A. Transaction inside?

Q. Yes.      A. No; I haven't.

Q. You have no personal knowledge of personal observation as to from whom Johnny Clark obtained the alleged narcotics?

A. No, sir; no personal knowledge.

Q. And no personal observation? [62]

A. No, sir.

(Whereupon, there was a brief pause.)

Q. After Johnny Clark returned from the home, what did you do with him then—turn him loose?

A. No, we—he got in the Government car, and

(Testimony of Chester G. Sprinkle.)

we drove directly to the Federal Office Building—the Narcotics—or the United States Courthouse here, in the Narcotics Office, downstairs.

Q. Did you take him into the building, or not?

A. Yes, sir.

Q. Did you go in with him? A. Yes, I did.

The Court: Can you finish this up, Mr. Chavelle?

Mr. Chavelle: No, I haven't.

The Court: I say, can you?

Mr. Chavelle: Yes, I can finish in about five minutes.

The Court: All right; I thought we would finish, if you are about through. Do you have any redirect, Mr. Roberts?

Mr. Roberts: I have about three questions.

The Court: Well, we will recess until 1:45.

Members of the jury: Bear in mind the admonition given you on the occasion of the recess earlier this morning, and heed it on this occasion.

Be here a few minutes before 1:45 o'clock.

You may now be excused, and the court will remain in session while you leave.

(Whereupon, the jury retired from the court room.)

The Court: Court will recess until 1:45.

(Whereupon, at 12:09 o'clock p.m., a recess was had in the within-entitled and numbered cause until 1:46 o'clock p.m., January 15, 1957, at which time, counsel heretofore noted, includ-



(Testimony of Chester G. Sprinkle.)

ing Mr. Kosher, being present, the following proceedings were had, to wit): [64]

#### Afternoon Session

The Court: In the case on trial, we are ready to proceed, are we?

We will call the jury.

Are these witnesses, Mr. Chavelle?

Mr. Chavelle: No, your Honor.

The Court: With both counsel here, I assume if one counsel starts with a witness, the same counsel will finish.

Mr. Chavelle: Yes, Your Honor, that is right.

(Whereupon the jury was returned to the courtroom.)

The Court: You may be seated.

It is stipulated that the jury and the defendant are present in the court room?

Mr. Roberts: So stipulated.

The Court: Mr. Chavelle; Mr. Kosher—you stipulate?

Mr. Chavelle: Yes, Your Honor.

The Court: All right. You may proceed with cross-examination.

Mr. Chavelle: Yes, Your Honor.

Q. (By Mr. Chavelle): Mr. Sprinkle, directing your attention once again to the person referred to by you as Bernice Fitzgerald, [65] whom you saw going into these premises on the 19th day of—29th



(Testimony of Chester G. Sprinkle.)

day of May, 1956, do you know anything about her activities as a prostitute?           A. No, sir.

(Whereupon, the witness coughed.)

A. (Continuing): Excuse me. I don't hear too well. I know her as "Chinky," and I just recently found out her name.

Q. What alias does she use?

A. "Chincky."

Q. Chinky; now directing your attention to June 19th, I believe you stated on direct examination that Johnny Clark remained in the car with you?

A. At what time, Mr. Chavelle?

Q. When you first contacted him at 7th and Madison, or 7th and Cherry?

A. Yes, that is correct.

Q. Now, did you go any place from that location after you met Johnny Clark?

A. Not until the other officers arrived back there.

Q. And then where did you go?

A. We went down to the Seattle Police Department, Narcotics Room.

Q. And for what purpose?

A. To examine the Exhibit No. 2, that I [66] identified here.

Q. For fingerprints?

A. That is one part of it; to check the fingerprints, and also to mark it for identification.

Q. And you examined it for fingerprints?

A. I didn't, myself.

Q. Was it done in your presence?

(Testimony of Chester G. Sprinkle.)

A. Yes, it was.

Q. Were any fingerprints obtained from Plaintiff's Exhibit No. 2?

A. I don't believe any usable prints were obtained.

Q. Were there prints obtained or not?

A. I don't remember, Mr. Chavelle. Somebody else handling the printing of it.

Q. You said there was an endeavor to obtain fingerprints from Plaintiff's Exhibit No. 2, and it was performed in your presence?      A. Yes.

Q. Now, I am asking you, if you were there, whether or not you know if any fingerprints were obtained?

A. No; no familiar prints were obtained.

Q. All right.

Mr. Chavelle: That answers my question. Thank you. I believe that is all, sir. [67]

#### Redirect Examination

By Mr. Roberts:

Q. Mr. Sprinkle, directing your attention back to the time that Johnny Clark was frisked or examined on May 29th, before he went to the house at 23rd and Thomas, you testified that Narcotic Agent Gooder had, as his special duty, or his particular duty, the task of frisking or examining the person of Johnny Clark; is that correct?

A. That is right.

Q. Did you have any specific task or purpose to accomplish at that time?      A. Yes.

(Testimony of Chester G. Sprinkle.)

Q. Tell the jury what you were doing in addition to watching this?

Mr. Chavelle: This has all been gone into; not proper redirect. He testified on direct examination what his duties were that night.

The Court: Insofar as it may explain his responsibility other than the observing of the search of the person of Clark, I think it may be admissible, limited only to that.

Mr. Roberts: That is the only purpose of the question, Your Honor.

A. Detective Waitt and I were experimenting with a new type of recording device which we were placing on Johnny [68] Clark at that time, and we had to place it on him by removing his shirt and coat, and we were busy doing this, and strapping the machine on, and getting it ready to go.

Q. (By Mr. Roberts): Were you also instructing him on how to use this device?

A. Yes, sir..

Q. Was the device successful that evening?

A. No, it was not. There was a mechanical difficulty in it that made the recording of no value.

Q. Had you ever used such a device before?

A. That was——

Mr. Chavelle: I will object, whether it was used before; not material.

The Court: Objection sustained.

Q. (By Mr. Roberts): What authority do you have, Officer Sprinkler—or, pardon me, Officer Sprinkle—to promise individuals like Johnny Clark

(Testimony of Chester G. Sprinkle.)

that their probation will not be revoked if they cooperate with you?

Mr. Chavelle: I don't think that is proper re-direct examination, Your Honor.

The Court: Objection sustained.

Mr. Roberts: I believe that the inquiry is pertinent, Your Honor. [69]

The Court: The objection is sustained.

Q. (By Mr. Roberts, continuing): Describe in detail, if you recall, the promise, if any, you made or anyone in your presence made to Clark, to cooperate in this particular case?

Mr. Chavelle: Object to that as not proper re-direct examination. He already testified on direct examination he never made such a promise, or had no authority to make such a promise, and his Department never made such promises, or employed informers.

It is certainly outside the scope.

The Court: He indicated he had told this man that he would further his interests with respect to continuation of probation.

Isn't that in substance what he testified?

Mr. Chavelle: That is right.

The Court: Insofar as that may be a promise, as to that factor or that issue, I think he might testify.

The Witness: Is it all right to answer that?

The Court: Yes; related solely to that question.

A. The only thing we told Johnny was that we

(Testimony of Chester G. Sprinkle.)

could not, as we tell all the people we work with, that we cannot——

Mr. Chavelle (Interposing): I am going [70] to object to this as hearsay, conversation with Johnny. He can say in substance what was done, but not the conversation not in the presence of the defendant here.

The Court: It was opened up on cross-examination. Objection overruled.

A. (Continuing): We told Johnny that we can't promise him anything, and that the main consideration we could show him is that if he would assist us in any way whatsoever, that we could call it to the attention of the respective prosecuting attorneys of the courts for any consideration they may give him.

Mr. Roberts: I have no further questions.

Mr. Chavelle: That is all, sir.

(Witness excused.)

Mr. Roberts: Mr. Gooder.

The Court: Do you want this witness excused?

Mr. Roberts: Yes, if Your Honor please.

The Court: Mr. Chavelle, any reason to hold him under subpoena?

Mr. Chavelle: No, not at all.

Mr. Roberts: May I also request that Mr. Ringstrom be officially excused?

Mr. Chavelle: No objection to that, Your [71] Honor.

The Court: All right. They may both be excused



from further attendance.

Mr. Roberts: Mr. Gooder, please. [72]

LAVERN E. GOODER

upon being called as a witness for and on behalf of the plaintiff, upon being first duly sworn, testified as follows:

The Clerk: Will you state your full name and spell your last name, please?

The Witness: Lavern E. Gooder—G-o-o-d-e-r (spelling).

The Clerk: Lavern, L-a-v-e-r-n? (Spelling.)

The Witness: Yes.

Direct Examination

By Mr. Roberts:

Q. Do you go by any other name, other than Lavern E. Gooder?

A. Yes, I am commonly known by my nickname, "Sam."

Q. Where do you reside, Mr. Gooder?

A. 142 East 166th, Seattle Washington.

Q. What is your occupation?

A. Federal Narcotics Agent.

Q. Attached to what office?

A. The Seattle office.

Q. And were you so employed during the month of May, 1956?           A. Yes, I was.

Q. Directing your attention to on or about May 29th, [73] 1956, state whether or not you had any dealings with an individual known by the name of Johnny Clark?           A. Yes, I did.

Q. Will you describe the circumstances leading



(Testimony of Lavern E. Gooder.)

to a meeting with Clark that night or that day?

A. Myself and Agent Fahey met in the 7th and Madison parking lot with other narcotics agents and Seattle narcotic officers from the Seattle Police Department, and we had some conversations there, and then we immediately drove to 19th and East Roy.

We arrived there. Mr. Clark entered the outside phone booth, and Mr. Sprinkle, Detective Sprinkle, also went into the phone booth with him there.

A phone call was made.

From this point Mr. Clark got into the Government automobile, which I was driving, with myself and Detectives Waitt and Sprinkle.

We drove to 21st and East Roy, where I stopped and got out of the car, and I entered the back seat with Detective Waitt and Mr. Clark, and I proceeded to search Mr. Clark's person, his clothes and so forth, for any concealed narcotics.

After the search, no narcotics were found.

I furnished him with \$25.00 Government-advanced funds for which he had signed a receipt previous to this time. [74]

Q. Pardon me. Let me interrupt you and ask you what you mean by Government advance funds?

A. It is a receipt on which we list the serial numbers of all money which is expended for evidence purposes.

It has a two-fold purpose of, later during any arrest and so forth, we check the monies found on any of the defendants to see if it checks with our

(Testimony of Lavern E. Gooder.)

serial numbers that were used in previous purchases.

Q. You use it for evidence, then?

A. Yes. And also it is more or less of an accounting of all of the money that is spent for evidence purposes.

Q. In accounting to whom and by whom?

A. It is actually a sworn statement, which we return to our District Supervisor, who accounts for all the money to the Congress of the United States.

Q. Is that part of your duty, to account for such funds? A. Yes, it is.

Q. Now, then, you say you searched the person of Johnny Clark? A. Yes.

Q. Let me interrupt you here and ask you, who is Johnny Clark?

A. He is a special employee of the Bureau of Narcotics at that time. [75]

Q. And what do you mean by special employee?

A. He was assisting the Government in making various narcotics cases.

Q. Does that mean he is a stool piegon or informer? A. More or less.

Q. Is he a narcotic addict himself?

Mr. Chavelle: I object to that, Your Honor; that—

Mr. Roberts: I will withdraw the question.

Q. (By Mr. Roberts, continuing): After searching Johnny Clark, and giving him his \$25.00, what did you then do?

A. I then returned to the driver's seat of the automobile and drove to 22nd Avenue and parked just south of East Thomas.

(Testimony of Lavern E. Gooder.)

Q. Then what happened?

A. At this point, approximately 9:40, or shortly before, Johnny Clark left the Government automobile, followed by Detective Sprinkle.

I observed him walk north on 22nd to East Thomas, and on East Thomas, he turned east and disappeared from my view.

Q. What then happened?

A. We waited until approximately 10:00 p.m., at which time Mr. Clark reappeared, walking on East Thomas, and [76] he turned down 22nd and returned to the Government automobile.

Q. And then what did you do?

A. He surrendered to me, Mr. Clark surrendered to me, a small, white paper bundle.

I had him place his initials on the bundle, after which I initialed it, and also Detectives Waitt and Sprinkle.

Mr. Roberts: May I see Plaintiff's Exhibit Number 1?

(Whereupon, exhibit was handed to counsel by the Clerk.)

Q. (By Mr. Roberts): I will ask you, Mr. Gooder, to examine the contents of Plaintiffs Exhibit No. 1, and state what it is, if you know?

A. Yes, this is the bundle made from what appears to be newsprint from a slick magazine, which was given to me on May 29, 1956, by Johnny Clark, at approximately 10:00 o'clock p.m.

Q. And you said you initialed it at that time?

(Testimony of Lavern E. Gooder.)

A. Yes, I did.

Q. Who else, if anyone else, also initialed it in your presence?

A. I observed Johnny Clark, and also Detectives Waitt and Sprinkle, at that time. [77]

Q. Now, do you know where Detective Waitt is today?

A. Yes, I believe he is out in the witness room.

Q. Available as a witness? A. Yes.

Q. He remained with you in the automobile?

A. Yes.

Q. While Clark was gone—is that correct?

A. Yes, he did.

Q. Now, after receiving this bindle back from Clark, what then did you do?

A. As I recall, we drove a few blocks away from the immediate area, where we again stopped, and while the detectives were removing some recording gear from Johnny Clark's person, I again went through his pockets, and so forth, searching for the \$25.00 in Government advance funds, which I did not find.

Q. Which you did not find.

Concerning the bindle which you received from Clark, what did you do with that?

A. We returned to the Narcotics Office in the—in this building, the Court House, and the bindle was also initialed by Agent Fahey, and it was then decided that we should attempt to raise fingerprints on it, and lock it in my desk drawer, the desk to which I have the only key in my office; and on the

(Testimony of Lavern E. Gooder.)

31st of May—the 30th was a holiday—the 30th of May it was taken to the Police [78] Laboratory, and checked for fingerprints, and I then carried it to the United States chemist, where it was sealed in the presence of Agent Fahey, and turned over to the custody of the United States chemist, Mr. Ringstrom.

Q. Will you examine the envelope, Plaintiff's Exhibit No. 1, and state whether or not you recognize any of the writing on it?

A. Yes; this is all my writing.

Q. And do you recognize any other writing on it?

A. This is also my writing here.

Q. On the reverse side?

A. On the reverse side.

Q. And is there any other writing that you recognize?

A. I believe this writing here is Agent Fahey's writing.

Q. Well, do you know it is; have you ever seen his handwriting?

A. Yes, I have; and I also witnessed him write those words.

Q. And did you lock and seal this envelope before delivering it to the chemist?

A. Yes. I also forgot to mention I performed a Marquis reagent test on the contents of the bundle.

Q. What is the Marquis test?

A. It is a test which includes hydrochloride [79] acid and formaldehyde, in which the presence of



(Testimony of Lavern E. Gooder.)

opium alkaloids gives a positive reaction, or a cherry red color.

Q. What was the result of your test in this case?

A. Positive reaction for opium alkaloids, in this case heroin.

Q. In this case heroin, you say? A. Yes.

Q. And when did you deliver it to the chemist?

A. On May 31, 1956.

Mr. Roberts: I have no further questions.

#### Cross-Examination

By Mr. Chavelle:

Q. Directing your attention to the location on 19th and East Roy Street, Mr. Gooder, did you have anything to do with witnessing the telephone conversation itself? A. No, I did not.

Q. Now, after you left that location, you said you went where?

A. Approximately two blocks east on East Roy, to about 21st.

Q. And you say you searched Johnny Clark at that time? A. Yes.

Q. By "search," do you mean you went through his pockets? [80]

A. I went through his pockets, his sox and shoes. As I recall, as the detectives were putting on the recording device, his shirt was off and his coat was off, and actually the only thing he had on was his undershirt, and I checked under his arms—a thorough search.



(Testimony of Lavern E. Gooder.)

Q. Who witnessed that?

A. Detective Waitt, and I believe Detective Sprinkle witnessed part of it, although he was busy with the recording gear.

Q. He was present at the time, and all the time?

A. Yes.

Q. Detective Sprinkle? A. Yes.

Q. What remuneration had you promised Mr. Clark to act as a special employee, or informer, or stool pigeon? A. Pardon?

Q. What remuneration had you arranged for Johnny Clark, who has been described as a stool pigeon and informer here?

A. In previous conversation with Mr. Clark, which I had no part of, but I was there—I was there, I was present—it was brought out that any assistance that we could be, in, I believe it was some type of case pending against him.

Q. What type of case was that. [81]

A. I am not sure. I believe it was some type of murder case.

Q. Murder case? A. Murder.

Q. Murder?

A. Murder, I believe, yes. I believe someone told him, I don't know who, that whoever would be handling the case would be told of whatever he'd done to assist the Government. That is the only thing I know.

Q. That the Government would assist him in this murder charge, is that right?

A. I am not sure. As I say, there was some type

(Testimony of Lavern E. Gooder.)

of case pending against him. I don't know whether there was another case or not.

Q. In return for the service that he might render your Department, Bureau of Narcotics, that someone in your Department would speak to the prosecuting officials pertaining to this murder charge under which Johnny Clark was charged, to assist him; is that right?      A. I believe so.

Q. Do you know what assistance was rendered?

A. No, I do not.

Q. Who would know that?

A. I don't know.

Q. Who is in charge of your Department? [82]

A. Mr. Crisler.

Q. (Continuing): That handles those matters?

A. Well, Mr. Crisler is in charge of our Department.

Q. Who would be the man who would be instrumental in speaking to prosecuting officials to help Johnny Clark in connection with any charge which he might be facing?

A. I imagine it would be Mr. Crisler.

Q. Do you know who actually would carry out such a promise of such aid or assistance to Johnny Clark—what individual?      A. No, I do not.

Q. You think it might be Mr. Crisler?

A. It is possible, yes.

Q. Was there also some question of Johnny Clark in connection with the assistance he might render your Department that you would try to see that parole was not revoked?

(Testimony of Lavern E. Gooder.)

A. Not while in my presence, no.

Q. Did you ever hear of such a conversation?

A. No, I did not.

Q. Do you know whether or not any attempts, subsequent to May 29, or June 19, 1956, were made to revoke his parole?

A. Yes, I believe there was an attempt.

Q. What connection did you have with that attempt?

A. Let me think. There was an affidavit, I believe, [83] that was filled out by Agent Fahey and myself regarding conversations we had had with Mr. Clark during May and June, 1956, having to do with his addiction, I believe.

Q. That was in support of a petition to revoke his parole and send him back to McNeill Island, is that correct?

A. Yes, I believe so.

Q. Do you know what was done with those affidavits after you executed them?

A. I believe they were turned over to the Probation Office.

Q. Do you know the result of that hearing, if there were a hearing?

A. Yes, I was in court the day of the hearing.

Q. Before what judge was that?

A. Judge Boldt, I believe.

Q. Judge Bowen?

A. Bowen, yes, I believe it was.

Q. What was the result of that hearing?

A. They didn't revoke his parole.

Q. They did not? A. No.

(Testimony of Lavern E. Gooder.)

Q. Did you testify that day in court?

A. No, I did not.

Q. Did you ever retrieve the \$25.00 Government funds? Do you know where it is now? [84]

A. No, I do not. It was never found.

Q. Did you make any search for it?

A. On Mr. Clark, you mean?

Q. Anyone.

A. I searched Mr. Clark after he had surrendered the bindle of heroin to me.

Q. Did you search the premises where he allegedly went?

A. Not at that time, no; not at that time.

Q. You didn't search the premises? A. No.

Q. What do you mean by "not at that time"?  
Did you ever search the premises? A. No.

Q. You never recovered the marked money, right? A. Right.

Q. Directing your attention again to the May 29, 1956, date, do you know who the occupants of the house in which Mr. Clark allegedly went were that evening?

A. I don't know who was in the house, no.

Q. Do you know during the time that Mr. Clark was in the house who came from the house or went into the house? A. No.

Q. Do you know whether any of the officers entered the premises that evening? [85]

A. Any of the officers entered the premises?

Q. Yes. A. No, I do not.

(Testimony of Lavern E. Gooder.)

Q. Well, I will ask you, do you know whether or not any officers did actually enter the premises that evening?

A. I don't believe any of our officers entered the premises, no.

Q. What do you mean by "our officers"?

A. The Seattle Police Narcotic officers and the Narcotic Agents.

Q. Do you know of anyone else who went in the premises that evening? A. Yes, Johnny Clark.

Q. Any officers of any type or description?

A. I don't believe so, no.

Q. And after Johnny Clark returned, and when he delivered to you the Plaintiff's Exhibit No. 1, was any arrest made that evening?

A. No arrest was made.

Q. When was the arrest made in this case, in relation to the alleged activities occurring on May 29, 1956? A. September 27, I believe.

Q. September 27th?

A. I am not too sure of that date.

Q. And from May 29, 1956, until September 27, 1956, [86] you had seen Mr. Blassingame in the City of Seattle, had you not? A. Yes.

Q. And you did not arrest him until September 27, 1956? A. Correct.

Q. He was available for arrest at all times during that period from May 29, 1956, until September, was he not, so far as you know?

A. So far as I know of my own knowledge. I only saw him once or twice during that period.



(Testimony of Lavern E. Gooder.)

Q. But he was in Seattle during that period?

A. During the times I saw him.

Q. And that was during the summer of 1956?

A. Yes.

Q. Do you know who the lessee or the owner of the premises were in relation to the activities that took place on May 29, 1956?

A. I don't know who owned the building. I know who was supposed to be living there.

Q. Who was the lessee; do you know that?

A. A woman by the name of Bernice Fitzgerald.

Q. Bernice Fitzgerald?

A. Better known as "Chinky Johnson" to us.

Q. "Chinky Johnson"—that is her alias. Do you [87] know what her occupation is, or what she does for a living, from your acquaintance with her?

A. No, I do not.

Q. Do you know whether she deals in or peddles narcotics?

A. No, I do not.

Q. Do you know whether she has any activities in connection with narcotics?

A. I don't know.

Q. Do you have any suspicions along that line?

A. We have our suspicions.

Q. You have your suspicions based upon her association with narcotics addicts and peddlers?

A. Yes.

Q. Do you know whether or not she is a prostitute?

A. I don't know.

Q. Do you know anyone else who was in that house—living in that house?

A. No, I don't.



(Testimony of Lavern E. Gooder.)

Q. Do you know the Oriental that was there that night?  
A. No, I don't.

Q. Are you familiar with the physical set-up of the house, and the number of rooms, and the different entrances, and what not? [88]

A. The different entrances, yes; the interior of the house, no.

Q. How many entrances are there?

A. Two, I believe.

Q. A back and a front entrance?

A. Yes.

Q. Do you know what entrance Johnny Clark used the evening in question?

A. The back entrance.

Q. The back entrance; do you know whether or not any—how many people went in, and from the house that night in question?

A. No, I don't.

Q. Did you obtain any fingerprints on Plaintiff's Exhibit No. 1?  
A. No.

Q. Although you attempted to?

A. The Seattle Police chemist did, yes.

Q. Unable to obtain any fingerprints?

A. Yes.

Q. Did you personally witness the transfer of Plaintiff's Exhibit No. 1 from one person to another, other than Johnny Clark, the evening in question?  
A. No, I did not.

Q. At the time Johnny Clark was in the home, do you [89] know who was in the home with him at that time?  
A. No, I don't.

(Testimony of Lavern E. Gooder.)

Mr. Chavelle: I believe that that is all, sir.

Mr. Roberts: I have no further questions, your Honor.

May this witness also be excused, your Honor?

The Court: Any reason to hold him?

Mr. Chavelle: None whatsoever, your Honor.

The Court: You may be excused from further attendance, Mr. Gooder.

Mr. Gooder: Thank you.

(Witness excused.)

Mr. Roberts: Mr. Fahey. [90]

#### CHARLES FAHEY

upon being called as a witness for and on behalf of the plaintiff, and upon being first duly sworn, testified as follows:

#### Direct Examination

By Mr. Roberts:

Q. Would you please state your full name?

A. Charles Fahey, F-a-h-e-y (spelling).

Q. Where do you live, Mr. Fahey?

A. 4011-142nd in Southeast Bellevue.

Q. What is your occupation?

A. Treasury Agent, Narcotics, stationed at Seattle.

Q. How long have you been a Treasury Agent for the Bureau of Narcotics?

A. Since August 23, 1943.

Q. And how long have you been stationed here in Seattle?

(Testimony of Charles Fahey.)

A. Off and on since January, 1950.

Q. And were you so employed in the Seattle office during the months of May and June of the year 1956?

A. Yes, sir, I was.

Q. Directing your attention to on or about May 29, 1956, state whether or not you met with a man by the name of Johnny Clark? [91]

A. Yes, sir, I did.

Q. Would you describe the circumstances leading to that meeting?

A. Some other officers and I waited in the parking lot at 7th and Madison, and three Seattle detectives arrived with Johnny Clark, and I met him there.

Q. And then what did you do?

A. I went in the police car to our garage and picked up the Cadillac, a Government car, and with Detectives Chan Kirschner and Bill Henaby, I remet the officers, the other officers and Johnny Clark, at 19th and East Roy.

Q. You say the Government car is a Cadillac?

A. Yes, sir.

Q. Why is that?

Mr. Chavelle: I object to that as not material.

The Court: Objection sustained.

Mr. Roberts: They might be curious, your Honor.

Q. (By Mr. Roberts, continuing): All right. Where did you meet, once again, with the Seattle Police Department officers?

(Testimony of Charles Fahey.)

A. At 19th and East Roy in Seattle, Washington.

Q. And what happened there?

A. Johnny Clark made a telephone call in the public [92] phone booth. Detective Sprinkle was in the booth. I was outside. I had Mr. Clark sign a receipt. The detectives, Kirschner and Henaby, and I, left and parked our car and drove away from there and parked the car at 22nd and East John.

Q. Who was with you in your car?

A. Detectives Chan Kirschner and Bill Henaby, of the Seattle Police Narcotics Squad.

Q. And where did you go in your car?

A. To 22nd and East John.

Q. And what did you do there?

A. We parked and took up a spot where we could see the apartment where Sam Blassingame was living.

Q. All right. Where is that apartment, if you know?

A. Oh, that address is the corner of 23rd and John; the address is right out of my mind, the street address.

Q. Well, that is immaterial.

What was the position of your car with relation to the apartment where Sam Blassingame was?

A. We were on the northwest corner of 22nd and John. We are about the distance of one-half of a city, downtown city block, from the rear entrance to this apartment.

Q. And did you have a view of the rear entrance

(Testimony of Charles Fahey.)

to the apartment? A. Yes, sir, we did.

Q. And what happened, if you know, to Johnny Clark [93] and the other officers with him?

A. He went with Agent Gooder and Detectives Sprinkle and Waitt.

Q. And did you see them again?

A. Yes, I did.

Q. Well, tell the jury what you observed in that regard?

A. About, oh, around twenty minutes to ten that evening the Government Ford with Agent Gooder and Detectives Sprinkle and Waitt and Johnny Clark arrived and parked ahead of us, which would be south of the intersection at 22nd and Thomas.

Johnny Clark and Detective Sprinkle walked toward the, Chinky Johnson's apartment, where Sam stayed. Clark went on direct to the back door.

Mr. Chavelle: I object to that. He is assuming something here, your Honor, and we object to the answer and move it be stricken, assuming Chinky Johnson's is the place he lives. It was not responsive to the original question.

The Court: Well, the portion of the answer, "where Sam stayed," may be stricken. Proceed.

A. (Continuing): He went down and entered the duplex, one of the duplex apartments.

Detective Sprinkle went down the middle of [94] the vacant lot and hid himself from my view.

Q. (By Mr. Roberts): Will you state whether or not you could observe Johnny Clark approaching the entrance to the apartment?



(Testimony of Charles Fahey.)

A. Yes, I could.

Q. Did you also observe Detective Sprinkle?

A. Yes, sir.

Q. Where was Sprinkle with relation to Clark when Clark was at the back door?

Mr. Chavelle: That is objected to as leading. He might ask what he saw.

Mr. Roberts: I will withdraw the question.

Q. (By Mr. Roberts, continuing): State what you observed as Clark approached the rear entrance to the building?

A. Detective Sprinkle separated and paralleled him going through the vacant lot, and perhaps twenty feet to the rear, and down in there some place Sprinkle squatted down, or disappeared from my view, in the grass.

Q. What did you observe about Clark?

A. Clark went to the back door, and I couldn't tell whether he knocked, or what. The door opened, and I could see Mr. Blassingame in the doorway, and then Clark entered.

Q. Then what happened? [95]

A. Oh, roughly five or ten minutes, a car drove by us that I recognized as Chinky Johnson's car, and parked at the alley. A woman got out and entered that same apartment, and was in there just a few minutes, and then left.

A couple of minutes after she left, in the neighboring apartment a man came out the back door and turned on a porch light and messed around the back porch some way, and left his lights on.



(Testimony of Charles Fahey.)

About ten o'clock the door opened. Mr. Blassingame stepped part way through the door and looked out and looked around and passed Johnny Clark out the door, and the door closed.

Q. How are you sure it was Sam Blassingame?

A. I could see him.

Q. Did you know Sam Blassingame at that time?

A. Yes, sir.

Q. How long had you known him prior to that time?

Mr. Chavelle: I will object to that; that is immaterial.

Mr. Roberts: Very well, your Honor; I will withdraw the question.

Q. (By Mr. Roberts, continuing): After Clark left the apartment, what then did you do?

A. After Clark left the apartment we rejoined the [96] officers and left the vicinity, and I drove the two detectives and myself to the Narcotics Office in this building.

Q. And what did you do there?

A. We took a statement; I reduced it to writing—a statement from Mr. Clark; and I believe at that time I marked some package of some heroin for identification.

Mr. Roberts: May the witness be shown Plaintiff's Exhibit No. 1?

Q. (By Mr. Roberts): I think it is in front of you. Will you examine the contents and state what it is, if you know?

A. This is the small packet of heroin that Agent

(Testimony of Charles Fahey.)

Gooder produced in our office when I rejoined him that night here in the Federal Narcotics Office.

Q. Is this what you just referred to as a packet of heroin?           A. Yes, sir.

Q. How are you able to be definite about that?

A. I believe Agent Gooder and I made a routine field test, and I was also present with Mr. Gooder when this was delivered to Chemist Ringstrom.

Q. Did you make any writing to indicate you were present or had anything to do with it?

A. I marked this. It bears my initials, among others. [97]

Q. And on that envelope in which that brindle is contained, is there any writing that you recognize as your own?

A. Yes, there is, where I did write on that, and I do recognize it.

Q. Very well. Now, inviting your attention to on or about June 19, 1956, state whether or not you met again with Johnny Clark on or about that time?

A. Yes, sir; I did, at a few minutes past nine p.m. here at 7th and Madison.

Q. Describe the circumstances leading to that meeting?

A. We met first with Deputy Marshal James Clark, Narcotic Agent Lee Holt, and Narcotic Agent Charles Du Puis, at the parking lot at 7th and Madison. and we had an appointment a few minutes after nine.

Detectives Sprinkle and Kirschner and Henaby drove up with Johnny Clark and we met.

(Testimony of Charles Fahey.)

Q. Without relating any conversation that took place, if any, tell us what you then did?

A. We held a short conference and immediately Agent Du Puis, Chan Kirschner and I raced to the fire plug at 26th and East Thomas.

Q. Who is Agent Du Puis?

A. He is Narcotic Agent Charles F. Du [98] Puis.

Q. Is he a Federal or State officer?

A. Federal Narcotics, the same as myself.

Q. Who is Chan Kirschner?

A. A Seattle City Detective, stationed with the Narcotic Squad.

Q. You stated you three individuals went where?

A. To the fireplug at 26th and East Thomas.

Q. And I will now ask you to describe the intersection at 26th and East Thomas.

A. Well, it is like what you might call a dog's leg. There are two roads that run together.

Q. What direction does 26th Avenue run?

A. 26th is north and south, and Thomas is, of course, east and west.

Q. All right. Does 26th Avenue proceed north through that intersection?

A. No. No, it dead-ends at Thomas. They both join. I don't know how to describe it.

Q. Does East Thomas run to the east of that intersection?

A. No, it ends at 26th.

Q. I want you to describe as best you can the actual physical relationship.

(Testimony of Charles Fahey.)

A. It makes a right angle. You drive north on 26th. It dead-ends at Thomas, which begins and runs east [99] from 26th.

Q. So that Thomas does not go through to the west? A. No, it makes an "L."

Q. What did you observe when you looked to the west of that intersection?

A. Looking west, you are looking directly into a brushy, wooded bank, with a long flight of stairs leading up to Madison.

Q. All right; what do you observe when you look to the east of East Thomas?

A. Looking east you are looking downhill on Thomas, kind of a long corner to the first house, to the first—to the driveway, beyond the house, perhaps fifty or sixty—forty or sixty feet; some place in there, down the hill.

Q. Now, locate, if you will, the fireplug that you referred to in this intersection.

A. The fire plug would be the inside corner of the "L," which would be the southeast corner of the intersection.

Q. Now, state what lights, if any, were in that general area?

A. There is a street light, but it was not burning. Your nearest light is from Madison where it has those large, brilliant street lights. I don't know what you call them.

It throws a bright, bluish——

Q. (Interposing): Fluorescent light? [100]

(Testimony of Charles Fahey.)

A. I think that is what you call them.

Q. Or sodium vapor?

A. Something like that; a new-style light.

Q. What was the degree of visibility at the time you arrived at that intersection?

A. It was clear, and just a bit chilly, as I recall.

Q. What did you do when you arrived at the fire plug?

A. Agent Du Puis was driving the De Soto and Agent Kirschner and I got out with a flashlight and searched around the fire plug.

Q. Describe what you were searching in?

A. The fire plug is in that, what is called the parking strip between the road, and the sidewalk, and there was grass, perhaps two feet high—high grass—untrampled then; searched thoroughly around the plug; searched widening a little bit from that area, and then went back and had a little talk with Du Puis, and backed the car out of view, and he grabbed his flashlight and joined us, and the three of us searched.

We found—we went back——

Mr. Chavelle (Interposing): There is no question before the witness now, your Honor.

The Witness: I beg your pardon?

Mr. Roberts: I am asking what he did. It [101] is a narrative statement.

A. (Continuing): We all went back to Du Puis' car and pulled around the corner and half way down the hill.



(Testimony of Charles Fahey.)

Q. (By Mr. Roberts): Down what hill?

A. That is Thomas, that is on an incline.

Q. You traveled to the east, therefore?

A. Yes, sir; about three-quarters of a block.

Q. And then what did you do?

A. Du Puis pulled into the curb and cut his lights, and we were holding a little hurried conference, and Chan got out of the car, and we made a plan, and I am starting out and my coat is hung up on the ashtray or something, and Du Puis directed our attention back to the stairway and I see a man coming down the stairs. And Kirschner has already started to run, and I am behind him.

Q. What did you do?

A. We ran up the hill toward the man coming down the stairs. Kirschner is ahead fifteen or twenty feet, and I cut to the left in the yard, and I am in the parking strip in the grass. The man is going fast down the stairs. I am running up hill.

About the time—about the time the man is standing over the fire plug, I can feel headlights, and I hit dirt.

Q. What do you mean by “hit dirt”? [102]

A. I can feel lights silhouetting me, and I dropped flat and hid as best I could. To the best of my knowledge, Kirschner is doing the same.

As the car went by me, I am up and running again, and I believe I spoke to Chan and said, “Let’s get him.”

Mr. Chavelle: I will object to any conversation with Chan or anybody else there.



(Testimony of Charles Fahey.)

Q. (By Mr. Roberts): Approximately how far from the fire plug were you when you hit the dirt, as you said?

A. Gee, in feet, I don't know. What would I believe? Sixty. I would say sixty feet, fifty feet; something in there. I don't know.

Q. State whether or not you had a view of the fire plug from that position?

A. I think I could roughly—I don't know whether I can see the fire plug actually or not. I believe I can see the top of it, but maybe not until I am farther up the hill. I can't tell.

Q. Well, what next happened?

A. I am up and running, and the man has turned and gone on a fast trot back there up about four steps, and whirled around looking.

Q. Where is the car? [103]

A. The car has passed me, and I am up and running again. The car's headlights have him tagged on the steps.

Q. Who was it?

A. Mr. Blassingame.

Q. And then what happened? What did the car do, first of all?

A. The car went up and turned left, and to the best of my knowledge he killed his lights and dropped out of my—I can't recall the car beyond that.

Q. What did you yourself do?

A. I am running and joining Chan. The man has run up to the steps to about the first or second landing, and has whirled around again, and I

(Testimony of Charles Fahey.)

dropped down, and I am quiet. He is peering back down. He turned, and is running, and I am up and running, and I join Kirschner across the street even with the bottom of steps, but hid by the brush, looking up the hill; and Sam is walking back and forth up on the top of the steps.

Q. How far away from you was he at that point?

A. I don't know. Those are long steps, and it is a long climb. It is fifty feet or sixty feet. I am not good on distances.

Q. Why didn't you follow him up the steps?

A. I am partly out of breath. I couldn't catch him by then, and I am not certain of the evidence I have or [104] of the next move to make. I really——

Q. (Interposing): What do you mean by what "evidence" you have?

A. We didn't know what had actually transpired up to that point.

Q. Well, tell the jury what you did then?

A. Chan called to—there was a slam of a car door, and Sam disappears from our view, and Chan called to Du Puis, who rejoins me, and we are over at the fire plug, and turned our flashlights on, and there, sitting next to the plug, is a round white object.

Mr. Roberts: May I have Plaintiff's Exhibit No. 2, please?

(Whereupon, exhibit was handed to counsel by the Clerk.)

(Testimony of Charles Fahey.)

Q. (By Mr. Roberts): I will ask you to examine the contents of Plaintiff's Exhibit No. 2, and state what it is, if you know?

(Whereupon, there was a brief pause.)

A. Yes, sir, this is the object that lay beside the fire plug at 26th and East John.

Q. Who besides yourself observed that parcel lying by the plug?

A. Chan Kirschner and Agent Du Puis.

Q. And is this the same plug which you testified [105] earlier you thoroughly examined?

A. Yes, sir.

Q. What was the approximately length of time that elapsed between the time that you first examined the area around the plug, and the time that you found this parcel; how much time had elapsed?

A. Gee, that moved awfully fast. I would say we searched for three to five minutes. I would say the whole entire proceedings wouldn't be much over five or six minutes, including the search.

Q. Now, by the time that you first examined the fire hydrant and the area around it, and the time you discovered this parcel at its base, what other individuals, if any, did you observe in the vicinity of the fire plug?

A. There was nobody—there was nobody between the time we searched the fire plug and found this; there was no other person there?

Q. How about the man who was on the stairs?

A. Other than Defendant Blassingame.

(Testimony of Charles Fahey.)

Q. And will you state whether or not you observed him in the vicinity of the fire plug?

A. Yes, sir, I did.

Q. How close to the plug?

A. I would say I observed him standing right beside it, what you might say, over it. [106]

Q. Now, after you discovered this parcel at the plug, what then did you do concerning it?

A. I didn't move it until Du Puis came back and could see it laying there. All three of us saw it laying there. Then I picked it up and marked it for identification, and the other officers marked it for identification and we came back to 7th and Madison, the parking lot, and rejoined the other officers.

Q. What did you then do with the parcel?

Mr. Roberts: Strike that.

Q. (By Mr. Roberts, continuing): In whose possession was the parcel kept after it was picked up from the fire plug? A. Mine.

Q. And what did you do with it after you left that area and the 7th and Madison area?

A. We came to the City Narcotics Squad office and used their fingerprint powder and brushes and dusted it for fingerprints, a routine.

Q. What prints, if any, did you find?

A. None.

Q. And then what did you do with it?

A. Took it back to the office and weighed and sealed it in the presence of Agent Du Puis, and locked it in my desk. [107]

(Testimony of Charles Fahey.)

Q. And would you examine the envelope and state if you recognize any of the writing on it?

A. Yes, sir; it is all my writing with the exception of the witnessing on the weighing and sealing by Agent Du Puis.

Q. After you put it in your locked desk, what, if anything else, did you do?

A. I kept it until the 31st. The 30th was a holiday, Memorial Day, and the following day, the 31st, I delivered it to Chemist Ringstrom.

Mr. Roberts: I have no further questions.

#### Cross-Examination

By Mr. Chavelle:

Q. Directing your attention to the intersection of 26th and East Thomas Street, Mr. Fahey, will you tell me approximately what the grade is?

A. On East Thomas as it goes eastward from that intersection?

Q. What is the grade of the street going down the hill?

A. East Thomas—there must be a confusion in names here.

Q. What was the——

A. (Interposing): 26th and East John. [108]

Q. No. A. Do you refer to——

Q. No. Well, I will ask you this, then:

Where was the fire hydrant located, what intersection? A. 26th and East John.

Q. 26th and East John, you say; are you sure of that? A. I believe so.



(Testimony of Charles Fahey.)

Q. All right; are there any homes around there?

A. Yes, sir; there are houses.

Q. And did you arrest anybody that night?  
When I say "that night," I mean June 19th, 1956.

A. June 19th? Yes, we arrested a man.

Q. In the vicinity of the fire hydrant you just described?

A. Well, it depends on what you mean by "vicinity"; right around that intersection.

Q. Right around that intersection?

A. Yes, sir.

Q. You arrested another man that night, did you not?     A. Yes, sir.

Q. While you were doing all this running and searching, you arrested another man in the vicinity—is that [109] right?     A. No, sir.

Q. When did you arrest this other man?

A. After we did the running and searching.

Q. After you found the narcotics in the fire hydrant you arrested another man; is that correct?

A. After we had found the narcotics at the fire hydrant there was an arrest, yes.

Q. On direct examination I thought you told us that no one else was in the vicinity?

A. When, counsel?

Q. During the time you were at the fire hydrant at this intersection at 26th and East John, as you call it.

A. There wasn't anybody. There is a problem of time. I don't know when you mean.

Q. All right; was it shortly after you located



(Testimony of Charles Fahey.)

the narcotics at the fire hydrant you arrested somebody else at 26th and East John?

A. Yes, shortly after that.

Q. Would you say two or three minutes later?

A. No, I would say more than that, counsel.

Q. How long?

A. Oh, let's see: in time, perhaps five minutes; some place in there.

Q. Was the man Sam Blassingame, the defendant in [110] this action, the man you arrested?

A. No, sir.

Q. Somebody other than Sam Blassingame?

A. There might be a confusion. I actually arrested nobody. I was present when Detective Kirschner performed the arrest.

Q. Detective Kirschner performed the arrest?

A. That is correct.

Q. On somebody other than Sam Blassingame?

A. Yes, sir.

Q. And you never had anything to do with the arrest of Sam Blassingame for one and one-half months or two months after this incident; isn't that correct?      A. That is correct.

Q. Although he had been available to you at all times, so far as you are concerned, from June 19, 1956, up until the time the arrest was made in September, 1956; isn't that correct?

A. Yes, sir.

(Whereupon, there was a brief pause.)

Q. Now, directing your attention momentarily

(Testimony of Charles Fahey.)

to the date of May 29, 1956, which pertains to the time that you say Johnny Clark entered some apartment house?      A. Yes, sir.

Q. Do you understand me? [111]

A. Yes; I do.

Q. Now, did you make an arrest that evening?

A. No, sir; not that I recall, anyway.

Q. Did you arrest Sam Blassingame on that date?      A. No, sir.

Q. And, again, did you wait until September 27th, or thereabouts, to arrest Sam Blassingame in connection with that incident?

A. I have actually forgotten the date of Sam's arrest, counsel.

Q. Do you think it was in September?

A. I believe some time in there.

Q. That is when he was arrested?

A. That is it, then.

Q. Not May 29th, 1956, or in June, July or August?

(Whereupon, there was a brief pause.)

A. I didn't realize you asked a question.

Q. I say, not May 29, 1956, or in July, July or August did you make an arrest of Sam Blassingame?      A. No; we didn't arrest him.

Q. Do you know on May 29, 1956, who the other occupants of this apartment were, when Johnny Clark was in that building?

A. I could only see Sam. I don't know who else.

Q. You don't know who else? [112]

(Testimony of Charles Fahey.)

A. No.

Q. Did you see Miss Fitzgerald enter the premises?

A. I saw a woman, and I only assumed it to be Chinky, but I can't testify it was.

Q. Have you ever seen Chinky before; do you know her?      A. Yes; I believe so.

Q. And you say you were able to recognize Sam Blassingame from where you were, but you could not recognize Chinky Johnson?

A. That is very correct.

Q. How far away were you from the entrance to the building or apartment, also described as a duplex; how far away were you in feet?

A. In feet I couldn't tell you. My best guess would be, as I stated, one-half of a downtown city block. That is, a short block out there.

I would say it would be about one-half a block.

Q. And you saw this woman enter the premises, did you?      A. Yes.

Q. And you saw her leave the premises, did you?

A. Yes, sir.

Q. And you saw her twice, and out of the same door you say Sam Blassingame was standing, and you are [113] unable to identify her?

A. I very slightly know her, counsel, and I couldn't identify her. As a matter of fact, I don't believe I knew Chinky prior to that date.

Q. I see. You said once before that time.

A. If you asked me that, it was not my understanding.

(Testimony of Charles Fahey.)

Q. There was a misunderstanding, then.

A. I am very sorry.

Q. Now, let's get this story. You say now you didn't know Chinky prior to this time?

A. I have never talked to Chinky. I have seen her, and which actual times I have seen her, I only remember it once of recent origin, and when you say I don't know her, I don't know what you mean.

Q. So that there is no misunderstanding here, let me ask:

Prior to May 29, 1956—you know what date that represents, don't you?      A. That is correct.

Q. Had you met or talked with Chinky Johnson or Miss Fitzgerald?      A. No, sir.

Q. Had you ever seen her on the street?

A. I have seen her driving her car prior to that time. [114]

Q. You saw her driving her car. Did you know who she was?

A. As I testified, that night I only assumed it was Chinky Johnson, because of the car.

Q. Did you say that Johnny Clark entered the house; you saw that?      A. Yes, sir.

Q. Through the rear entrance?

A. Through the rear entrance.

Q. And then you say you saw a woman enter the house; is that correct?

A. That is correct.

Q. And then you say you saw a woman leave the house?      A. That is correct.

Q. And you can't identify that woman?

(Testimony of Charles Fahey.)

A. The light had not been put on. I couldn't identify that woman.

Q. Did you see that woman drive any type of an automobile?

A. She drove right by us when she came, counsel.

Q. Is that the same automobile you saw prior to May 29, 1956?

A. Now, you have got it.

Q. And you have got it, too?

A. Yes, sir. [115]

Q. Now, there was an Oriental there. Did you see the Oriental about the premises?

A. It looked like a Japanese to me. They turned on the porch light.

Q. You said he was "messing around." What do you mean by that?

A. I don't even know what he was doing—stood around—what he was doing, I couldn't tell.

Q. You couldn't see or couldn't tell?

A. I think in that part of the building there is a garage, and I don't have an entire view of the duplex, counsel.

Q. Is this man a colored man that was messing around?

A. It is possible, but I don't think he was.

Q. Are you sure what he was?

A. No.

Q. Could he have been a white man?

A. No; I don't believe so. I believe he was a Japanese.

Q. You are not positive?

A. No.

Q. It could have been a colored man, or a white man, or a Japanese; you are not sure?

A. I am not positive what he was, would be



(Testimony of Charles Fahey.)

the [115-a] correct answer.

Q. The only person you are positive of seeing that night is Sam Blassingame?

A. The man I knew.

Q. Did anybody else enter the house or leave the house while you were observing the house that night?

A. No, sir; no, sir.

(Whereupon, there was a brief pause.)

Mr. Chavelle: That is all, sir.

### Redirect Examination

By Mr. Roberts:

Q. Mr. Fahey, on direct examination you testified that the fire plug was located at the corner of the intersection of 26th and East Thomas Street.

In answer to questions by counsel for defendant, you changed that to 26th and East John Street.

Now, there is some confusion in my mind as to what your testimony is as to what intersection this was.

A. Counsel, now I am confused in my own mind. 26th and East John is the fire plug, and it is 22nd and Thomas where we parked on the night of May 29th.

If I twisted it around, I certainly——

Q. (Interposing): It is not necessary that you make a final statement right now. If you wish, you may refer to [116] any original notes or records kept by you in the course of your business.

Mr. Chavelle: I object to that. No proper foun-



(Testimony of Charles Fahey.)

dation has been laid to impeach his own witness. He testified already what it was.

The Court: If he wishes to in any way refresh his recollection, he may.

A. Unless I have gotten horribly twisted in names, it is 26th and East John.

Q. (By Mr. Roberts): Why, Mr. Fahey, did you not make an arrest of Sam Blassingame on the evening of June 19, 1956, or at any time shortly thereafter?

A. We anticipated further investigation, would be the main reason. Right in that immediate moment, by the time the evidence was in our hands, the defendant had departed from there, and, as I say, we anticipated further action in the case.

Q. What, if anything, is your policy relative to making an arrest immediately after a buy or receipt of suspected heroin?

Mr. Chavelle: I will object to that, your Honor. The policy is immaterial. There is no issue as to policy in this. [117]

Q. (By Mr. Roberts, continuing): If such a policy exists?

The Court: Do I understand that the purpose of the questions in cross-examination was to indicate delay?

Mr. Chavelle: No; I just asked when the arrest was made, and he said in September.

The Court: You don't contend there was anything unusual about it?

(Testimony of Charles Fahey.)

Mr. Chavelle: No; just bringing it up, when the arrest was made.

Mr. Roberts: I certainly feel counsel will—

The Court: Well, he already stated he will not object. If there is no contention there was nothing unusual about it, I assume it was not material.

Mr. Roberts: Very well. I have no further questions.

The Court: Mr. Fahey, I have one or two questions. I may have—I didn't clearly understand the time that you gave Exhibit 2 for identification to Mr. Ringstrom. I understand you so testified, is that correct, Exhibit No. 2?

The Witness: I gave Exhibit Number 2 to Hugo Ringstrom.

The Court: What time did you deliver that? That is the date I don't have. [118]

The Witness: Number 2 would have been delivered the 21st of June, I believe.

Mr. Roberts: Didn't you testify you kept it over a holiday on the 20th?

The Witness: No; I believe that was the other exhibit.

Mr. Roberts: Very well. I have no further questions.

(Witness excused.)

Mr. Roberts: Your Honor, at this time may I request that we take the mid-afternoon recess?

I have one witness I would like to talk with before I bring him on.

The Court: All right.

Members of the Jury: We will now take the mid-afternoon recess. The Court calls your attention to the admonition given you this morning on the occasion of a recess, and asks that you heed it on this occasion. You may now be excused.

(Whereupon, the jury retired from the courtroom.)

The Court: Court will recess fifteen minutes.

(Whereupon, at 3:03 o'clock p.m., a [119] recess was had in the within-entitled and numbered cause until 3:15 o'clock p.m., January 15, 1957, at which time, counsel and the defendant heretofore noted being present, the following proceedings were had, to wit.)

The Court: You may call the jury.

(Whereupon, the jury was returned to the courtroom.)

The Court: You may be seated.

It is stipulated that the jury and the defendant are present in the courtroom?

Mr. Roberts: So stipulated.

Mr. Chavelle: So stipulated, your Honor.

Mr. Roberts: We will call Johnny Clark. [120]

### JOHNNY CLARK

upon being called as a witness for and on behalf of the plaintiff, and upon being first duly sworn, testified as follows:

The Clerk: Will you state your full name and spell your last name, please?

The Witness: Johnny Clark, C-l-a-r-k (spelling).

(Testimony of Johnny Clark.)

Direct Examination

By Mr. Roberts:

Q. Johnny, where do you live?

A. I live 1522-18th Avenue.

Q. I will ask you if you have ever used narcotic drugs in any form, Johnny?

Mr. Chavelle: I will object to that, your Honor.

The Court: Objection overruled.

Mr. Chavelle: Not an issue.

The Court: Objection overruled.

Q. (By Mr. Roberts, continuing): You may answer the question, Johnny. A. Yes, sir.

Q. Do you use them at the present time?

A. No, sir.

Q. Did you use them in the past?

A. Yes, sir. [121]

Q. For quite a period of time?

A. About three months.

Q. State whether or not you were using narcotics during the months of May and June, 1956, last year? A. Yes, sir.

Q. Inviting your attention to on or about May 29th of 1956, I will ask you if you recall meeting with Seattle Police Department officers and Federal Bureau of Narcotics officers in this city of Seattle?

A. Yes, sir.

Q. Where did you meet them?

A. King Street Tavern—King Street Station.

Q. And where did you go after you left there?

(Testimony of Johnny Clark.)

A. Oh, we went up on a parking lot about 7th or 8th—7th or 8th Avenue.

Q. On Madison Street, or thereabouts?

A. Right up here from this courthouse, up here.

Q. All right; did you stay there, or did you go to some other place?      A. Stayed there.

Q. Did you thereafter go to make a telephone call?      A. No.

Q. On that evening, did you make a telephone call at all?      A. No. [122]

Q. Did you on that evening go to the corner of 19th and Roy Street, up on Capital Hill and make a telephone call?      A. No.

Q. State whether or not you purchased any narcotics that evening?      A. No.

Q. Pardon me?      A. No, sir.

Q. State whether or not you purchased any narcotics with money that was given you by the officers specifically so that you could buy some narcotics with that money on that night?      A. No, sir.

Mr. Roberts: Your Honor, I claim surprise at this time. It is the first indication I have had that this witness may not testify as I have very good reason to believe he would testify earlier in a statement given to Federal Narcotics officers, and I request permission to lead the witness and ask him specific questions relative to a prior statement he has made.

Mr. Kosher: If your Honor please, I object to that on the ground this is an attempt to impeach his own witness without laying the proper founda-



(Testimony of Johnny Clark.)

tion, and I think he should lay the foundation, and that it should be done in [123] the absence of the jury.

The Court: Do you have a sworn statement?

Mr. Roberts: Yes, your Honor, and I certainly will subscribe to any argument on the matter being held outside the presence of the jury.

The Court: All right. Members of the Jury: The Court will excuse you, to consider a matter of law that is not of moment to the jury, on the question of facts, so that you will now be excused.

(Whereupon, the jury retired from the courtroom.)

Mr. Kosher: Your Honor, may I be heard at this time?

The Court: If you wish. Do you wish to make any further reference?

Mr. Roberts: I believe I should make an offer of proof, and if I might have one brief moment to confer with Mr. Fahey.

The Court: All right.

(Whereupon, there was a brief pause.)

Mr. Roberts: If your Honor please, for the record I will read into the record, by way of an offer of proof, a statement given by the Witness Clark to Federal Narcotics agents, specifically Agent Fahey, Charles Fahey, on May 29, 1956, within one hour or so after the time of the [124] alleged buy that has been testified by other witnesses as having taken place on May 29th, 1956.



(Testimony of Johnny Clark.)

The statement reads as follows:

“On this date I was searched by Narcotic Agent L. E. Gooder in the presence of Detectives Sprinkle and Waitt. They looked in my sox and shoes even. I did not have any narcotics on my person. I was supplied with \$25.00 Government advance funds by Agent Gooder. I previously had signed a receipt for Agent Fahey for this money. About 9:00 p.m. I met Detectives Waitt, Sprinkle, Henaby and Kirschner, at the King Street depot as planned and then we went to meet Agent Gooder and Fahey. From there we went to 19th and Roy where we all joined and I made a telephone call from the public phone booth in the presence of Detective Sprinkle. I dialed East 8797 and Sam Blassingame answered. Detective Sprinkle had his ear to the phone also and he could hear the conversation on both ends.

“I asked Sam how long he was going to be around and was it all right for me to come out. He said, ‘Come out.’ This is the time then I was searched and also the officer (Detective Waitt) put some sort of recording device, I guess you call it, on me, and strapped it around me. I don’t know what it is other than what they have told me. [125]

“I went in the Government Ford with Gooder and Sprinkle and Waitt to a spot south of Thomas on 22nd from where you could see ‘Chinkie’s’ house. Detective Sprinkle went with me and I could see him around in the lot.

“I walked to the back door and knocked. Sam came to the back door and he could see through the

(Testimony of Johnny Clark.)

glass and let me in. I gave him the \$25.00 advance funds and told him I wanted one spoon of stuff. He took me in the living room and I sat down and Sam went into the basement. He came back in a little bit and said, 'I can't find the stuff.' He went to the phone and called someone and asked to speak with Chink. He then said, 'Come on home. I can't find the "thing."' These may not be the words he used. I can't recall, but it seems to me it was something like that. It was a short conversation.

"We sat there and talked for awhile and finally I asked him if I couldn't get that 'thing,' and he just nodded his head and said, 'She's coming.' In a little while Chinkie came in. There wasn't a word said and she went in the basement. When she came up she had a prophylactic rubber in her hand and she gave it to Sam saying, "I asked you if you were going to use this tonight before I put it away.' [126]

"He took the rubber and poured out my spoon of stuff right then on the couch where he was sitting. I asked him if it was the same stuff as I'd been getting, and he said, 'Yes, I've got some other but I'm going to fix it up tomorrow.' He used a plain teaspoon to measure with. Chinkie had left as soon as she gave Sam the stuff. The general trend of the conversation had been about the price of heroin in Seattle.

"There was no more conversation. Sam opened the back door for me and I left. I would make a pure guess that I was in the house about twenty or twenty-five minutes. When I went up the walk

(Testimony of Johnny Clark.)

on Thomas, I could see Detective Sprinkle walking up through the grass on my left, and he was with me when I got in the car and rejoined Detectives Waitt and Gooder. It was a clear night and followed one of Seattle's hottest days. The back porch light of the house was on when I left as the neighbors, I guess, were out there.

"When I got in the car Agent Gooder had me mark the paper of heroin for identification with my initials. They then took this machine off of me and we came to the Federal Narcotic office where I make this statement.

"I have known Sam Blassingame since [127] 1945. In 1952 and 1953 when he lived on 15th Street, I bought heroin from him. I started in again about March, 1956, and have been buying regularly from him to this date. I would say that Sam Blassingame is identical with Seattle Police Photograph Number A-2182. I have only known 'Chinkie' since March of this year. She drives about a 1953 Oldsmobile, red and cream car. It has one of those fancy wheels on the rear.

"On one other occasion when I had made arrangements to buy from Sam, Chinkie answered the door and told me the stuff was on the mailbox. I can't read very well, but Mr. Fahey has read this statement over to me, and it is the truth to the best of my knowledge and belief."

Signed by Johnny Clark on both of the two pages.

In addition to that, your Honor, by way of further offer of proof—this morning in response to a

(Testimony of Johnny Clark.)

subpoena, Mr. Clark appeared for trial about five minutes to ten. I only asked him if he was in proper condition to testify and he said he was.

I asked him if there was any change in his testimony from the statement he had previously given to the narcotic officers. He advised me, no, that he would tell the story straight as he had at that [128] time.

During the recess just ten minutes ago I again asked Mr. Clark if he had any problems concerning his testimony. He assured me he had none. He told me he would testify exactly to the truth as he had given to the agents.

For the first time, when I heard his response to the questions, it was apparent to me that he does not so intend to testify and I, therefore, respectfully move the Court that I be permitted to cross-examine this witness on the prior inconsistent testimony.

I will go through and get his story as it is today, and I think I am entitled to cross-examine him in the light of his preliminary statement.

Mr. Kosher: Your Honor, I agree with counsel. If he is surprised, he has a right to impeach his own witness, and I have no reason to doubt it. He undoubtedly is surprised by the testimony of his own witness.

But there is one other thing that must be apparent to the Court, and that is that some affirmative damage must be done to the case. This witness has

(Testimony of Johnny Clark.)

testified to nothing, practically, at this point. He simply says that nothing happened.

The Court: Well, you mean that wouldn't be damaging to their case?

Mr. Kosher: Now, what he wants to do—the purpose of his impeachment will be to show that [129] this witness is an untruthful witness and the danger always lays in the jury hearing this statement and taking it for the truth of what was said, and that isn't the purpose for which he is being impeached now.

The Court: I don't think that is sufficient ground to not permit him the examination. The document doesn't necessarily go into evidence at all.

Mr. Kosher: No; but I think this jury should know now——

The Court (Interposing): And I don't think—there are certain parts of it that I don't think he should be interrogated about.

Mr. Kosher: The point I am making is this——

The Court: Namely, purchases made, and previous buys.

Mr. Roberts: That is right, your Honor. I agree.

Mr. Kosher: Then what will happen is quite apparent. This witness will be confronted with these statements that he supposedly made to show that he made prior inconsistent statements, the purpose being to show it is not likely that this witness upon the witness stand is telling the truth.

The Court: That is correct.



(Testimony of Johnny Clark.)

Mr. Kosher: But the danger, of course, lies [130] in——

The Court (Interposing): The Government, of course, is bound to call this witness if he is available. The Government can't pass a witness available to them and not call him, and on the showing made here, it is that he would have reasonable cause to believe that he signed such a statement, and the Government, having the burden of producing the witness, when one is available, and certainly having knowledge that would be material here under the theory and under the facts as they have advanced, I certainly think, for what interest or weight it may have with the jury, I think it should be brought out.

Mr. Kosher: I think that now he is going to cross-examine his own witness for the purpose of showing that the witness upon the witness stand is just not a truthful witness, but this jury should not be permitted, I don't believe, to take the out-of-Court statements he made and assume that they prove certain facts in this case, and I think if the Court is going to permit him to cross-examine this witness at this point that the jury should be made to understand the purpose of it, because the danger lies in the fact that this jury may accept these out-of-Court statements as some proof in the matter.

The Court: The Court will give a proper instruction at the proper time. [131]

Mr. Roberts: I believe the instruction should



(Testimony of Johnny Clark.)

relate to the credibility of the witness and what weight the jury may give to it.

The Court: The only questions that he may cross-examine him on are questions which would be material to the issues in this case. They are the only ones that you may refer to.

Mr. Roberts: Yes, your Honor.

The Court: And, of course, he should be given opportunity to see the statement and to read it.

Mr. Kosher: If your Honor please, I think it is only fair to this witness that somebody instruct him that he has certain rights here.

Mr. Roberts: I believe Mr. Chavelle is his lawyer.

Mr. Chavelle: Not in this case I am not his lawyer.

Mr. Roberts: In a murder case, isn't that true?

Mr. Kosher: If this man made a statement to the narcotic officers, I think he should, at least, know he has a right to invoke the Fifth Amendment if he wants to.

In other words, it is a crime for this man to have made a false statement to the narcotic agents, if he is now telling the truth upon the witness [132] stand.

The Court: Well, I can advise the defendant—I mean the witness, Mr. Clark—that it is the constitutional right of any individual to not make a statement which will serve to incriminate him—which will subject you to prosecution.

Mr. Kosher: Do you understand that, Mr. Clark? Do you understand what the Court just told you?

(Testimony of Johnny Clark.)

The Witness: No, sir.

Mr. Roberts: I believe, your Honor, that it might be pertinent to explain to the witness that he is under no compulsion to answer any question. He has a right and he, himself, should advise the Court in response to any question that he desires to invoke his privilege under the Fifth Amendment of the Constitution, not to answer that question, because it may tend to incriminate him in a Federal crime.

The Court: Well, Mr. Clark, you have been called as a witness. You understand that?

The Witness: Yes, sir.

The Court: Now, no person is required to answer a question put to them on the witness stand which question would serve to subject them to—or might lead to their incrimination, or being charged with a crime.

In other words, you are not required to make a statement which could be used as evidence against you [133] in the prosecution—in a prosecution for an offense.

It is an offense to falsely testify. It is an offense to make a false statement to a person such as Mr. Fahey in connection with a matter that is material to his work; that is, within the nature of his duties.

In other words, if you make a false statement in regard to narcotics to a narcotic officer, that is an offense.

Now, you are not required to testify or to answer questions that may be put to you by Mr. Roberts

(Testimony of Johnny Clark.)

if they would tend to incriminate you or tend to subject you to prosecution for an offense.

Do you understand that?

The Witness: Yes, sir.

Mr. Roberts: I think it should be made clear to him, also, your Honor, that I may ask of him some questions which, in my opinion, may not incriminate him, but the decision is with the witness himself as to the given question asked.

The Court: I think I have sufficiently covered it.

Mr. Chavelle: Does he understand it now?

The Court: He says he does. I don't know the man.

Mr. Kosher: I don't, either.

Mr. Chavelle: I represented him in a [134] murder case down in Justice Court.

The Court: Do you know him?

Mr. Chavelle: Yes.

Mr. Roberts: Do you feel he understands the Court's instructions, Mr. Chavelle?

Mr. Chavelle: I don't think he does understand.

The Court: Do you want to ask him some questions here then?

Mr. Chavelle: Do you understand what the Court just told you, and what Mr. Roberts explained to you, that you have certain rights under the Federal Constitution, and if there is any question propounded to you or asked of you that you feel incriminates yourself or subjects yourself to the penalty of the law, that you have a right to refuse to answer that?

(Testimony of Johnny Clark.)

The Witness: Yes, sir.

Mr. Chavelle: Do you understand that?

The Witness: Yes, sir.

Mr. Chavelle: Is that clear in your mind?

The Witness: Yes, sir.

Mr. Chavelle: And you understand that is as to each question that might be propounded to you—if there is something you feel that would involve you or subject you to the penalty of the law, you have a right to protection under the Fifth Amendment to the Constitution to say, [135] “I refuse to answer any question on the ground it might incriminate me and open me to prosecution”?

The Witness: Yes, sir.

Mr. Chavelle: Do you understand that?

The Witness: Yes, sir.

Mr. Chavelle: Thoroughly?

The Witness: Yes, sir.

Mr. Roberts: You understand, Johnny, when a question is asked of you, if you think it will incriminate you, you must speak up and say, “I refuse to answer that question on the ground of the Fifth Amendment, because it may tend to incriminate me”?

The Witness: Yes, sir.

Mr. Roberts: Do you understand that?

The Witness: Yes, sir.

Mr. Chavelle: Do you understand that you must say, as to each question, whether you feel it will incriminate you; do you understand that?

The Witness: Yes, sir.

(Testimony of Johnny Clark.)

The Court: Do you think he understands it, Mr. Chavelle?

Mr. Chavelle: Yes; I think he does.

The Court: Mr. Clark, do you think you do?

The Witness: Yes, sir.

The Court: That doesn't mean that any [136] question that you should—that all questions will incriminate you. There may be many questions that wouldn't.

Of course, you are to claim this privilege if you choose to and you don't have to claim privilege, but it is your right if you choose to. It applies to questions which may have a tendency to incriminate.

Now, that may be a little difficult for a layman to understand at times, but, after all, only the person that claims it can determine that.

The Witness: Yes, sir.

The Court: I don't know how qualified he is to make those claims. I don't know what his condition is. If counsel thinks he should be further informed——

Mr. Chavelle (Interposing): Well, we will try it as we go along, and if it seems he can't understand——

Mr. Roberts (Interposing): I would rely, your Honor, more on Mr. Chavelle's opinion, inasmuch as it appears, your Honor, he has represented and does not represent the witness in another very substantial criminal charge pending against him in State Court.

I am assuming Mr. Chavelle has discussed that



(Testimony of Johnny Clark.)

matter with Mr. Clark at some length and has formed his own opinion as to his client's ability to understand his rights. [137]

Mr. Chavelle: Well, as far as the murder case was concerned, it was a preliminary hearing, and Mr. Clark has never been on the witness stand so far as I know.

Mr. Roberts: I assume you talked to him about the case?

Mr. Chavelle: Yes.

Mr. Roberts: You did?

Mr. Chavelle: Yes.

The Court: Are you ready to proceed? I think the Government is entitled to claim surprise.

Mr. Chavelle: I think it should also be settled what parts he will refer to.

Mr. Roberts: I may advise the Court that the only part of the statement I intend to refer to is the statement of Mr. Clark; first of all, I will ask him if he made a statement May 29th.

The Court: Before you go into that—can you read?

The Witness: Not so good.

Mr. Roberts: May I ask you, Johnny, if your statement was read to you by anyone in the Narcotics office?

The Witness: My statement? I haven't made no statement.

Mr. Roberts: Pardon me, sir? [138]

The Witness: I haven't made no statement.

(Testimony of Johnny Clark.)

Mr. Roberts: Was a statement read to you today?

The Witness: Oh, an officer read a paper to me.

Mr. Roberts: And didn't he give you the paper and say, "Johnny, you had better look this over"?

The Witness: That is right.

Mr. Roberts: And that was just today, wasn't it?

The Witness: Yes, sir.

Mr. Roberts: Well, I will hand you——

The Court (Interposing): Is there a signature there?

Mr. Roberts: Yes.

The Court: Have you seen this?

Mr. Kosher: No, we haven't.

Mr. Roberts: I believe it should be marked, if your Honor please.

The Court: Yes; I think so. I see no reason why counsel shouldn't look at it now, do you?

Mr. Roberts: None whatever, your Honor.

The Clerk: Plaintiff's Exhibit No. 3 for identification.

(Plaintiff's Exhibit No. 3 marked for [139] identification.)

Mr. Kosher: Mr. Clark, did you sign this exhibit?

The Court: He hasn't seen it. Just a minute. Look it over, first.

(Whereupon, there was a brief pause.)

The Court: Mr. Roberts, do you want some more time?

(Testimony of Johnny Clark.)

Mr. Roberts: I am prepared to go ahead, if your Honor please.

The Court: Well, counsel have looked this over. Mr. Kosher wanted to ask Mr. Clark if this is his signature. It seems to me that that is a matter to be asked before the jury. I don't think we should go into that now, unless counsel has some other view of it.

Mr. Roberts: Has Mr. Clark seen this?

The Court: I don't believe he has.

Mr. Roberts: If not, I think we should do it in the presence of the jury.

The Court: I think it should be before the jury.

Mr. Chavelle: Yes.

The Court: Are there any other questions you anticipate? Certainly that part of the statement that refers to purchases at other times has no bearing.

Mr. Roberts: I have no intention of going [140] into that.

The Court: All right, you may call the jury

(Whereupon, the jury was returned to the courtroom.)

The Court: You may be seated.

It is stipulated that the jury and the defendant are present in the courtroom?

Mr. Chavelle: So stipulated, your Honor.

Mr. Roberts: So stipulated, your Honor.

The Court: You may proceed under your claim of surprise.

Mr. Roberts: Thank you, your Honor.

(Testimony of Johnny Clark.)

Q. (By Mr. Roberts): Johnny, you told us on the evening of May 29, 1956, you met with police officers at the King Street station and went with them to 7th or 8th or 9th and Madison, a vacant lot, and met some other officers; am I correct to that point?

A. Yes.

The Court: Keep your voice up, Mr. Clark.

A. (Continuing): Yes.

Q. (By Mr. Roberts): And I asked you if it wasn't a fact you went from that point on down to the corner of 19th and Roy on [141] Capitol Hill to make a telephone call. Did you so do?

A. No, sir.

Q. What did you do at this vacant lot on Madison Street?

A. Well, I went up there with some officers and we met some more officers up there in the car lot, and they was asking me about trying to make a buy.

Mr. Chavelle: I will object to that as hearsay, your Honor; a statement made not in the presence of the defendant, Blassingame, in conversations between Mr. Clark and the officers.

The Court: This is not a conversation up to this point. Go ahead.

Q. (By Mr. Roberts): What did you do as a result of that meeting?

A. They was asking me about trying to make a buy of some narcotics for them.

Q. Did they mention anyone in particular?

A. Not at that particular time.

Q. Well, what did you do then?

(Testimony of Johnny Clark.)

A. So they give me a phone number to call them back later, after I think of it. So, about a day or so later I run into the officers again.

Q. Just a moment. I would like you to confine—tell us what you did the evening of May 29th. [142]

They gave you a phone number; then what did you do? A. I left.

Q. You didn't do anything more with the officers that night? A. No.

Q. Isn't it a fact you went with the officers down to 19th and Roy and made a telephone call?

A. No.

Q. Didn't you thereafter go down to 23rd and Thomas and go up to the back door of a duplex?

A. No, sir.

Q. Didn't you thereafter go on into that duplex and have a conversation with Sam Blassingame?

A. No, sir.

Q. Speak up, Johnny.

A. I didn't see Mr. Blassingame.

Q. You didn't see him? A. No, sir.

Q. Do you know Sam? A. Yes, sir.

Q. Did you know him on May 29th?

A. I have been knowing him since about '43 or '4.

Q. Johnny, what kind of a relationship do you have with him? [143]

A. Oh, just know him when I see him.

Q. You just know him when you see him; do you have any business dealings with him?

A. No, sir.



(Testimony of Johnny Clark.)

Q. What business is he in?

A. I don't know what business he is in.

Q. You don't know of any business that he is in?

A. No, sir.

Q. It is your testimony that you did not go to Chinkie Johnson's apartment, 23rd and Thomas, on May 29th; is that right?      A. That is right.

Q. And you didn't buy 36 grains of heroin, or a spoon of heroin, that night?      A. No, sir.

Q. Isn't it a fact that on the evening of May 29th you were in the office of the Federal Bureau of Narcotics, in this very courthouse building, and that you made a written statement to them about the things you had done that very night concerning buying narcotics?

You are under oath, Johnny.

A. Well, I refuse to answer that.

Q. Pardon me?

A. I refuse to answer that on the grounds of the Fifth Amendment. [144]

Q. What is your specific reason for refusing to answer that question?

A. It would be incriminating.

Mr. Kosher: Just a minute.

The Court: He has answered it sufficiently.

Mr. Roberts: I think the full answer would be——

The Court (Interposing): He says it would be incriminating. It might well be.

Q. (By Mr. Roberts): I hand you, Johnny, a document marked as Plaintiff's Exhibit No. 3 for

(Testimony of Johnny Clark.)

identification. I ask you to examine this piece of paper. There are two sheets. Take it in your hand. Look at it very closely. Particularly look at the bottom of the page. Do you observe any pen and ink writing there?      A. Yes, sir.

Q. What does that writing say?

A. "Johnny Clark."

Q. Is that your signature?

A. Yes, sir; that is my signature.

Q. Look at page two. Is there any writing at the bottom of that page?      A. The same writing.

Q. What is that writing? [145]

A. That is my name, Johnny Clark.

Q. Is it your writing?

A. Yes, sir; that is my signature.

Q. Did you write that down there?

A. Yes, sir.

Q. Look at the first page. What date does this document bear at the top?

A. That says May 29, 1956.

Q. What city?      A. Seattle, Washington.

Q. And it says by whom?

Mr. Kosher: I object to him referring to matters in that document.

A. This says Johnny Clark.

Q. (By Mr. Roberts): All right, Johnny; did you make this statement?

A. I ain't done no writing or nothing. I sign my name to these papers. What was on them, I don't know. I don't know what somebody might put on there.

(Testimony of Johnny Clark.)

Q. You don't know what was on them? Did anybody read that statement to you before you signed it?

A. I read it—the man read it today. This is the first time my seeing it knowing what was on it from what he was reading to me today. I don't know what was on it before. [146]

Q. You are charged with murder in the State Court, are you not?      A. That is right.

Mr. Chavelle: I object.

Mr. Kosher: I object.

The Court: Objection sustained.

Mr. Kosher: And I move for a mistrial at this time.

The Court: Members of the jury:

The Court sustained the objection to the question and you should disregard the answer made, if any, and also you are not to give any effect or draw any inferences from the question and the fact that it was put.

Q. (By Mr. Roberts): Did you sign this statement today when it was shown to you, Johnny?

A. No, sir.

Q. You didn't sign it today?      A. No, sir.

Q. Well, could you have signed it on May 29, 1956, the date that it bears?

A. I may have—could have—signed it then. I don't know what day I signed it.

Q. That was the day you met with all the police officers and the narcotic officers, isn't that [147] right?

(Testimony of Johnny Clark.)

Johnny, do you believe in God?

A. I met those officers at night.

Q. Johnny, do you believe in God Almighty?

A. Yes.

Mr. Kosher: I object to that on the ground it is immaterial.

Mr. Roberts: I believe this man is trying to tell the truth, and I would like to interrogate him along this line.

Q. (By Mr. Roberts): Are you a religious man?

A. Yes, sir.

Q. Do you believe that there is a God in Heaven?

A. Yes, sir.

Q. Now, you are under oath on this witness stand? A. That is right.

Q. Do you know what an oath is?

A. Yes, sir.

Q. Do you know that an oath is a solemn calling upon God Almighty to witness the truth—

A. (Interposing): That is right.

Q. (Continuing): —of answers to the questions, of questions put to you? A. Sure.

Q. Do you want to tell the truth, Johnny? [148]  
On May 29th, did you make a telephone call?

A. No, sir.

Q. Did you go to Sam's apartment?

A. No, sir.

Q. Johnny, in this statement, which is over your signature, it says that on May 29th—

Mr. Kosher (Interposing): May the record show that we object to this?

(Testimony of Johnny Clark.)

The Court: I beg pardon?

Mr. Kosher: May the record show that the defendant Blassingame objects to any reading of this statement on the ground it is an attempt to impeach this witness without a proper foundation being laid for it?

The Court: The record may so show.

Q. (By Mr. Roberts): ———Johnny, in this statement, which is over your signature, the following is said:

“On this date \* \* \*” May 29, 1956, “\* \* \* I was searched by Narcotic Agent L. E. Gooder in the presence of Detectives Sprinkle and Waitt. They looked in my sox and shoes even. I did not have any narcotics on my person.”

Is that true? Did they do that on May 29, 1956?

A. I refuse to answer that.

Q. On the ground it may tend to incriminate you, [149] is that correct? A. Yes, sir.

Q. You feel free to make that reply.

“I was supplied with \$25.00 Government advance funds by Agent Gooder. I previously had signed a receipt for Agent Fahey for this money.”

Is that a true statement?

A. I refuse to answer to that on the grounds.

Q. “About 9:00 p.m. I met Detectives Waitt, Sprinkle, Henaby, and Kirschner at the King Street Depot as planned and then we went to the Agents Gooder and Fahey. From there we went to 19th and Roy where we all joined and I made a telephone



(Testimony of Johnny Clark.)

call from the public phone booth in the presence of Detective Sprinkle.”

Is that a true statement?

A. I refuse to answer.

Q. On the grounds of the Fifth Amendment?

A. On the ground of the Fifth Amendment.

Mr. Koshier: And may the record disclose our running objection, your Honor, so that I won't have to object to every question he puts?

The Court: Yes. I think there are some questions there that may not be appropriate. Does the Government have any objection to letting a continuing objection run? [150]

(Whereupon, there was a brief pause.)

Q. (By Mr. Roberts): Did you say:

“I dialed EAst 8797 and Sam Blassingame answered. Detective Sprinkle had his ear to the phone also and he could hear the conversation on both ends.”

Mr. Chavelle: Just a minute. I thought you proposed a question to counsel?

The Court: Yes. Do you have any objection to having a running objection?

Mr. Roberts: Yes; I will stipulate to that, your Honor.

Mr. Chavelle: Very well.

Mr. Roberts: And I will further advise Court and counsel I will not go into any matters not pertinent to this particular case.

Q. (By Mr. Roberts, continuing): What was

(Testimony of Johnny Clark.)

your answer to that last question, Johnny? Do you refuse to answer that also?           A. Yes, sir.

Q. Did you say:

“I asked Sam how long he was going to be around, and was it all right for me to come out.”

And did you further say:

“He said, ‘Come on.’ ” [151]

A. I refuse to answer that.

Q. Did you also say:

“This is the time then I was searched and also the officers put some sort of recording device, I guess you call it, on me, and strapped it around me. I don’t know what it is other than what they have told me. I went in the Government car with Gooder and Sprinkle and Waitt to a spot south of Thomas on 22nd from where you can see ‘Chinkie’s’ house.”

Did you also say that?

The Court: The question is, did that happen?

Q. (By Mr. Roberts, continuing): Did that happen?           A. No, sir.

Q. Pardon me?           A. No, sir.

Q. Do you refuse to answer that?

The Court: He answered it.

Mr. Roberts: Pardon me.

Q. (By Mr. Roberts, continuing): Did you also tell the officers:

“Detective Sprinkle went with me and I could see him around in the lot,” as you approached [152] Chinkie’s apartment?           A. No, sir.

Q. Did you also tell the officers that you walked

(Testimony of Johnny Clark.)

to the back door and knocked at Chinkie's apartment?      A. No.

The Court: I think you had better put that—you had better ask whether that happened.

Mr. Roberts: Pardon me?

The Court: You had better change those questions. Did it happen? I think he said he made no statement.

Mr. Roberts: All right.

Mr. Chavelle: I think what counsel is doing is asking, did he make the statement, and he is answering that. It is not whether it actually happened. Did these things happen that are contained in the statement?

Q. (By Mr. Roberts): Isn't it a fact, Johnny, that you knocked on the door, and that Sam opened the door and let you in, and that you gave him \$25.00 in money that the agent had given you on May 29th?      A. No, sir.

Q. Pardon me?      A. No, sir.

Q. Didn't you also tell him at that time that you [153] wanted a spoon of stuff?

A. No, sir; I never had no conversation with that man about narcotics.

Q. Isn't it a fact that at that time he took you into the living room and said he couldn't find his stuff, and then he went to the phone and called someone and asked to speak to "Chink," and then he said, "Come on home, I can't find the thing," to the party he was talking to on the phone?

A. No, sir.

(Testimony of Johnny Clark.)

Q. And didn't you just sit around the apartment with Sam "awhile and finally I asked him \* \* \*" didn't you ask him if you couldn't get that thing, and he just nodded his head and said, "She is coming"?

Didn't that take place?

A. I never saw Sam that day.

Q. Isn't it a fact a little while later Chinkie came in and there wasn't a word said, that she just went down to the basement and came back carrying a rubber package which she gave to Sam, and she said, I think, "I asked you if you were going to use this stuff tonight before I put it away"; didn't that take place?

A. No, sir.

Q. Didn't Sam take that rubber package and pour out a spoon for you right there on the couch where he was [154] sitting?

A. I never got no narcotics from that man at no time.

Q. Didn't you ask him if this was the same stuff you had been——

Mr. Roberts: Strike that. I believe that is material, your Honor. I will rephrase the question.

Q. (By Mr. Roberts, continuing): Didn't you also ask Sam Blassingame at the time he was pouring this spoon for you if this was the same stuff you had been getting?

Mr. Chavelle: I object to that, your Honor, and ask for a mistrial. Counsel was admonished to not go into that at all, and he is referring to some other

(Testimony of Johnny Clark.)

transaction, or other stuff, that this man is alleged to have obtained from the defendant.

We have a stipulation it will not be referred to and it has been referred to. It is prejudicial to the defendant's case.

Mr. Roberts: This is a direct quote of a conversation that actually took place at the time of this sale.

Mr. Chavelle: We agreed those things could not be gone into, as to what previously happened.

Mr. Roberts: It has a direct bearing on the conditions of a buyer and seller at the time of [155] this transaction.

The Court: I think rather than—it may be but out of an abundance of caution I will sustain an objection to the question.

Mr. Roberts: Very well, your Honor.

Q. (Continuing): And isn't it a fact that after this you left the apartment and rejoined Detective Sprinkle and went and met with Sprinkle and Gooder and delivered this parcel of heroin which you just purchased from Sam? Didn't you do that on the evening of May 29th?           A. No, sir.

Mr. Roberts: I have no further questions.

The Court: Before you proceed with cross-examination:

Members of the Jury:

The United States Attorney has just been examining this witness with respect to certain matters contained in a document that has been marked as Exhibit No. 3. The Court wants to advise you as to the purpose of that questioning.



(Testimony of Johnny Clark.)

It has appeared in connection with this witness that the Government has been surprised, and that they anticipated other—that this witness would testify otherwise than he has indicated on the stand.

The Court has allowed the Government to [156] examine this witness by the use of what are known as leading questions; in other words, permitted him to be cross-examined.

These questions that have now been put here, which have been put after referring to this exhibit, are not to be construed as evidence of the facts contained in those questions. Those questions were put because they have some bearing upon the credibility of this witness, and while the witness has indicated his signature appears on that document, you are not to construe the questions as put to him from that document as being evidence in and of themselves insofar as this witness is concerned. The only purpose is to bring out matters that may have a bearing so far as the jury is concerned on whether or not they are going to believe this witness.

Mr. Roberts, does that, in substance, cover the purpose?

Mr. Roberts: I believe it does, your Honor.

The Court: Mr. Chavelle and Mr. Kosher?

Mr. Chavelle: Yes.

Mr. Kosher: Yes.

Mr. Chavelle: We have no cross-examination.

Mr. Kosher: I have none.

The Court: That is all, Mr. Clark.

(Witness excused.)

Mr. Roberts: We will call Mr. Du Puis. [157]

CHARLES F. DU PUIS

upon being called as a witness for and on behalf of the plaintiff, and upon being first duly sworn, testified as follows:

Direct Examination

By Mr. Roberts:

Q. Please state your full name and your occupation?

A. Charles F. Du Puis, D-u P-u-i-s (spelling), Narcotic Agent attached to the Treasury Department, stationed at Seattle, Washington.

Q. Mr. Du Puis, were you so stationed here in Seattle during the months of May and June, 1956?

A. I was.

Q. Inviting your attention to on or about June 19, 1956, I will ask you if you had occasion to meet a man by the name of Johnny Clark?

A. I did.

Q. Will you describe the circumstances surrounding that meeting?

A. I met Mr. Clark with Mr. Fahey, Mr. Sprinkle, Mr. Henaby and Mr. Kirschner here at 7th and Madison in a parking lot.

Q. And as a result of that meeting, what did you do?

A. Mr. Kirschner and Mr. Fahey and I [158] drove to the vicinity of 26th and East Thomas here in Seattle, Washington.

Q. And what——

(Testimony of Charles F. Du Puis.)

Mr. Chavelle (Interposing): What was the address? I am sorry.

The Witness: 26th and East Thomas, Seattle, Washington.

Q. (By Mr. Roberts, continuing): Would you describe the intersection at 26th and East Thomas?

A. 26th going north is a dead-end street. East Thomas going west is a dead-end street.

Q. As you look west from East Thomas, what do you see?

A. You see some concrete stairs running up to East Madison Street.

Q. And what is the degree of slope, if any, on the stairs?

A. Oh, it is pretty steep. I would say 35 degrees or thereabouts.

Q. What did you observe by way of vegetation on that hill?

A. On the left-hand side of 26th, as you are going north, there is a steep bank with bushes and small trees on it.

Q. And as you look east from the center of the intersection [159] down Thomas, what do you observe, generally?

A. A residential district on both sides of the street.

Q. Is there a hill or is it level, or what is the general situation?

A. It slopes east and down eastward.

Q. What did you do when you arrived at that intersection?

(Testimony of Charles F. Du Puis.)

A. Mr. Fahey and Mr. Kirschner left the automobile and searched around the fire plug at 26th and East Thomas, and I backed my car part way down the block.

Mr. Chavelle: I will object to this observation, as to what he was told. He parked his car and backed away.

Q. (By Mr. Roberts): I want you to only testify as to what you, yourself, did or observed at that time.

Mr. Chavelle: He placed himself in the car and was backing away. Now he is testifying to what was told to him.

The Court: The objection is overruled.

A. I got out of the car and rejoined Kirschner and Fahey, and I assisted in searching around the plug, and then I got—we got back in the car and turned right, on East Thomas, part way down the block, and I turned my lights out. [160]

Q. (By Mr. Roberts): Approximately what time of the day was this, Mr. Du Puis?

A. Right around 10:00 p.m. in the evening.

Q. After you turned your lights out, what happened?

A. We had a conversation, the three of us, and I observed someone in the rear view mirror of my car coming down the steps, and Kirschner—I drew the attention of that to Kirschner and Fahey, and they left the car. So then I coasted down to 27th and East Thomas with my lights out.

Q. What did you do?

(Testimony of Charles F. Du Puis.)

A. I turned around at the intersection there. I had to back up once, and I came back up the hill, and I turned my lights on, and as I came up the hill my lights flashed on a man wearing a light top-coat. He was on the first landing of the steps running towards East Madison.

Q. Did you recognize that man as anyone you had seen prior to that time?      A. Yes; I did.

Q. Who was he?      A. Mr. Blassingame.

Q. Did you know Sam Blassingame on the evening of June 19th?

A. I have known him for a long time.

Q. About how long? [161]

A. About five or six years.

Q. Have you had occasion to see him many times in the past?

A. Yes; I have seen him several times.

Q. Is there any possibility you could be mistaken in your identification of him at that time?

A. No, sir.

Q. After seeing him on the steps, what did you do?

A. As I was saying, I came up the—drove up west on East Thomas. Mr. Kirschner and Mr. Fahey had gone by the fireplug.

As I came up, Mr. Kirschner called to me and I left the vicinity.

Q. And then what did you do?

A. I drove down south three or four blocks, and east a block or two, and waited a few minutes, and then I came back to the fireplug.



(Testimony of Charles F. Du Puis.)

Q. Then what did you do?

A. I got out of the car. Mr. Fahey took me over to the fireplug. He flashed his flashlight at the base of it, and there was a rubber container sitting at the base of the fireplug with some white powder in it.

Q. And then what happened?

A. Mr. Fahey picked up the container and we initialed it, and came down to the Seattle police station, Narcotics [162] Bureau, and Mr. Fahey, I believe, got the powder to dust the package for fingerprints.

Q. At this point, Mr. Du Puis, I will ask you to examine the contents of Plaintiff's Exhibit Number two, and state if you recognize it?

A. I do.

Q. What is it?

A. This is the package Mr. Fahey picked up from the fireplug at 26th and East Thomas on the night of June 19th, 1956, at approximately 10:10 p.m.

Q. How are you able to be definite about that statement?

A. It has my initials, "C.D.," on the rubber container.

Q. Will you examine the envelope itself and tell us whether or not your handwriting appears thereon?

A. My handwriting does appear thereon.

Q. Do you recall when you put your handwriting on it?

(Testimony of Charles F. Du Puis.)

A. The 19th of June, 1956, at 11:45 p.m.

Q. And when did you last see this particular exhibit?

Mr. Roberts: Strike that. I will ask another question.

Q. (By Mr. Roberts, continuing): In whose custody, if you know, was this exhibit retained after it was picked up from the fireplug? [163]

A. As far as I know Mr. Fahey had it.

Mr. Roberts: I have no further questions.

#### Cross-Examination

By Mr. Kosher:

Q. Now, do I understand that when you got to this area, where there was this stairway, that you say you noticed a man upon the landing or one of the landings there; is that correct?

A. I didn't say that, counsel.

Q. Where did you first notice this man coming down the stairway?

A. After the fireplug had been searched, I was parked on East Thomas facing east, and I noticed him in the rear-view mirror of the car.

Q. How far away from—how far away was the car from where this man was you claim you saw and recognized?

A. Let's not confuse the question, please, sir. Are you asking when I saw him, and could identify him, or when I saw the man the first time?

Q. When you first saw the man through your

(Testimony of Charles F. Du Puis.)

rear-view mirror, how far away from this man were you?

A. I was about three-quarters of a block down the street and part of the stairway. [164]

Q. In other words, you looked through your rear-view mirror from three-quarters of a block away, and part of the stairway, and you saw a man, is that right?

A. I saw a man; that is right.

Q. All right. Is it possible there were some other people around there at that time and you wouldn't see them?

A. That is quite correct.

Q. There could be a lot of people at the base of the landing and you wouldn't have seen them, isn't that right?

A. No.

Q. Why isn't that possible?

A. Because I just searched the fireplug and when we had driven east on Thomas it couldn't have been a matter of ten seconds, and the men were getting out of the car, and I noticed a person coming down.

Q. Is it a wooded area right around this stairway?

A. That is right.

Q. Is it possible there could be a person or persons concealed in this wooded area?

A. I wouldn't know.

Q. It is possible, is it not?

A. That is possible; sure.

Q. All right. Now, this fire hydrant that you have reference to, how close is it to the foot of the stairway that you have described? [165]

(Testimony of Charles F. Du Puis.)

A. Well, it is—again, it is purely an estimate—it is diagonally across the corner of the intersection.

Q. In other words, there is the sidewalk at the foot of the stairway, and then there is the street; isn't that right?

You have to cross the street diagonally?

A. That is correct.

Q. And across the street, whatever length that is, there is a fire hydrant; isn't that correct?

A. That is correct.

Q. Was it dark when you went out there?

A. It was night, 10:00 p.m.

Q. Ten o'clock at night; were there any street lights there?

A. Yes, there is three bright lights on East Madison.

Q. On East Madison?           A. Yes.

Q. And where did you say the hydrant was—what street?           A. 26th and East Thomas.

Q. How many street lights are there on 26th and East Thomas?

A. There is one that I know of, as I recall.

Q. Where is that at?

A. It is an overhead light, but I don't even recall [166] if that was burning or not.

Q. It is possible it could not have been burning?

A. That is quite possible, yes.

Mr. Kosher: I think that is all.

Q. (By Mr. Kosher): Now, did you see another man arrested in that area some time after ten o'clock?

(Testimony of Charles F. Du Puis.)

A. I didn't see a man arrested, but he was arrested and in custody when I returned.

Q. Who was that man?

A. I can't recall his name.

Q. Was it Sam Blassingame? A. No.

Q. Was it a colored man? A. Yes, it was.

Q. Did you see that man when you were looking through your rear-view mirror? A. No.

Q. From the time you looked through your rear-view mirror and the time you saw this man in custody, how much time elapsed?

A. Possibly ten minutes.

Q. And you were in that immediate area at all times, were you, during that ten-minute period?

A. No, I wasn't. [167]

Q. Well, when were you outside of the view of the stairway in that ten-minute period?

A. I was out of view of the stairway while I was making a U-turn with the car, possibly ten or fifteen seconds, and after I drove away after Sam left the area, I was gone five or ten minutes. So, ten minutes, at the maximum, I was out of view and out of the vicinity of the fire plug.

Q. But the man had already been arrested when you returned, is that correct?

A. That is correct.

Q. And you don't know how long he had been arrested by the time you got back?

A. I have no idea, no.

(Whereupon, there was a brief pause.)



Mr. Kosher: That is all.

Mr. Roberts: I have no further questions.

The Court: That is all, Mr. Du Puis.

(Witness excused.)

Mr. Roberts: We will call Mr. Kirschner. [168]

C. F. KIRSCHNER

upon being called as a witness for and on behalf of the plaintiff, and upon being first duly sworn, testified as follows:

The Clerk: Will you state your full name and spell your last name, please?

The Witness: C. F. Kirschner, K-i-r-s-c-h-n-e-r (spelling).

Direct Examination

By Mr. Roberts:

Q. What is your occupation, Mr. Kirschner?

A. Detective, Narcotics Detail, Seattle Police Department.

Q. How long have you been so employed?

A. Sixteen years with the Police Department, twelve years in the Detective Division.

Q. Were you so employed during the months of May and June, 1956?           A. Yes, I was.

Q. Directing your attention to on or about May 29, 1956, state whether or not you met Johnny Clark on or about that date?

A. Yes, on that particular night I met him at the King Street station. [169]

(Testimony of C. F. Kirschner.)

Q. Approximately what time of the evening was it?  
A. Nine o'clock.

Q. Who was with you, other than Clark?

A. On that night it was, I believe, Detective Henaby and myself that met him.

Q. What did you do after meeting him?

A. We went up to 7th and Madison and met the Federal Agents.

Q. Who was present, if you recall?

A. As I recall, it was Mr. Fahey and Mr. Gooder, and then Waitt, Sprinkle, Henaby and myself.

Q. And what did you do?

A. We went to 19th and Roy from there.

Q. What happened there, Mr. Kirschner?

A. At 19th and Roy, Johnny Clark made a phone call. Detective Sprinkle listened on the phone. And from there we proceeded to depart from that place.

Q. All right. Did you depart that area?

A. Yes.

Q. What did you do?

A. We went with Mr. Fahey, and it was Mr. Fahey and Mr. Henaby and myself, went to 22nd and Thomas, or, it would be the northwest corner.

Q. What did you do there?

A. We sat there until we viewed Mr. Clark and Mr. [170] Waitt and Sprinkle drive down one-half block below us.

Q. They were in another automobile?

A. They were in another automobile.

Q. What happened after that happened?

(Testimony of C. F. Kirschner.)

A. Mr. Clark and Mr. Sprinkle got out of their car. Mr. Clark stayed on the sidewalk and came up 22nd Avenue going north and turned east on Thomas, and walked down the hill, and Mr. Sprinkle cut off and went in a lot on the side beside him, parallel, and Mr. Clark went into the rear of 231-23rd North, and he knocked on the door.

Q. Was that during your line of vision or sight?

A. Yes, it was.

Q. And what did you observe as he went and knocked on the door?

A. I observed him knock on the door, and he waited a minute or two, and then the door was opened, and it was opened by Mr. Blassingame, and he and Johnny Clark went in the house.

Q. And then what happened?

A. We waited there. That was about 9:40 p.m., and maybe four or five minutes later a car came by the front of us there, and I recognized a girl I knew at that time named Chinkie Johnson, driving an Oldsmobile; and she ran in the house for approximately two or three minutes, and then she turned around and came out, and she passed [171] this way—and she drove off in her car, and she passed this way, and then it was at 10:01 Johnny Clark came back out of the house, and he walked up Thomas Street to 22nd.

Q. At the time he came out of this house, who, if anyone else, did you observe at that door?

A. Sam Blassingame was standing at the door when Johnny Clark came out.

(Testimony of C. F. Kirschner.)

Q. Are you sure about that?

A. Absolutely.

Q. How could you be sure it was Sam Blassingame?

A. I had a good view. The light was on the adjoining porch—not house, it is a continuous porch. There was a little fellow out on the other side of it mopping or sweeping out there.

Q. And would you recognize that fellow again if you saw him?

A. Possibly. He reminded me, from where I viewed him—I never saw him before—he looked like an Oriental, Japanese or possibly a light-skinned Negro.

Q. Will you tell the jury how you were able to so positively identify Mr. Blassingame?

Mr. Chavelle: I object, your Honor. Asking an opinion question.

Mr. Roberts: I am asking for the fact.

The Court: Objection overruled. [172]

A. I have known Sam Blassingame for possibly eight years, and talked to him numerous times.

Q. (By Mr. Roberts): All right; after Johnny Clark left the apartment, what then did you do?

A. We viewed Johnny Clark until he got to the other car, and Mr. Waitt and Sprinkle and Mr. Gooder were in, and we saw him enter the car then and we drove off and went to the Federal Building, or to this particular building, and the Federal Narcotics Office.

Q. What did you do there?

(Testimony of C. F. Kirschner.)

A. We viewed Mr. Fahey take a statement from Mr. Clark.

Q. Will you describe who was present, if anyone other than yourself and Mr. Fahey, at the time the statement was taken from Mr. Clark?

A. There was Mr. Waitt, Sprinkle, Henaby and myself and Mr. Fahey and Mr. Gooder there.

Q. Pardon me. I am writing here. Would you remind repeating a little slower the names?

A. The four Seattle Police officers, Waitt and Sprinkle and Henaby and myself, and then of the Federal Agents there was Mr. Gooder and Mr. Fahey.

Q. And that was the same evening?

A. That was the same evening, yes. [173]

Q. Incidentally, what were the weather conditions in this City of Seattle on May 29, 1956, if you recall?

A. It was clear. It was clear, an average evening. It had been a nice day that day.

Q. Now, inviting your attention to on or about June 19, 1956, state whether or not you met with Johnny Clark on that date?

A. Yes, at nine o'clock p.m. we met Johnny Clark, Detective Sprinkle, Detective Henaby and myself, met Johnny Clark, at the King Street station.

Q. What did you do?

A. We again went to 7th and Madison and met the Federal Agents.

Q. Then what happened?



(Testimony of C. F. Kirschner.)

A. After a short conversation there with all the agents and Mr. Clark, then Mr. Fahey and Mr. Du Puis and myself left the scene.

Q. And where did you go?

A. We went to 26th and Thomas; 26th North and Thomas.

Q. Could that have been 26th North and East John? A. No; 26th North and East Thomas.

Q. And what does that intersection look like?

A. It is only two streets, actually. It is not a four-way intersection. 26th Avenue runs—if you were going [174] in a northerly direction, you would have to turn at Thomas to the right, or turn east. Thomas is heading west there. You would have to turn south on 26th. There is only one corner. The rest is more or less of a radius.

Q. As you look west from the center of that intersection, what do you observe?

A. If you look west from there, what do you observe? Oh, a flight of stairs going to East Madison Street.

Q. What lights are in the area?

A. One light at the bottom of the steps, an old-type light, and then on Madison Street there are three sodium vapor lights lighting the entire area for possible three-quarters of the way down the stairs.

Q. What was the light condition at the base of the stairs around that intersection?

A. It was dark—semi-dark. It wasn't too good.

Q. All right; in arriving there, what did you do?

(Testimony of C. F. Kirschner.)

A. Immediately on arriving there we went up and Mr. Fahey and I—Du Puis was driving—as we got there, we stepped out of the car and we searched the fire plug on the corner.

Q. What was the condition of the ground around the fire plug?

A. It was dry. There was grass around there close to the plug. It was beaten down, possibly one-foot to one [175] and one-half feet close to the plug, like it had been trimmed at one time, and then the grass gradually tapered up to two feet, and sometimes three feet on the parking strip.

We searched this area six feet around the plug very thoroughly.

Q. And then what did you do?

A. We got in the car and went down the hill, and went down Thomas Street and crossed the alley, and as we crossed the alley we stopped the car and had a discussion, and I stepped out, and Mr. Du Puis drew my attention to the stairway.

Q. Can you approximate and tell us the length of time that elapsed from the time you first left the fire plug and your examination until the time you left the car down below the hill?

A. It wouldn't be over two minutes.

Q. Did you have a view of the intersection during that intervening time?      A. Yes, we did.

Q. What, if anything, did you do concerning a view of that intersection as you were going down the hill?

A. We kept it in constant view all the time.

(Testimony of C. F. Kirschner.)

Q. Why?

A. We believed someone else was coming there.

Mr. Chavelle: I will object to that and [176] ask that it be stricken.

The Court: The motion is denied.

Q. (By Mr. Roberts): All right; you got out of the car. What happened then?

A. I got out first, and immediately upon getting out, due to Mr. Du Puis' drawing my attention to the stairway, I saw someone coming down the stairway, and, as I got out, I could hear Mr. Fahey getting out behind me, and I went up and kept to the left of the sidewalk, and the lawns over this place are gradually terraced. I continued to go within fifty feet of the corner where the last terrace is raising to the fire plug, and at that point I could feel or see—I don't know how to express it, but there were some lights behind me, and I thought a car was coming, and I flattened out on the terrace, and I was from here to the back of the courtroom, or probably to the back bench, from the corner; and at that point there I laid and watched Mr. Blassingame come over.

Q. Tell us what you first observed from that distance?

A. I saw Mr. Blassingame just coming to the fire plug.

Q. Was he across the street?

A. He was just at the fire plug. I flattened [177] right out, and that was my first observation.

Q. What did you then observe him do?

(Testimony of C. F. Kirschner.)

A. Pardon?

Q. What did you observe him do?

A. He stopped by the fire plug and then he turned and immediately went back to the steps.

Q. Was he running, or walking?

A. I would say going pretty fast, at a real fast walk, going to the steps.

Q. And then what happened?

A. Then he went up possibly seven or eight steps, and then he stopped and turned around.

At the time that this car that was approaching up the hill had his headlights on Mr. Blassingame, and he turned and went to the second landing, and there he stopped and looked, and then he got to the head of the steps, and paced back and forth, and by that time Mr. Fahey came up to me and the two of us went over in some brush on the corner, and he was approximately one hundred feet from us on Madison Street on the sidewalk.

Q. And then what happened?

A. He walked back and forth there for possibly thirty seconds looking down, and then he got into a car.

We could see the top of the car, and we heard the door slam. [178]

Q. After that, what did you do?

A. We went back to the fire plug and leaning on the left side of the fire plug was a rubber container filled with white powder.

The Court: Mr. Roberts, how much longer?

(Testimony of C. F. Kirschner.)

Mr. Roberts: I must advise the Court it will probably be ten minutes more.

The Court: We will recess.

Members of the Jury:

We will now recess until tomorrow morning at ten o'clock. The Court calls your attention to the admonition given you earlier this morning, and asks that you heed it on this occasion.

Again, it is important to not reach any conclusions or form any opinions with respect to the merits of the case until you have heard all the evidence and the instructions of the Court, and when you are all leaving and at your homes it is not permissible to talk with your own families or anyone else while sitting on a case regarding the merits of the case. Tell them it is a narcotics case, if you wish, but that is as far as you can go, and it is necessary to refrain from disclosing to anyone any matters relating to the case until after the case has been decided.

You may now be excused until tomorrow morning, and be here at ten minutes to ten. [179]

(Whereupon, the jury retired from the courtroom.)

The Court: Court will recess until tomorrow morning at ten o'clock.

(Whereupon, at 4:38 o'clock p.m., January 15, 1957, a recess was had in the within-entitled and numbered cause until 10:00 o'clock a.m., January 16, 1957.) [180]



Jan. 16, 1957—10:00 A.M.

The Clerk: United States of American versus Sam Blassingame, Cause No. 49488, now on for further trial.

Mr. Roberts: The plaintiff is ready, your Honor.

Mr. Chavelle: The defendant is ready, your Honor.

Mr. Roberts: Your Honor, I have served one additional copy and have served a copy on the defendant, and given a copy to the Clerk.

The Court: You have a copy?

Mr. Chavelle: We have a copy, your Honor.

The Court: You may call the jury.

(Whereupon, the jury was returned to the courtroom.)

The Court: You may be seated.

It is stipulated that the defendant and the jury are present in the courtroom?

Mr. Roberts: So stipulated

Mr. Chavelle: So stipulated, your Honor.

The Court: You may proceed.

You are still on direct testimony, is that correct?

Mr. Roberts: Yes, your Honor, I believe I [184] was.

### C. F. KIRSCHNER

upon being recalled as a witness for and on behalf of the plaintiff, and having been previously duly sworn, testified as follows:

#### Direct Examination (Continued)

(Testimony of C. F. Kirschner.)

By Mr. Roberts:

Q. Mr. Kirschner, as I recall, when we left off yesterday afternoon, you had just testified that after having seen Mr. Blassingame go up the stairs, you and Mr. Fahey, on the evening of June 19, 1956, were standing at the base of the stairs at the intersection of what you testified to as 26th and East Thomas, and you were observing the defendant walking back and forth at the head of the stairs on Madison Street.

What, then, did the defendant do?

A. The defendant got into an automobile that was parked down forty or fifty feet, I would judge, on Madison Street, and he got into a car and sat on the right-hand side of the car and the car proceeded down Madison Street.

Q. How are you able to say he sat on the right-hand side of the car?

A. You could see him there as the car took off.

Q. Can you describe the car as to make and model?

A. It was a light colored car; it could have been blue or green, but the sodium vapor lights kind of make the [185] colors a little different than what they really are. I couldn't definitely say for sure.

Q. At the time you observed him at the head of the stairs, why didn't you go and make an arrest?

A. We wanted to make certain that the evidence was what we expected had been left at the base of the fire plug. We wanted to make sure and to test it.

(Testimony of C. F. Kirschner.)

Q. What do you mean by that? I want you to explain.

A. We wanted to be positive it was heroin that had been left at the plug.

Q. Now, at this point, how much time had elapsed, in your estimation, from the time that you first arrived at the fire plug until the time you saw Mr. Blassingame leave in an automobile?

A. Oh, I would say in the vicinity of maybe six minutes.

Q. Now, would you break that down as best you can for the jury as to the time involved in each of the steps along the way from the time you investigated the plug area?

A. Well, we first pulled up to the plug, and we were there approximately from the time we parked and Mr. Du Puis got up and assisted us in the search, and we looked around there possibly one and one-half minutes, and maybe two minutes. Then from there we drove down the hill and we discussed this as we went down the hill, and we got to [186] the alley and stopped just across the alley, and as we stopped I started to get out of the car, and immediately Mr. Du Puis drew my attention to the stairway; and, as I had been keeping the plug under surveillance, I wasn't paying attention to the stairway, and I started then to run up, and I imagine I was up there, three and one-half minutes from the time I saw Mr. Sam come down and run up the steps and get in the car, would take up the remainder of the time. Actually Mr. Blassingame was

(Testimony of C. F. Kirschner.)

in our sight maybe three minutes at the most.

Q. Now, with particular reference to the time after searching the plug and you re-entered the car and drove down on Thomas Street and returned over one-half block, how much time elapsed in that time?

A. Oh, we drove down the street about, probably ten or fifteen miles an hour and stopped the car, and I got out at that time and was standing by the side of the car looking at the plug, and that probably would have taken ten or fifteen seconds to get down there, and it was practically immediately after getting out of the car that Mr. Du Puis spoke up, and I ran up the left-hand side.

Q. And did anyone else during that interval of time, from the time you left the plug until you returned to it, come into the plug area? A. No.

Q. How are you able to be definite on that? [187]

A. I could see the top of the plug.

Q. Could you see the entire plug?

A. No, not the entire plug.

Q. Was it possible someone could come into the plug area?

A. If they crawled, it would have been possible.

Q. Now, after Mr. Blassingame left in the car down Madison Street at the head of the stairs, what then did you next do?

A. We went up to the plug, Mr. Fahey and I, and at that time we put our flashlights in the plug area.

Mr. Chavelle: This was all gone into yesterday, your Honor, step by step.

(Testimony of C. F. Kirschner.)

The Court: With this witness?

Mr. Chavelle: What he is covering now, yes. He is going into what was testified to yesterday with the flashlight and going around beneath the plug.

Mr. Roberts: My recollection is I thought we left off yesterday when they just saw Mr. Blassingame leaving the car at the head of the stairs and returned to the plug.

The Court: That is my recollection. My notes don't indicate any detail on this. Objection overruled. You may continue.

A. (Continuing): Mr. Fahey and I went to the plug [188] and then played our flashlights at the base of it and on the left-hand side, leaning—on the north side of the plug, actually—against it there was a rubber container approximately this big and so wide (indicating). It was leaning on the plug and we viewed it, and Mr. Du Puis at that time was not there and we wanted him to view it in this position, and so we waited until he came back.

Q. (By Mr. Roberts): At this time I will ask you to examine Plaintiff's Exhibit No. 2, the contents of the envelope, and state what it is, if you know?

A. This is the rubber container that we found at the base of the plug. My initials are here in green ink, "C. K.," and at the same time Charlie Fahey and Charles Du Puis placed their initials on it.

Q. At the time you saw that, state what tax stamp or stamps of any kind were attached to it?

A. There were no tax stamps. It was in the same



(Testimony of C. F. Kirschner.)

condition as this except for the initials and printing done on it by the officers.

Q. Who had that in their possession after you left the plug, if you know? A. Mr. Fahey.

Q. Now, after you returned to the plug from across the street at the base of the stairs, and played your flashlight around and saw this rubber container, what next did [189] you do?

A. We went to the bottom of the stairs, and at that time I called to Mr. Du Puis and stated that they appeared to be coming around the block, and that is when Mr. Du Puis took off and we waited at the base of the stairs.

Q. Where on the stairs or around them were you, specifically?

A. Just within, I believe, about three steps up on the left-hand side of the stairway.

The brush hangs over on that point.

Q. What were you doing at this point?

A. We were trying to conceal ourselves.

Q. Then what happened?

A. About two minutes later a car did come by.

Q. In what direction did it travel?

A. We could see it coming south in 27th Avenue, and then it turned west on Thomas Street, and came up Thomas to 26th, and then went south on 26th.

Q. And the car then continued out of the area?

A. The car continued out of the area.

Q. Did you recognize the car?

A. We weren't trying to be seen. We were trying to hide ourselves.

(Testimony of C. F. Kirschner.)

I didn't recognize the car, no.

Q. All right; and you say that was about [190] two minutes. And then what next happened?

A. Just a little bit before Du Puis came up we waited maybe five minutes for Mr. Du Puis to show right across from the plug, and we saw another car coming up the hill at the time.

Q. What hill? A. Thomas Street.

Q. The same direction as the other car?

A. Yes, coming west.

At that time the car came up, and Mr. Fahey and I were out in the open a little more then.

Q. Where were you standing at the time?

A. We were on the stairway.

Q. In the same position you had been?

A. Generally, except we were over farther, in plainer view.

Q. What were you doing?

A. When this car came up, what we actually did, we put on a drunk act, Mr. Fahey and I, and turned our sides to him trying to avoid being identified ourselves.

Q. And then what happened?

A. Well, this car went right past us and pulled up real quick, and a man got out of the side.

Q. Where did he pull up?

A. About fifty feet north of us, or south [191] of us.

Q. On what street? A. On 26th.

Q. And on what side of the street?

A. On the west side of the street, on the same side we actually were on.

(Testimony of C. F. Kirschner.)

Q. And then what happened?

A. He got out of the car on the driver's side, and came directly to the sidewalk, and came directly towards us and came around the corner and pulled a gun out, and I disarmed him, and we arrested him.

Q. Who was this man?

A. His name was Andrew Leed.

Q. Did you know him?

A. Never saw him before, no.

Q. Have you since learned about him?

A. He was arrested that night, and we held him for a day and a half investigating him.

Q. What was the charge?

A. He was charged with carrying concealed weapons.

Q. What have you learned about his background from that day to this?

A. He is steadily employed by the Fuller Factory Service, and has been for nine years, and he is still, to my knowledge, working there.

Q. What involvement, if any, did you discover he had [192] in the traffic of narcotics?

Mr. Kosher: I will object to that on the grounds it is obviously hearsay.

Mr. Roberts: I am inquiring of a police officer, and possibly I should qualify the question, your Honor, with this preface:

Q. (By Mr. Roberts, continuing): In the course of your business as a narcotics officer with the Police Department of the City of Seattle, have you come to

(Testimony of C. F. Kirschner.)

know of this man in any way with the involvement of narcotic traffic in this city?

A. No, I have not.

Mr. Kosher: The same objection.

The Court: Objection overruled.

Q. (By Mr. Roberts): What kind of a car was this man driving?

A. He was driving a dark blue Pontiac.

Q. A dark blue Pontiac; was it the same car that you observed Mr. Blassingame in?

A. No, the car that Mr. Blassingame was in was a light car.

Q. How much time elapsed from the time you observed Mr. Blassingame leave Madison Street up until the time this man pulled up?

A. Oh, seven or eight minutes. [193]

Q. Now, then, after you arrested this man, what next happened?

A. Well, Mr. Du Puis showed up, and when he showed up I placed the man in the back of Mr. Du Puis' car, and he parked right there, and then Mr. Du Puis and Mr. Fahey and I went to the plug, and Mr. Du Puis viewed this particular rubber container; and that time Mr. Fahey picked it up and we initialed it.

Q. And then what did you do?

A. We all got in Mr. Du Puis' car and drove to Police Headquarters, and at that time I booked the other man.

Q. Now, Mr. Kirschner, from May and June of 1956, to this date, in the interval of time, state

(Testimony of C. F. Kirschner.)

whether or not you have ever discussed the facts of this case with the defendant, Sam Blassingame?

A. Yes, I have.

Q. Where did that discussion take place?

A. In his apartment.

Q. Was there more than one discussion?

A. No, there was just one.

Q. And where is his apartment located?

A. I believe the address is 118-25th North.

Q. And when did this discussion take place?

A. Approximately October 3rd.

Q. And what were the circumstances leading to the [194] discussion?

A. We had gone across the court. Mr. Blassingame at the time was living in a more or less of a bungalow court, and across the court is a fellow named Wally Hanks.

Q. Who is "we"?

A. Two investigators from Portland, Detective Henaby and myself.

Q. What was your purpose?

A. Our purpose was to serve warrants at the other apartment.

Q. All right; what happened when you went to the other apartment?

A. We went over to the other apartment. We were interrogating Mr. Hanks, and Mr. Larry Johnson stated that Sam Blassingame wanted to see me, and Larry, in turn, went over to Sam Blassingame's apartment and came back in a few minutes, and said, "Sam is there," and told me to go on over.



(Testimony of C. F. Kirschner.)

I went over, and I told Mr. Henaby I was going over to see Mr. Blassingame for a few minutes.

I went over there, and Sam opened the door and shook hands.

Q. Does he know you?

A. Yes, he knows me.

Q. How long have you known Sam? [195]

A. Seven or eight years.

Q. What was said by you and by him at that time? Who else, other than yourself and Mr. Blassingame, were present in the apartment?

A. No one, just Sam and myself.

Q. And, once again, what was the date of this?

A. This was, I believe, October 3rd.

Q. 1956? A. 1956, yes.

Q. All right; what was the conversation?

A. When I came in the apartment, I remarked to Sam that he did not have much furniture in the place, or didn't have any, and he said he was making arrangements that day to get furniture; and then he asked me what I thought of the case, and he asked me about the dates, and I said, "I am not too familiar about the dates. The only dates I recall were the 29th, due to the fact it was my birthday that night."

Then he says—and then I asked him, "Who do you think made you, Sam"?

And he stated, "Johnny Clark is the only man that could have made me."

Then I asked him, "Well, you should have been more attentive to your business, Sam."

(Testimony of C. F. Kirschner.)

And he said, "What do you mean?" And I said, "You should pay more attention to your [196] business."

And he said, "You mean the night at the fire plug?"

And I said, "I thought sure you had seen one of us." And he said, "I did." And he said, "I saw you." And I said, "Who did you see, Sam?" And he said, "I saw you and saw—." Oh, it was, the conversation in whole was more or less of a—I was trying to pump Sam, and Sam was trying to pump me.

Then we talked about other mutual acquaintances, and the conversation more or less went along that line; and then I was there possibly ten minutes, and Sam shook hands with me, and I left.

Q. What, if anything, was said by Sam or by you about Johnny Clark testifying in a case against Sam?

A. He stated that he, in his belief, didn't think Johnny Clark would testify against him, because when Johnny got out of the penitentiary he had been like a brother to him, and treated him real good.

Q. Is that, in substance, the conversation in this case?

A. That was part of the whole conversation.

Mr. Roberts: I have no further questions, your Honor.

(Testimony of C. F. Kirschner.)

Cross-Examination

By Mr. Chavelle:

Q. Mr. Kirschner, directing your attention to the [197] date of May 29, 1956, I believe you stated that you placed yourself in a position where you could view the duplex?

Directing your attention to the date of May 29, 1956, I believe you testified on direct examination that you placed yourself in a position where you could view the duplex where Johnny Clark supposedly was sent into?

A. That is correct.

Q. And I think you testified you saw a woman called Fitzgerald, or "Chinkie" Johnson, enter the apartment or duplex?

A. That is right.

Q. You have been in police work a long time, and you are acquainted with Miss Fitzgerald, also known as "Chinkie" Johnson?

A. That is correct.

Q. Tell us about her background as far as narcotics is concerned or prostitution?

A. As far as her background is concerned, Mr. Chavelle, I don't know too much about it except she was a girl friend of Sam Blassingame's at the time, and she came to my attention first at this time.

Q. And did you know her before, as far as being associated with narcotics addicts, or a user?

A. No, the first thing I knew of her, her name

(Testimony of C. F. Kirschner.)

came up as the girl friend of Sam [198] Blassingame.

Q. Did you know her that night when you saw her?  
A. Yes, I did.

Q. And you knew her prior to May 29, 1956?

A. I had made it a point to introduce myself to her.

Q. And was she a prostitute, do you know?

A. I do not know from my own knowledge.

Q. How long was she in the house that night?

A. I would judge two minutes.

Q. She came in and stayed there about two minutes?

A. That is right, from the time she went through the door and came back out.

Q. She had entered and left before Johnny Clark came out, is that right?

A. She was there—she was in there at the same time Johnny Clark was in the house.

Q. And Johnny Clark was still there after she left?  
A. That is right.

Q. How steep a grade is that hill on east?

A. Oh, probably 10 per cent grade.

Q. You say 10 per cent grade?

A. Well, I am not a very good judge of grades.

Q. Could it be 35 per cent grade?

A. No, I don't think it would be 35 per cent grade.

Q. Is it quite a steep hill?

A. Oh, it would be about the same as on Madi-

(Testimony of C. F. Kirschner.)

son [199] Street, between 5th and 6th Avenues, alongside this building.

Q. How far is that hydrant located from the corner of the intersection there; how far?

A. I think you are confused, Mr. Chavelle. We are at two different—are we talking about Chinkie Johnson's?

Q. No, I am talking about East Thomas Street. Are you telling me about some other corner?

A. I was telling you about the corner where Johnny Clark went in.

Q. Let's go back to the corner on East Thomas.

A. 26th and Thomas?

Q. Yes.

A. That is about a 15 per cent grade.

Q. 15 per cent grade?           A. Yes.

Q. Not 35 per cent?           A. No.

Q. How far is the hydrant south of the intersection there?

A. It would be from the actual curb line of East Thomas Street, it would be probably ten feet south and about one foot in from 26th— one foot to one and one-half feet in from 26th. That would be east of the 26th curb line, about four feet from the sidewalk.

Q. Is it a residential district of homes [200] throughout that vicinity?

A. Throughout the particular vicinity, but not in that exact location. It was not very well—it is empty lots there.



(Testimony of C. F. Kirschner.)

Q. Located in front of some residential property?

A. No, the closest one is about a city lot away.

Q. There are homes near the fire plug?

A. There are homes in the block, but on Thomas Street it would be possibly 100 feet south of there—that would be on 26th, and the closest home on East Thomas, the first house down would be, I believe it is a small—a short lot in between, and then the first house.

Q. Isn't it a fact that there is a house not less than 15 feet away from that plug?

A. Fifteen feet away from the plug? No, there wouldn't be a house that close.

Q. Are you sure of that?

A. I am sure of that.

Q. You are positive?

A. Positive, Mr. Chavelle.

Q. The stairway referred to, is that about one city block long?

A. It would be about, oh, 100 feet.

Q. 100 feet long? A. 100 feet long. [201]

Q. When the car came to a stop, that was about 60 feet down East Thomas Street?

A. About 40 or 50 feet down the hill.

Q. And you say he would be approximately 160 feet away from the top of the stairway, where the car was stopped?

A. I didn't understand.

Q. You say it would be 160 feet away from the

(Testimony of C. F. Kirschner.)

top of the stairway to where the car was located when stopped?

You say you stopped down by the alley, is that correct?      A. Yes, that is right.

Q. Now, I am asking you, from the alley to the top of the stairway how many feet is it?

A. One-half a city block to the base of the stairway, and another 100 feet to the top.

Q. Now, you stated, Mr. Kirschner, no arrest was made until you could determine what Plaintiff's Exhibit No. 2 contained, whether or not it was heroin, is that right?      A. That is right.

Q. When was it determined that this Plaintiff's Exhibit No. 2 contained heroin?

A. When we went down to the office we made what is called a field test on it, I think a Marquis reagent, and it showed it was an alkaloid, and at that time it was [202] determined it was heroin.

Q. June 19, 1956, you determined this package contained heroin?      A. That is right.

Q. And when was the arrest made in this case?

A. I believe it was made September 27th.

Q. Yet you stated the reason you didn't make the arrest that night was because you wanted to test this package, and you did determine it contained heroin, and no arrest was made until September 27; is that correct?      A. Other reasons came up.

Q. I thought you testified on direct examination the only reason you didn't arrest him was until you learned what was at the fire plug?

A. That was the reason that night.

(Testimony of C. F. Kirschner.)

Q. He was available at all times for arrest, was he not?      A. Yes, he was.

Q. Subsequent to June 19, 1956, and also subsequent to May 29, 1956?      A. Yes.

Mr. Chavelle: That is all, sir.

#### Redirect Examination

By Mr. Roberts:

Q. What other reasons, Mr. Kirschner, came up, that [203] caused you not to arrest Sam Blassingame shortly after June 19th?

A. Due to using Johnny Clark, we didn't want to divulge that he was our informant in the case.

Mr. Roberts: I have no further questions.

Mr. Chavelle: That is all, sir.

(Witness excused.)

Mr. Roberts: Mr. Henaby. [204]

#### WILLIAM E. HENABY

upon being called as a witness for and on behalf of the plaintiff, and upon being first duly sworn, testified as follows:

The Clerk: Will you state your full name and spell your last name, please?

The Witness: William E. Henaby, 11027 Palatine Avenue.

#### Direct Examination

By Mr. Roberts:

Q. What is your occupation?

(Testimony of William E. Henaby.)

A. Police Detective, employed by the City of Seattle.

Q. Any specialty with the Police Department?

A. Yes; with the Narcotics Detail.

Q. How long have you been employed as a police officer with the City of Seattle?

A. About nine and one-half years.

Q. Directing your attention to on or about May 29, 1956, state whether or not you met at 19th and Roy with other officers and one Johnny Clark?

A. Yes, I did.

Q. What happened previous to that time?

A. After arriving there Detective Sprinkle and Johnny Clark went into a public phone booth. Clark made a [205] phone call, and I then proceeded to the intersection of 22nd and East Thomas.

Q. With whom?

A. With Agent Fahey and Detective Kirschner.

Q. And what did you do there?

A. Shortly after arriving there, another Government vehicle pulled up below the intersection, and at that time Johnny Clark emerged from the car and walked to a house at 231-23rd North.

Q. Did he walk alone to that house?

A. He walked alone. Detective Sprinkle was in the lot following him.

Q. Now, did you have a view of the house you just identified?

A. Yes, I did.

Q. Will you describe what you observed and where you were parked at that house, and the distances involved?

A. The distance would be approximately one-

(Testimony of William E. Henaby.)

half of a downtown city block. It is a block in that area. They are short blocks.

Q. And what did you see as you looked towards this apartment?

A. I observed Clark and Sprinkle walk toward the house. Sprinkle, I don't think, approached any nearer than 30 feet of the back porch. [206]

Clark went to the door.

Q. Let me interrupt, and ask you what would you observe as you looked from your position of vantage toward the rear door?

What was around the rear area?

A. There was a vacant lot between our position and the back door.

Q. So that your view was obstructed, or unobstructed?      A. It was unobstructed.

Q. As Clark approached the back door, what did you observe?

A. He walked up on the porch, and the door was opened by Mr. Blassingame.

Q. Did you recognize Mr. Blassingame at that time?

A. Yes, I did; and then he was admitted.

Q. Approximately what time of the day was this?

A. It was shortly after 9:30. I would say about 9:35, or 40.

Q. A.M. or P.M.?      A. P.M.

Q. And then what happened?

A. While we were sitting there, an—about a 1954 Oldsmobile drove directly in front of us and



(Testimony of William E. Henaby.)

proceeded to East Thomas, and parked near the back entrance of 231-23rd North. A woman got out of the car, and went into the house, [207] and she was in there approximately two or three minutes, at the most.

Q. Did you recognize that woman?

A. I recognized her as Chinkie Johnson, a woman I knew.

Q. How long was she in the house?

A. Not over two or three minutes.

Q. And then what happened?

A. Then she emerged from the house and drove away.

Q. Then what happened?

A. Clark was in there perhaps ten minutes after she left. I think he was in there about twenty minutes. He returned to the door with Mr. Blassingame, and Mr. Blassingame—during the time they were in there, there was some gentleman that came out on the far porch of the adjoining apartment or duplex and he turned a light on, and was sweeping the porch off, and then approximately five minutes after that Mr. Clark came out with Mr. Blassingame at the door.

Q. Did you recognize it was Mr. Blassingame at that time?      A. Yes, I did.

Q. Did you know him at that time?

A. Yes, I have known him for a long time.

Q. And then what happened? [208]

A. Then Clark walked over to the sidewalk on the south side of East Thomas and then walked west

(Testimony of William E. Henaby.)

to the intersection of 22nd and East Thomas, with Sprinkle following him up through the lot, and they walked to the Government vehicle.

Q. Now, directing your attention to June 19th, on or about that date, 1956: Did you have occasion to meet Clark again?

A. Yes. Detective Kirschner, Sprinkle and I met Johnny Clark at the King Street depot at approximately 9:00 or shortly thereafter.

Q. And later on in the evening did you——

Mr. Roberts: Strike that.

Q. (By Mr. Roberts, continuing): Briefly, what happened thereafter?

A. We had a prearranged meeting with members of the Federal Bureau of Narcotics at a parking lot at 7th and Madison, and we drove there and met Agent Fahey and Agent Du Puis. There were two other Government employees there.

There was James Clark, a United States—a Deputy United States Marshal, and a Clerk from the Federal Bureau of Narcotics, Lee Holt.

Q. What happened at that meeting?

A. At that meeting we had conversation [209] with Johnny Clark.

Q. Following your conversation, what happened?

A. Detective Sprinkle and I remained in the car with Johnny Clark.

Detective Kirschner, Agent Fahey and Du Puis departed from the parking lot.

Q. Now, did they thereafter return or rejoin you?

(Testimony of William E. Henaby.)

A. Yes, shortly after 10:00 o'clock they rejoined us. Kirschner and Fahey came back to the car I was seated in, and Fahey showed me an article he found while he had been gone.

Q. I will ask you to examine the contents of Plaintiff's Exhibit No. 2, and state what it is, if you know?

A. Yes, this is the article that Fahey showed me after they returned on that evening.

Q. How are you able to make that statement?

A. I have my initials on it. I also recognize the fingerprint powder that we applied to the article.

Mr. Roberts: I have no further questions.

Mr. Chavelle: No questions.

(Witness excused.)

Mr. Roberts: We will call Mr. Waitt. [210]

### ROBERT W. WAITT

upon being called as a witness for and on behalf of the plaintiff, and upon being first duly sworn, testified as follows:

The Clerk: State your full name and spell your last name, please?

The Witness: Robert W. Waitt, W-a-i-t-t (spelling).

### Direct Examination

By Mr. Roberts:

Q. So that all of the members of the jury can

(Testimony of Robert W. Waitt.)

hear your name, please state it again, louder, please?

A. Robert W. Waitt, W-a-i-t-t (spelling).

Q. Where do you live, Mr. Waitt?

A. 13219-1st Southwest, Seattle.

Q. What is your occupation?

A. Seattle Police Officer.

Q. And during the months of May or June, 1956, were you so employed?      A. Yes, I was.

Q. Directing your attention to on or about May 29, 1956, state whether or not you met with one Johnny Clark during that day?

A. I did. [211]

Q. Where did you meet him?

A. I met him at the King Street station.

Q. Did you thereafter go to a rendezvous meeting at 7th and Madison in this city?

A. Yes, I did.

Q. Did you thereafter travel with other officers?

Mr. Chavelle: This is leading and suggestive. He can state what he did.

Mr. Roberts: Very well, Your Honor. I was merely trying to shorten the interrogation.

Q. (By Mr. Roberts, continuing): State whether or not at any time that evening you were at the corner of 19th and Roy Street in this city?

A. I was.

Q. Approximately what time of the day was it?

A. It was in the evening, approximately twenty minutes to ten; 9:40—somewhere in there.

Q. All right. What happened there?

A. At 19th and Roy?

(Testimony of Robert W. Waitt.)

Q. Yes.

A. I arrived there at 19th and Roy in a Government automobile driven by Sam Gooder. In the car was myself, Detective Sprinkle, and Johnny Clark.

Q. Will you speak up loudly so that we [212] can all hear you?

A. I stayed in the car. Johnny Clark and Detective Sprinkle got out of the car and went to a phone booth. They came back in a few minutes. There was a conversation, a short conversation, and the four of us then proceeded to the vicinity of 21st and Roy.

Q. Now, then, who are the four of you, once again?

A. Detective Sprinkle, Agent Gooder, Johnny Clark and myself.

Q. What did you do at 21st and Roy?

A. At 21st and Roy I removed Johnny Clark's coat, sport coat or suit coat, and with his assistance I removed his shirt. He was wearing a white shirt. I removed his shirt, and Detective Sprinkle helped me, and we put on him a small recording device.

Q. What was Mr. Gooder doing at the time?

A. Mr. Gooder was searching the person of Johnny Clark.

Q. Will you describe what you observed concerning that search?

A. As I was in the process of putting on this wire recorder, Detective—Agent Gooder was searching the person of Johnny Clark. Johnny unbuttoned, unloosened, his belt from his pants, and Agent



(Testimony of Robert W. Waitt.)

Gooder put his hands inside his pants and searched around the middle part of his waist. [213]

Q. Did you observe whether or not Agent Gooder observed the lower extremities?

Mr. Chavelle: Leading and suggestive. You can ask what he did.

Q. (By Mr. Roberts, continuing): What else did you observe concerning the search?

A. As I continued to do what I was doing, I saw Agent Gooder patting Johnny Clark's legs, and work on down towards his feet.

Q. Did you see what he was actually doing down there?

A. No, sir; I did not see what he was doing down there.

Q. Did you observe any Treasury Department order forms for Narcotic purchases on Johnny Clark's person that evening? A. No, sir.

Q. Or any mentioned or discussed?

A. No, sir.

Q. Were you present—

Mr. Roberts: Strike that.

Q. (By Mr. Roberts, continuing): Now, after this, what then happened?

A. After Agent Gooder had completed, had apparently completed his search, I saw him give Johnny Clark some money. [214]

We then proceeded to 22nd and East Thomas Street, where we parked the car.

Q. Then what happened there?

A. Johnny Clark got out of the car and walked

(Testimony of Robert W. Waitt.)

kitty-corner across the street, heading—at first he was walking in a northeasterly direction, and as he neared the southeast corner of the intersection, on the corner he turned and walked east down a hill out of my sight.

Q. And who, if anyone else, was with him at that time?           A. Detective Sprinkle.

Q. All right. Now what next happened?

A. I at that time was sitting in the back seat of the car. I got from the back seat into the front seat with Agent Gooder. We waited there approximately twenty minutes, maybe a little more than twenty minutes.

I saw Johnny Clark reappear from over the hill and walk directly to our car with Detective Sprinkle following him.

Q. And then what happened?

A. He came to our car and opened—Agent Gooder opened the back door, and as Johnny Clark got in, he handed him a package.

Q. Did you observe that package?

A. Yes, I did. [215]

Q. Would you examine the contents of Plaintiff's Exhibit No. 1, Mr. Waitt, and state what it is, if you know?

A. This is the package that I saw Johnny Clark hand Agent Gooder as he arrived back in our automobile.

Q. How are you able to make that definite statement?

(Testimony of Robert W. Waitt.)

A. At that time I placed my initials on it, and I see my initials on it today.

Q. Now, at the time you observed it in the car when Clark delivered it, state what, if any stamps appeared on that parcel, if any?

A. There were none.

Mr. Roberts: I have no further questions.

Mr. Chavelle: No questions.

(Witness excused.)

Mr. Roberts: Your Honor, with the Court's permission, I would like to call Mr. Gooder back for additional direct examination on one point only, which I believe is material to the Government's case.

The Court: Is that by virtue of Clark's testimony?

Mr. Roberts: Yes, Your Honor, in part, but also relating to the matter of Department Order Forms and Treasury Order Forms.

The Court: All right.

Mr. Roberts: Mr. Gooder? [216]

### LAVERN E. GOODER

upon being recalled as a witness for and on behalf of the plaintiff, and having been previously duly sworn, testified as follows:

#### Direct Examination

By Mr. Roberts:

Q. Mr. Gooder, you have previously been sworn in this matter.

(Testimony of Lavern E. Gooder.)

I direct your attention back to your testimony about having searched the person of Johnny Clark on the evening of May 29, 1956, at or around 21st and Roy Street in this city.

I now ask you to state what, if any, Treasury Department Order Forms for the purchase of narcotics did you observe or find on his person at that time?

A. There were no order forms upon the person of Johnny Clark at all.

Q. Now, thereafter, as earlier testified, you once again searched his person, some time later that evening?

A. Yes.

Q. And that would be in the vicinity of 22nd and East Thomas Street, if I recall correctly.

State what, if any, order forms such as I have just described, Treasury Department Order Forms for the [217] purchase of narcotics, were found on his person at that time?

A. He still had no order forms.

Mr. Roberts: I have no further questions.

Mr. Chavelle: No questions.

(Witness excused.)

Mr. Roberts: For the same purpose, Your Honor, I would like to call Mr. Fahey back.

Mr. Chavelle: It is cumulative, Your Honor.

The Court: Pardon?

Mr. Chavelle: It is cumulative. Mr. Gooder has testified there were no treasury forms.

Mr. Roberts: There is a question in my mind as to whether it is definitely established.

The Court: I don't know that the testimony indicates Fahey searched him, did he? Is there testimony that Fahey searched? You say it is the same matter?

Mr. Roberts: It is the same matter but the other exhibit, Your Honor, relative to tax stamps. Also, I am advised Mr. Fahey wants to correct testimony he delivered yesterday.

The Court: All right; you may call him.

Mr. Roberts: Mr. Fahey. [218]

### CHARLES FAHEY

upon being recalled as a witness for and on behalf of the plaintiff, and having been previously duly sworn, testified as follows:

#### Direct Examination

By Mr. Roberts:

Q. Mr. Fahey, you have previously been sworn in this matter.

A. (Witness nodded in the affirmative.)

Q. I invite your attention back to your testimony of yesterday, in which you described for the jury an intersection at 26th Avenue North and East John Street in the City of Seattle.

You have indicated to me that you wish to correct your testimony?      A. Yes, sir.

Q. Will you now state what your testimony is as to that intersection, definition of streets?

A. It is at 26th and East Thomas, and not East



(Testimony of Charles Fahey.)

John. The two streets I confused, and have for years.

Q. How are you able to be definite about it this morning, sir?

A. Well, I not only looked at my notes, I drove out there last night and looked at the streets. [219]

Q. Now, what, if anything, led you astray in your testimony yesterday?

A. I used to live in an apartment facing John, and I called it Thomas for five years, and I noticed on my envelope, Exhibit No. 2, while the exhibit itself is marked properly, I note "John" on the envelope. I was wrong. It is Thomas.

Q. Now, then, with relation to Plaintiff's Exhibit No. 2, will you state whether or not at the time you found it at the fire plug it had affixed to it any Federal tax stamps? A. It had none.

Q. It had none; state whether or not you have ever had a discussion with Johnny Clark in which you may have promised him some help if he would co-operate with the Government in this case?

Mr. Chavelle: That is hearsay, Your Honor; and we object; a discussion or conversation with Johnny Clark by this witness.

The Court: We have not reached that yet.

Mr. Roberts: I might advise the Court I believe that properly this is rebuttal testimony, but in saving time——

Mr. Chavelle (Interposing): It certainly wouldn't be proper rebuttal at this stage of the proceedings [220] until we put on our case.

(Testimony of Charles Fahey.)

Mr. Roberts: As to matters brought out on cross-examination.

The Court: I think it is properly rebuttal.

Mr. Roberts: I certainly agree with the Court, and my purpose in asking the question at this time——

The Court (Interposing): If you really wish to ask the question, did he have a discussion, you may answer that question yes or no.

A. Yes, I had a discussion with Johnny Clark.

Q. (By Mr. Roberts): All right; what promise, if any, did you make to Clark?

Mr. Chavelle: I am objecting to that as hearsay. That would definitely involve a conversation between this officer and Johnny Clark, and violates the hearsay rule.

Mr. Roberts: He can state what he did, but not what Clark may have said.

The Court: Well, I will overrule the objection. It is not what Clark said, but merely what this witness did or said.

Mr. Roberts: I believe the foundation, Your Honor, is the testimony of——

The Court (Interposing): Go ahead. [221]

Mr. Roberts (Continuing): ——of Mr. Gooder about this discussion.

A. In November, as I recall, I told Mr. Clark that this United States Attorney's office would—should he follow through and tell the truth, this United States Attorney's office would refer his cooperation in the case to the State's attorney for

(Testimony of Charles Fahey.)

whatever consideration they would take in their action against him.

Q. (By Mr. Roberts): What facts, if any, led you to have such a discussion with Mr. Clark in November of last year?

A. I had reason to believe that from information that Mr. Clark——

Mr. Chavelle (Interposing): I object to that information. It is undoubtedly hearsay, your Honor. His reason to believe is based on information obtained from some other person or persons, and would be obviously hearsay, your Honor.

Mr. Roberts: I believe he can testify as to what he knew in the course of his business as a Federal Narcotics Agent.

Mr. Chavelle: He said he "obtained information." Obviously it is based on hearsay.

The Court: What rule of hearsay applies to that? [222]

Mr. Chavelle: Well, he is going to base his testimony now on something that is going to happen, and he said he received information.

The Court: He is explaining why he did something.

Mr. Chavelle: All right.

The Court: It bears on motive and intent.

Q. (By Mr. Roberts): All right.

A. I had reason to believe that Johnny Clark would not co-operate with our office in this matter.

Mr. Roberts: I have no further questions.

(Testimony of Charles Fahey.)

Cross-Examination

By Mr. Chavelle:

Q. Do you want to correct any other testimony you gave yesterday?

A. None that I can think of, counsel.

Q. None you can think of right now?

A. I believe that was my only glaring error.

Mr. Chavelle: All right. That is all.

(Witness excused.)

Mr. Roberts: At this time, your Honor, the plaintiff offers in the case Plaintiff's Exhibits Nos. 1 and 2 now marked for identification. [223]

Mr. Chavelle: No objection to them, your Honor.

The Court: Exhibits Nos. 1 and 2 may be admitted.

(Plaintiff's Exhibits Nos. 1 and 2 admitted in evidence.)

Mr. Roberts: Thank you, your Honor. The plaintiff now rests.

Mr. Chavelle: We would like to make a motion, your Honor.

The Court: All right.

Members of the Jury:

The Court will excuse you for the mid-morning recess, and the Court calls your attention to the admonition given you yesterday on a similar occasion, and asks that you heed it on this occasion.

You may now be excused.

(Whereupon, the jury retired from the court room.)

Mr. Kosher: Your Honor, the United States of America having rested, the defendant, Sam Blasingame, now moves this Court to dismiss Counts 1 and 2 of this Indictment for the reason that there is no proof in this case sufficient to take this case to the jury.

I think a fair summation of the evidence [224] is simply this:

That these Narcotic Agents together with police officers had some reason to believe that Johnny Clark could make a buy for them; that thereupon, they gave him some money and they watched him go into a certain house, and I would say that a fair inference is that he was admitted to the house by the defendant, and that he was in the house a short period of time, and thereafter a woman appeared and went into the house.

There is also evidence that there was some person, apparently, in the next house. No evidence that Blasingame was the only human being in that house. For all we know here in this case, there could have been one dozen people in the house at the time, bearing in mind that the testimony of the witness, Clark, adds up to nothing in this case.

He testified that nothing happened at the time, and the Government was permitted to impeach him, and I would say he added nothing to their case.

The only other evidence is that Clark left the house, and that Blasingame was in the door when he left; that he came to the automobile in which the



police officers were, and they thereupon found the exhibit that has been admitted in evidence to substantiate Counts I and II. [225]

Now, there is no evidence that Blassingame is the man who gave the witness, Clark, the exhibit. There is no evidence that he sold him the exhibit. There is no evidence that Blassingame had possession of this.

It is undisputed in this case from the Government's own testimony that this house belonged to a woman who answered to the name of Chinkie Johnson.

Now circumstantially it would seem to me that it is just as inferrable that some other occupant in the house gave the exhibit to the witness Clark, or that the woman, Chinkie Johnson, who was in the house, brought it there. Certainly, no evidence in this case that he bought or obtained possession of this exhibit from the defendant Blassingame.

The Court: Mr. Roberts—are you going to speak on the same thing?

Mr. Chavelle: I was going to refer to my memorandum of authorities referring to sale and possession.

The Court: Mr. Roberts?

Mr. Roberts: If your Honor please.

The Court: As to Counts I and II only.

Mr. Roberts: While I readily agree that the case against the defendant on Counts I and II, is it?

Mr. Chavelle: Yes, sir. [226]

Mr. Roberts: Relating to May 29, 1956, are circumstantial, I feel there is an overwhelming amount

of evidence to go to the jury on the question, particularly in view of just some of the matters the jury can consider:

Officer Kirschner testifying that he was with Clark when a telephone call——

The Court (Interposing): There is no question but that I think circumstantial evidence would take it to the jury on the fact he acquired the narcotics or heroin, as covered in Exhibit No. 1, at that address.

Mr. Roberts: And from the defendant.

The Court: Well, how do you connect it with the defendant?

Mr. Roberts: Primarily because a call was made to Sam Blassingame, and that is who they went there to see, and that is who let Clark in the house, and that is who let Clark out of the house. Albeit there may have been someone else in the building at the time, that is a question for counsel to argue to the jury; but I also can argue.

The Court: I think there may be some basis for the motion. However, the Court will reserve ruling at this time, and we will proceed.

I might indicate I will probably reserve it until there is something very material in the evidence in the defendant's case, and probably reserve the ruling [227] until the time that the defendant's case is in.

Mr. Chavelle: That is without prejudice to our renewing our motion?

The Court: I don't deny it. I am merely reserving it.

Mr. Chavelle: I will ask the Court for a recess.

The Court: Yes. You will be ready with your opening statement when we reconvene?

Mr. Chavelle: Yes, we will.

The Court: All right. The Court will take a fifteen-minute recess.

(Whereupon, at 11:00 o'clock a.m., a recess was had in the within-entitled and numbered cause until 11:34 o'clock, a.m., January 16, 1957, at which time, counsel and the defendant heretofore noted being present, the following proceedings were had, to wit:)

The Court: You may call the jury.

(Whereupon, the jury was returned to the court room.)

The Court: You may be seated.

It is stipulated that the jury and the defendant are present in the court room?

Mr. Chavelle: So stipulated your, Honor. [228]

Mr. Roberts: So stipulated, your Honor.

The Court: You may proceed.

Mr. Kosher: Your Honor, Ladies and Gentlemen of the Jury, and counsel for the Government:

At this time it is my duty as co-defense counsel to outline to you in a very brief sort of way what the defense in this case will attempt to prove.

Our evidence will disclose that the defendant, Sam Blassingame, is a man thirty-three years of age; that he has been a construction worker, and that he

has worked in the shipyards, and, to a very small extent, he has done some commercial gambling.

The evidence will show that he is a married man, and the father of three children.

Our evidence will disclose that some time prior to May 29, 1956, Mr. Blassingame was separated from his wife, and they were living separately and apart. Some time prior to May 29, 1956, he rented a room at 231-23rd North. This house, the evidence will disclose, was owned by a lady by the name of Bernice Fitzgerald, who has a nickname of "Chink."

The evidence will disclose she is a colored lady, although she looks Oriental, and has picked up the nickname "Chink."

The evidence will show on May 29, 1956, [228a] Mr. Blassingame was not on these premises owned by Miss Fitzgerald, and that he did not possess any narcotics, nor did he sell any, nor give any away, nor did he dispense them, and that he had nothing whatever to do with the possession of any narcotics in the hands of Mr. Clark, the Government witness, and that he did not sell him any, or give him any, or receive any money from him.

With reference to Count III of this Indictment, the evidence will show on June 19, 1956, in this area known as 26th and East Thomas, that the defendant Blassingame was not there, and that he was not upon the landing of the stairway, and that he did not possess any narcotics on that date, nor did he dispense any.

The evidence will show that he was nowhere

around this area where the fire hydrant was supposed to be, and that he did not leave any narcotics there, and he did not have anything to do with any narcotics that may have been found there.

After all the evidence is in, Ladies and Gentlemen of the Jury, we will ask you to return a verdict of non guilty as to all counts as to this defendant, Sam Blassingame.

(Whereupon, there was a brief pause.)

Mr. Kosher: Take the witness stand. [229]

### SAM BLASSINGAME

upon being called as a witness for and on behalf of the defendant, and upon being first duly sworn, testified as follows:

#### Direct Examination

By Mr. Kosher:

Q. Will you state your name, please?

A. Sam Blassingame.

Q. And what is your residential address, Mr. Blassingame?      A. 118-25th North.

Q. And how old are you?      A. Thirty-three.

Q. And where have you worked in the past?

A. At the shipyards in Pasco, and I was up in Alaska for two years.

Q. And have you done some commercial gambling?      A. A little bit.

Q. Now, calling your attention to May 29, 1956, do you remember that date?      A. Yes.

Q. Were you married at that time?



(Testimony of Sam Blassingame.)

A. Yes, I was.

Q. And are you still married? [229a]

A. Yes.

Q. And what is your wife's name?

A. Maria.

Q. Do you have some children, Sam?

A. Three.

Q. How old are they?

A. Two, three and six.

Q. And on May 29, 1956, were you separated from your wife?      A. Yes.

Q. Now, calling your attention to some premises that are located at 231-23rd North, do you know where those premises are?      A. Yes.

Q. And what kind of a place is that?

A. It is a duplex.

Q. Did you ever reside at 231 North 23rd?

A. Yes.

Q. Now, on May 29, 1956, were you living there?

A. No.

Q. Now, on May 29, 1956, did you either sell or give any narcotics to a man by the name of Clark?

A. No.

Q. Or to any other person? [230]

Mr. Roberts: Pardon me, your Honor. I did not hear the witness' response to the question as to whether or not he resided at the premises on May 29, 1956.

The Witness: I did not.

Mr. Roberts: You did not?

The Witness: No.

(Testimony of Sam Blassingame.)

The Court: Keep your voice up, Mr. Blassingame, so that the jury and all counsel can hear you.

Q. (By Mr. Kosher, continuing): Did you sell or give or possess any narcotics on May 29, 1956?

A. I did not.

Q. Now, with reference to this area known as 26th and East Thomas, do you know where that is, Sam?

A. Yes.

Q. And when you were served with this indictment, did you go out and look at that area?

A. Yes.

Q. Did you find a fire plug out there?

A. Yes.

Q. Have you ever deposited or left any narcotics at that fire plug?

A. No.

Q. And did you do so on June 19, 1956?

A. I did not. [231]

Q. Now, do you know where the stairway is out there?

A. Yes.

Q. Were you ever on that landing on June 19, 1956?

A. I was not.

Mr. Kosher: Excuse me a minute.

(Whereupon, there was a brief pause.)

Q. (By Mr. Kosher): Now, do you recognize the gentleman who answered to the name of Kirschner here in court?

A. Yes.

Q. Now, do you remember seeing him some time in October of this year—of last year, I mean?

A. I remember seeing him, but just the exact date or month, I don't know.

(Testimony of Sam Blassingame.)

Q. Now, did you ever have a conversation with him with reference to this case?      A. No.

Q. Did he ever discuss this case with you?

A. Never.

Q. Or did you ever discuss the case with him?

A. No.

Q. Now, he testified here that you told him that the only person that could have made you, or fixed you, or words to that effect, was a man by the name of Clark.

Did you ever make any such statement? [232]

A. I did not.

Q. Did you ever discuss a man by the name of Clark with him?      A. No.

Mr. Kosher: You may inquire.

Mr. Roberts: Is that all, counsel?

Mr. Kosher: Yes.

### Cross-Examination

By Mr. Roberts:

Q. Sam, when did you work in the shipyards?

A. From 1942 until 1948.

Q. From 1948 until you got busted in September, 1956, where did you work?

Mr. Chavelle: I object to the word "busted."

Mr. Kosher: I object to the word "busted."

Mr. Roberts: Pardon me, your Honor—

The Court (Interposing): Objection sustained.

Mr. Roberts (Continuing): The witness was about to answer the question.

(Testimony of Sam Blassingame.)

The Court: Well, I don't know what the word "busted" means.

Mr. Roberts: The witness may, your Honor.

The Court: I will sustain the objection. [233]

Q. (By Mr. Roberts, continuing): What does "busted" mean, Sam?

Mr. Kosher: I will object on the grounds it is immaterial.

The Court: Objection sustained.

Q. (By Mr. Roberts, continuing): Where did you work between 1948 and September, 1956?

A. I worked in Pasco from 1948 until 1951.

Q. What did you do in Pasco?

A. Construction work.

Q. With what company?

A. Marsh and Knutson Construction.

Q. From 1951 on, what did you do?

A. I was in Alaska for two years.

Q. Doing what? A. I was a bartender.

Q. Where in Alaska? A. Fairbanks.

Q. What particular establishment?

A. Old Aces.

Q. What is it?

A. A club by the name of Old Aces.

Q. And that was for two years, is that right?

A. Yes. [234]

Q. And that would be from 1951 through 1953, or thereabouts? A. Something like that.

Q. You were in Alaska during that time; all right, where did you next work?

A. In Yakima and Moses Lake.

(Testimony of Sam Blassingame.)

Q. Were you working steadily throughout these years?  
A. No.

Q. Well, how long did you work?

A. Throughout which years?

Q. Pardon me?

A. I was working steady from 1942 until 1948 in the shipyards.

Q. All right. Then sporadically from 1948 through September of 1956, is that right?

A. Well, I worked two years in Alaska. I worked in Pasco.

Q. When did you work in Pasco?

A. It was in 1948, the last of 1948.

Q. Do you recall being interviewed by Federal Narcotics Agent Charles Fahey on September 28, 1956, just after you had been arrested, and your interview took place in the King County Jail, and his asking you where you had been recently working?

A. I remember Charlie Fahey coming up to talk to me [235] when I was in the city jail; and he asked me, and I went to talk to him, about any stuff, and I told him I didn't know anything about any stuff; and he said, "That is all."

Q. What do you mean by "stuff"?

A. Just what he said. I don't know what he meant about stuff, or whatever stuff he was talking about.

Q. You don't know what "stuff" is, is that right?  
A. No.



(Testimony of Sam Blassingame.)

Q. Do you recall Mr. Fahey asking where you had been working recently?      A. No.

Q. Do you recall telling him you had not worked since 1948 or 1949, and you couldn't recall which?

A. No, he didn't ask me that.

Q. You worked—did you work as a gambler in 1948 or '9, '50, '1, '2, '3, '4 or '5—any of those years?

A. I haven't worked as a gambler. I have gambled.

Q. Did you ever win a Cadillac gambling?

A. Did I ever win a Cadillac?

Q. Yes.

Mr. Kosher: I object to that on the grounds it is immaterial.

The Court: Objection overruled.

Q. (By Mr. Roberts, continuing): A Cadillac, Sam? [236]

A. I have never owned a Cadillac.

Q. I said, did you ever win one gambling?

A. I have never owned one.

The Court: The question is, did you ever win one?

The Witness: No.

Q. (By Mr. Roberts): Now, when did you live at 231-23rd North in this city?

A. I believe it was in January or February in 1956.

Q. Of 1956?      A. Yes.

Q. And you testified that you were not living there on May 29, 1956?      A. I was not.

(Testimony of Sam Blassingame.)

Q. Were you at the apartment that night?

A. No.

Q. Where were you that night?

A. On 118-25th North.

Q. When did you move into 118-25th North?

A. I don't know the exact date.

Q. Before May of 1956? A. Yes.

Q. On October 3, 1956, you were living at 118-25th North, were you not? [237]

The Court: What date? Will you repeat that question?

Mr. Roberts: Yes, your Honor.

I have asked the question:

Q. (By Mr. Roberts, continuing): Is it not a fact that on October 3rd of 1956 you were living at 118-25th North? A. Yes.

Q. At that time you apparently just had a rug on the floor, is that right?

A. Apparently had what?

Q. Just a rug on the floor, little or no furniture?

A. On which floor?

Q. On the front-door floor, it would be on.

A. Yes, on the front; there was a rug on the front at the front door.

Q. Were there any chairs around in there?

A. I don't think so.

Q. So, how did you get along from before May until October with no furniture?

A. From when?

Q. From when you first moved in there?

A. I had furniture when I first moved in there.

(Testimony of Sam Blassingame.)

Q. And you lost the furniture, is that right?

A. That is right. [238]

Q. Who is Chinkie Johnson?

A. Bernice Fitzgerald.

Q. Is she a friend of yours? A. Yes, sir.

Q. Counsel has suggested in some questions that she is a prostitute. Is she?

A. I wouldn't know.

Q. Pardon me? A. I wouldn't know.

Q. You don't know whether or not she is?

A. I don't know.

Q. Is she a girl friend of yours?

A. She was at one time.

Q. You and your wife were separated during May and June, 1956, were you not? A. Yes.

Q. She was down in Portland, Oregon, at that time, was she not? A. Yes.

Q. As a matter of fact, you were still separated when you were arrested in September, 1956?

A. That is right.

Q. Isn't that correct? Are you actually back together now? A. No. [239]

Q. Do you know Johnny Clark? A. Yes.

Q. How did you come to know Johnny?

A. Through gambling.

Q. Pardon me? A. Through gambling.

Q. Through gambling; do you associate with him very much? A. Yes.

Q. You knew he was a drug addict, then?

A. I couldn't swear that he were, no.

Q. Pardon me?

(Testimony of Sam Blassingame.)

A. I couldn't swear he used drugs, or not.

Q. Do you know Wally Hanks? A. Yes.

Q. You knew he was in the drug business?

A. I don't know.

Q. Do you know Mary Childress?

Mr. Kosher: Object to that on the grounds it is immaterial.

The Court: It would appear to be.

Mr. Roberts: It shows his association, if your Honor please, with other individuals.

The Court: Well, I don't know on what issue. I am inclined to sustain the objection unless [240] you want to make an offer of some kind.

Mr. Roberts: I don't believe it is necessary, your Honor; I will withdraw the question.

The Court: All right.

Q. (By Mr. Roberts, continuing): As I understand it, you deny ever having a conversation which Officer Kirschner has testified he had with you on October 3, 1956, is that right?

A. Deny what, now?

Q. You never had that conversation with Mr. Kirschner?

A. Never had no conversation with Kirschner when?

Q. On October 3, 1956, in your apartment at 118-25th Avenue North?

A. I have talked to him on—yes, I talked to him.

Q. Well, I understood you to say that you did not talk with him at that time?

A. About what?

(Testimony of Sam Blassingame.)

Q. Did you talk to him? A. About what?

Q. About narcotics.

A. No; I didn't talk to him about no narcotics.

Q. All right; what led to that meeting? How did you two meet together?

A. When I was living on 15th, which was——

Q. (Interposing): I am referring to October 3, 1956. [241]

A. If you let me, I will get around to that.

Q. All right.

A. When I was living on 15th, I had a Collie, and she had some pups, and he wanted one, but at the present time I have got rid of all of them, and I didn't get around to—in other words, he didn't get one.

Q. Was Mr. Kirschner a friend of yours?

A. How is that?

Q. Is he a friend of yours?

A. No; I wouldn't say he is a friend of mine. I know him.

Q. You have known him for some years?

A. Yes.

Q. How did he happen to know you had some Collie pups?

A. How did he know? Evidently he saw them.

Q. Well, is that why he came to your apartment on October 3, 1956? A. No.

Q. Do you remember him coming to your apartment at that time? A. Yes.

Q. What did you talk about?

A. We talked about the dog.



(Testimony of Sam Blassingame.)

Q. About the dog? [242] A. Yes.

Q. And that is all you talked about?

A. That is all.

Q. And at that time did you just have a rug inside the door, and no furniture in the place?

A. There was furniture in the place, every place other than there, the living room; there was no furniture in the living room, no.

Mr. Roberts: I have no further questions, your Honor.

Redirect Examination

By Mr. Kosher:

Q. Did this police officer want you to give him a Collie dog, Sam?

A. No; I don't think so. In fact, I didn't even know if he wanted one at this particular time, but he had asked me about one once before.

I had no intention of giving it to him, but if he wanted to buy one, I would sell it.

Q. And he did discuss the possibility of getting a Collie dog from you? A. Yes.

Q. Now, Sam, I didn't ask you this:

Do you use narcotics yourself? [243]

A. No.

Q. Have you ever used any narcotics?

A. No.

Mr. Kosher: That is all.

Mr. Roberts: I have nothing further.

Mr. Chavelle: That is all, Sam.

(Witness excused.)

The Court: Do you have any other witnesses you want to get on, or do you want to recess?

Mr. Chavelle: A recess, if your Honor please.

The Court: All right; we will recess until [244] 1:45.

\* \* \*

### ALLEN CLAIBORNE

upon being called as a witness for and on behalf of the defendant, and upon being first duly sworn, testified as follows:

The Clerk: Will you state your full name and spell your last name, please?

The Witness: Allen Clairborne, A-l-l-e-n C-l-a-i-b-o-r-n-e (spelling).

### Direct Examination

By Mr. Chavelle:

Q. Your name is what, again?

A. Allen Claiborne.

Q. Where do you reside?

A. 1018-9th Avenue.

Q. What is your occupation?

A. Private detective.

Q. How long have you been a private detective?

A. I have been a detective for 26 years, of which 20 years in the private field.

Q. You are licensed under the laws of the State of Washington? A. Of the City of Seattle.

Q. Of the City of Seattle; I will ask you if you are familiar with the intersection known as 26th and East [250] Thomas in Seattle? A. I am.

(Testimony of Allen Claiborne.)

Q. Have you had occasion to visit that area?

A. Yes.

Q. How often have you been there?

A. Four times.

Q. Within what period of time in relation to this case?

A. The first time was December 30, and the second and third times were on January 3rd, and the last time was today.

Q. I will ask you if you have been there in the night time?           A. I have; twice.

Q. What dates were you there at night?

A. December 30th and January 3rd.

Q. At what hour of the night on December 3rd, do you recall?           A. About 6:20 p.m.

Q. Or on January 3rd?           A. 6:00 p.m.

Q. Can you describe the stairway there?

A. Yes; there is a stairway that is a continuation of East Thomas Street, and runs from 26th up to Madison, and it has two landings, one about one-third of the way up, [251] and another about two-thirds of the way up.

Q. Approximately what is the length of that stairway, do you know?           A. About 90 feet.

Q. What is the condition of the lighting there at night?

A. At the bottom of the stairway, which comes right into the intersection of East Thomas, to the north of the north edge of the sidewalk, there is a utility pole with a dim, incandescent bulb.

## C. F. KIRSCHNER

upon being recalled as a witness for and on behalf of the defendant, and having been previously duly sworn, testified as follows:

## Direct Examination

By Mr. Chavelle:

Q. You have already been sworn, and you testified in this cause, haven't you, Officer?

A. That is right.

Q. Your name is Officer Kirschner?

A. C. F. Kirschner.

Q. Of the Seattle Police Department?

A. Yes.

Q. Are you familiar with the stairway at 26th and East Thomas Street in the City of Seattle?

A. Yes; I am.

Q. Were you familiar with it on June 19, 1956?

A. Yes.

Q. Have you seen it since?           A. Yes.

Q. Has there been any material change in that stairway?           A. No; there has not been.

Q. Pardon? [255]

A. No; there has been no change.

Q. Any change in the lighting, to your knowledge?           A. No.

Q. At the time you testified as to the date of June 19th, 1956, was it dark?

A. It was dark, yes. It was nighttime.

The Court: Do you recall whether there was moonlight, or raining?

The Witness: It was a clear night. It wasn't

(Testimony of C. F. Kirschner.)

raining. I don't recall if the moon was out or not.

The Court: It was dark?

The Witness: It was dark, yes.

Mr. Chavelle: I think that lays sufficient foundation.

Mr. Roberts: I would consider that sufficient foundation, your Honor.

Mr. Chavelle: Thank you, Mr. Kirschner.

The Court: You have no questions?

Mr. Roberts: No.

(Witness excused.)

Mr. Chavelle: Mr. Claiborne. [256]

### ALLEN CLAIBORNE

upon being recalled as a witness for and on behalf of the plaintiff, and having been previously duly sworn, testified as follows:

#### Direct Examination

(Continued)

By Mr. Chavelle:

Q. Now, Mr. Claiborne, it has been established by another witness that the stairway has not been changed, and that conditions are similar.

I will ask you if you caused an experiment to be made December 30th and January 3rd of this past couple months as to visibility of persons situated on a stairway; what time it was, and give us all the facts and circumstances concerning the experiment?

A. On December 30th between 6:20 to 6:50 p.m., I had you stand on the top level and on the bottom



(Testimony of Allen Claiborne.)

A. This is a photograph taken from the east side of 26th, showing——

Mr. Roberts: I will object, your Honor, to any further testimony as to what the photograph is, until there is more proper foundation as to who took the photograph.

I don't mean to impede you, counsel. If you want to ask who took the photograph——

Mr. Chavelle (Interposing): I was going to ask that, and what it represented, first.

Q. (By Mr. Chavelle): Now, when was that taken? A. On the night of January 3rd.

Q. And by whom?

A. By a professional photographer, Earl Penninger.

Q. And under your supervision and direction?

A. Under my supervision and direction.

Q. And were you present at the time of the taking of the picture? A. I was.

Q. And does that truly portray what that picture is intended to represent?

A. It does. [260]

Q. What time was that picture taken?

A. About 6:15 p.m.

Q. And what position was the photographer in when he took that picture, in relation to the stairway?

A. He was on the east side of 26th Avenue, where Thomas comes in.

Q. How many feet would that be from the bottom of the stairway?

(Testimony of Allen Claiborne.)

A. That would be about forty feet.

Q. Approximately 40 feet? A. Yes.

Q. And how far were you away? I will ask you that. Who is in that picture? A. The——

Mr. Roberts (Interposing): I will object, your Honor.

The Court: Have you seen it?

Mr. Roberts: No. I would like to take a look at it, your Honor.

Once again, I do not want to slow up the proceedings.

May I inquire on voir dire, your Honor?

The Court: You may.

Mr. Roberts: What was the shutter speed at the time the picture was taken? [261]

The Witness: I don't know. I didn't shoot it.

Mr. Roberts: What was the action?

The Witness: He asked me if I wanted normal lens opening, and I said yes.

Mr. Roberts: Do you know what the aperture was?

The Witness: I don't.

Mr. Roberts: What type of film was used?

The Witness: I am no photographic expert.

Mr. Roberts: Even though I don't believe there is any foundation laid, your Honor, I will stipulate that this may be offered in evidence.

Mr. Chavelle: No objection? We will offer it, your Honor.

The Court: All right. May I see it?

(Testimony of Allen Claiborne.)

All right. Defendant's Exhibit No. 1-A may be admitted. A-1, rather.

(Defendant's Exhibit No. A-1 admitted in evidence.)

(Whereupon, there was a brief pause.)

Mr. Roberts: I have no objection to this photograph.

The Clerk: Defendant's Exhibit Number A-2 for identification. [262]

(Defendant's Exhibit No. A-2 marked for identification.)

The Court: Exhibit A-2.

Mr. Roberts: Being admitted, your Honor.

The Court: All right; Exhibit No. A-2 may be admitted.

(Defendant's Exhibit No. A-2 admitted in evidence.)

Mr. Roberts: May I inquire as to the date these were taken?

The Witness: January 3rd.

Mr. Roberts: Of this year?

The Witness: Yes.

Mr. Roberts: 1957.

Q. (By Mr. Chavelle): Approximately how far—what distance is the alley from the bottom of the stairway?

A. Well, it is a standard city block. That would give it about 120 feet to the alley.

(Testimony of Allen Claiborne.)

Q. From the bottom of the stairway?

A. No; from the east curb. About 160 feet from the bottom of the stairway.

Q. 160 feet from the bottom of the stairway?

A. Yes.

Mr. Chavelle: You may inquire. [263]

Mr. Roberts: Thank you.

Cross-Examination

By Mr. Roberts:

Q. Mr. Claiborne, you have studied this intersection, and maybe you can clarify all our minds as to what it looks like.

What direction does 26th Avenue proceed through the intersection, if it does?

A. It doesn't go through. It is a dead end.

Q. Will you describe it to us as vividly as you can?

A. Yes. 26th, running from John to Thomas, is a standard city block running approximately north and south.

Q. 26th Avenue goes to the south from the intersection of 26th and Thomas, but it doesn't go through to the north?      A. That is true.

Q. And isn't it true that Thomas goes to the east?

A. Dead-ends to the west, at the west.

Q. And goes down hill?      A. Yes.

Q. But doesn't go to the west?      A. No.

Q. On the west we have a bank or a hillside, with the steps on it? [264]      A. Yes.

(Testimony of Allen Claiborne.)

Q. And you estimate the length of the steps about 90 feet?      A. Approximately.

Q. Did you actually get a tape out?

A. No.

Q. Now, as these photographs describe, there are some sodium vapor lights on Madison Street above?      A. That is right.

Q. Did you attempt to determine whether you can stand at the base of the stairs and see an automobile on the curb of Madison Street?

A. Oh, yes; on Madison Street you can see cars go by.

Q. You can see?

A. Colors, well, it is always as under sodium vapor, a light green shows up as blue.

Q. On the south side of Thomas Street, as you go out of the intersection down the hill, there are some homes?      A. Yes.

Q. And the yards there in those homes are more or less terraced as they go up to the intersection?

A. Yes.

Q. They have tried to level them off, and terrace one into the other; is that correct?

A. Yes. [265]

Q. And your principle testimony here is that the last house facing Thomas Street is pretty close to the corner?      A. Yes.

Q. Isn't it a fact that the yard of that house is what we call sub-grade, or below grade on the street?      A. That is true.



(Testimony of Allen Claiborne.)

Q. It is down and sunken, isn't it?

A. Yes.

Q. So that if you were standing on the sidewalk at 26th and just about to turn the corner and go down Thomas Street to your right, and you looked at this house, between where you are standing on the sidewalk and that house, there would be a hill rolling off, wouldn't there?      A. That is true.

Q. And that isn't really a putting green lawn on that hill, is it?

A. You mean in front of that corner house?

Q. I mean on that little house right off the sidewalk.

A. I am not a golfer. Explain what a putting green is.

Q. A nice lawn?

A. No; I wouldn't say it is rolled.

Q. Well, there it is a very poor grass, tangled type [266] of thing, isn't it?

A. I didn't examine the lawn.

Q. Also, on the parking strip, if you were standing on that sidewalk looking down?

A. There is a parking strip on both sides.

Q. Toward your left, towards the intersection?

A. Yes.

Q. Where that fire hydrant is located?

A. Yes.

Q. And that isn't a putting green lawn?

A. It is green.

Q. It is grass?      A. It is grass, and green.

Q. But it is pretty coarse grass?

(Testimony of Allen Claiborne.)

A. It is not very high.

Q. You looked at it today, didn't you?

A. Yes.

Q. It is not green today?

A. Yes; it is green. I laid down on it.

Q. I looked at it last night myself, and it looked a little brown to me.

Mr. Kosher: Just a minute. I object to counsel's statement.

The Court: It may be stricken.

Mr. Roberts: I will strike the question. [267]

The Court: And the jury will disregard it.

Mr. Kosher: And I move for a mistrial at this time, if your Honor pleases.

The Court: Motion will be denied. The jury will disregard the statement of counsel, referring to the statement of Mr. Roberts.

You may proceed, Mr. Roberts.

Q. (By Mr. Roberts, continuing): Now, in any event, the grass has been cut down along the fire hydrant and parking strip?

A. The parking strips have been mowed.

Q. Once again, now, to get a picture of the intersection in mind, at the base of the stairs leading up from the intersection to Madison, there is a sidewalk between the base of the stairs and the street, is there not?      A. True.

Q. How wide is that?      A. About five feet.

Q. And then if you go——

A. (Interposing): And also a parking strip.

Q. Yes, that is correct, and if you go a little to

(Testimony of Allen Claiborne.)

the south from the base of the steps, you will have then the street going across. That would be 26th Avenue North?           A. Yes.

Q. How wide is the street?

A. 32 feet. [268]

Q. Pardon me?           A. 32 feet, I would say.

Q. 32 feet, yes, and how wide is the parking strip at the point of the fire hydrant from the street?

A. About three feet.

Q. So that you have three feet plus sixty feet; what is the total distance from the fireplug, then, to the base of the stairs?

A. You are giving me too many figures. What was the last part of the question? What would be the total distance from the fireplug to the base of the stairs?

Q. What would be the total distance from the fireplug to the base of the stairs?

A. Fireplug to base of stairs, about forty feet.

Q. I thought the street was 60 feet?

A. No; about 32 feet.

Q. Forty feet is the estimate; all right.

Now, at the time you took these photographs, did you have anyone parking his car just under the brow of the hill on Thomas Street, and turn the headlight on the steps to see if you could recognize anyone coming down there?           A. No.

Q. At the time you made these experiments, did you have anyone stand at the fireplug while you put yourself in the yard of the last house on Thomas Street, apparently right [269] over the roll of the

(Testimony of Allen Claiborne.)

hill? A. On the corner of 26th, no.

Q. Did you see if you could recognize anybody?

A. No.

Q. What would be the distance from the edge of the kept yard in that last house to the fire hydrant?

A. If you are in the yard, you have about an eight-foot embankment.

Q. That is right; now, what would be the distance?

A. Well, you have got about a 50-foot lot there.

Q. And you are in the extremity of the end toward that embankment?

A. Probably twenty-five to thirty feet.

Q. Well, does the house extend over the yard? I don't mean to confuse you, but you testified earlier you thought the distance from the fireplug to the house was about 15 feet.

A. To the house?

Q. Yes.

A. That would be—yes, I guess it would be, to the carport, about 15 to 20 feet.

Q. So that if you were standing in the yard you would be about that far from the fireplug, apparently? A. Yes.

Q. And you didn't try that experiment? [270]

A. No, I did not.

Mr. Roberts: I have no further questions, your Honor.

Mr. Chavelle: No further questions, your Honor. May this witness be excused?

(Testimony of Allen Claiborne.)

The Court: Yes; I assume there is no reason to keep him, Mr. Roberts?

Mr. Roberts: I have no objection.

The Court: You may be excused from further attendance, Mr. Claiborne.

(Witness excused.)

Mr. Chavelle: If the Court please, the defense rests at this time.

The Court: All right.

Mr. Chavelle: We would like to make a motion.

The Court: Do you wish to make the same motion you made before?

If agreeable with you, the Court will consider they are made as though made now, and will reserve ruling.

Mr. Chavelle: All right.

The Court: Is that agreeable?

Mr. Chavelle: Yes. [271]

\* \* \*

### Reporter's Certificate

I, Earl V. Halvorson, official court reporter for the United States District Court, Eastern and Western Districts of Washington, do hereby certify that the foregoing is a true and correct transcript of the proceedings had in the within-entitled and numbered cause on the date hereinbefore set forth; and I do further certify that the foregoing transcript has been prepared by me or under my direction.

/s/ EARL V. HALVORSON. [361]



In the United States Court of Appeals  
for the Ninth Circuit  
No. 15430

SAM BLASSINGAME,

Appellant,

vs.

UNITED STATES OF AMERICA,

Appellee.

STATEMENT OF POINTS UPON  
WHICH APPELLANT WILL RELY

Comes Now the Appellant, Sam Blassingame, and herewith sets forth the points upon which he will rely in the appeal of the above-entitled action:

1. The District Court erred in denying defendant's motion for dismissal of Counts I and II of the Indictment, and allowing the jury to consider the evidence adduced in support of said counts.

2. The evidence adduced by the Government in support of the Indictment was insufficient to take the case to the jury, or to support the verdict and/or judgment upon the charge contained in the indictment.

3. The District Court erred in denying the defendant's motions for mistrial.

CORNELIUS CHAVELLE,

MAX KOSHER,

JOHN N. LEAVITT,

Attorneys for Appellant;

By /s/ JOHN N. LEAVITT.

[Title of Court of Appeals and Cause.]

AMENDED DESIGNATION OR  
RECORD UPON APPEAL

Comes Now the defendant and appellant herein,  
Sam Blassingame, and designates the following as  
Appellant's Record Upon Appeal:

1. Indictment.
2. Verdict of the Jury.
3. Notice of Appeal.
4. Judgment and Sentence.
5. Motion in Arrest of Judgment.
6. Testimony of the following-named witnesses:
  - (a) Chester G. Sprinkle,
  - (b) Laverne E. Gooder,
  - (c) Charles Fahey,
  - (d) Johnny Clark,
  - (e) Charles F. Du Puis,
  - (f) C. F. Kirschner,
  - (g) William E. Henaby,
  - (h) Robert W. Waitt,
  - (i) Sam Blassingame,
  - (j) Allen Claiborne.

CORNELIUS CHAVELLE,  
MAX KOSHER,  
JOHN N. LEAVITT,  
Attorneys for Appellant.

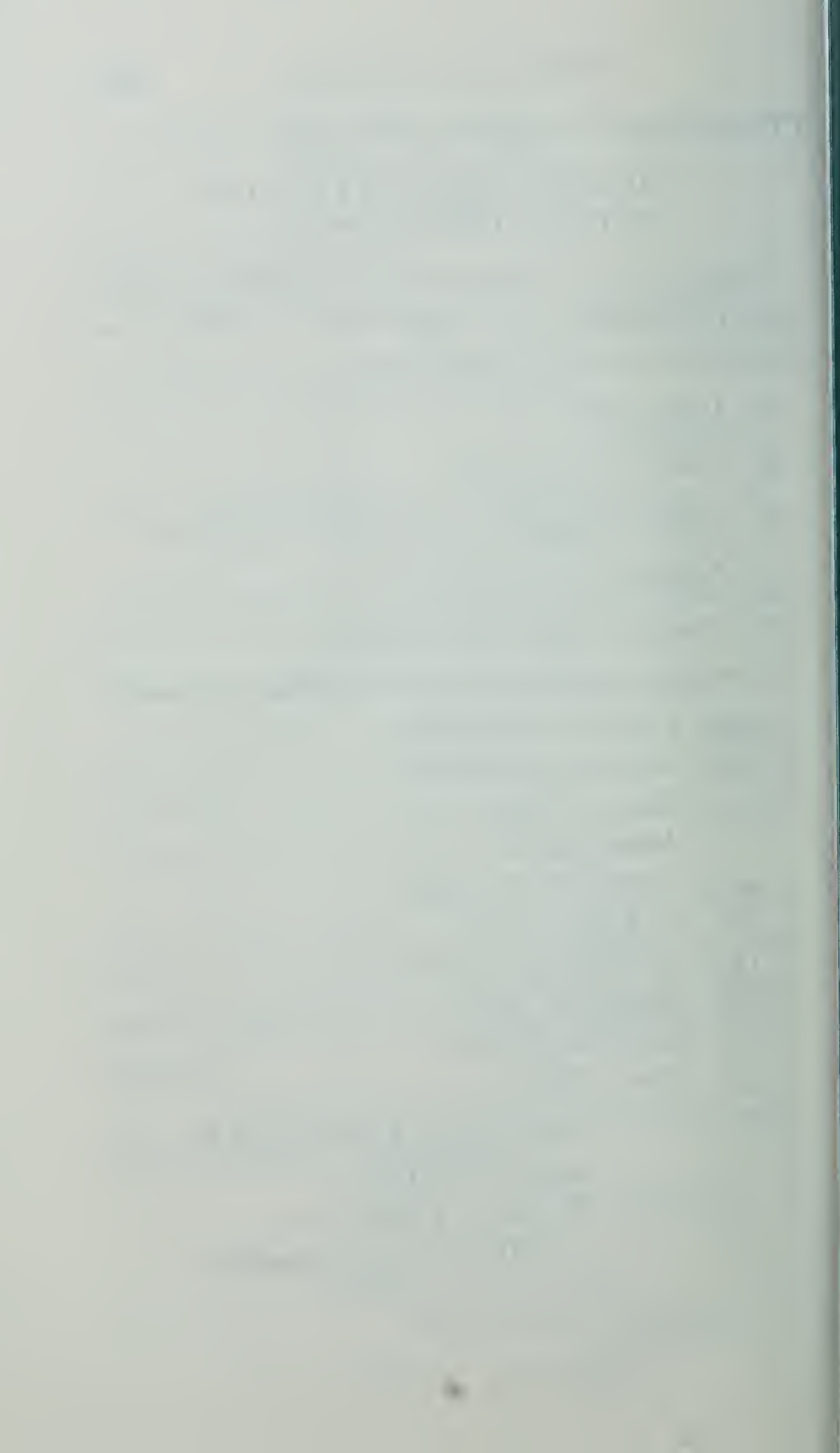

No. 15,430

United States Court of Appeals  
For the Ninth Circuit

---

SAM BLASSINGAME,

*Appellant,*

vs.

UNITED STATES OF AMERICA,

*Appellee.*

Appeal from United States District Court for the Western  
District of Washington, Northern Division, No. 49,488.

BRIEF FOR APPELLANT.

---

BENJAMIN M. DAVIS,

JAMES W. FUNSTEN,

479 Flood Building,

San Francisco 3, California,

*Attorneys for Appellant.*

FILED

DEC 27 1957

PAUL P. WELLEN, CLERK





## Subject Index

---

	Page
Statement of jurisdiction .....	1
Summary of the case .....	2
Specification of error .....	5
Argument of the case .....	10

### I.

That the District Court erred in not granting judgment of acquittal upon Counts I and II .....	12
--	----

### II.

That there was error of the court and misconduct of the United States Attorney in relation to the testimony of Johnny Clark .....	17
---	----

### III.

That the errors regarding evidence above set out and the denial of judgment of acquittal affected the determination of Counts III and IV .....	27
--	----

### IV.

That the evidence adduced under Counts III and IV was not sufficient upon which to base a verdict of guilty ...	28
---	----

### V.

That had there been no prejudicial error and had the matters under Counts I and II not been submitted to the jury, the jury might well have found a verdict of not guilty upon Counts III and IV .....	32
Conclusion .....	33

## Table of Authorities Cited

---

Cases	Pages
Altieri v. Public Service Ry. Co., 103 N.J.L. 351, 93 N.H. 250, 135 Atl. 786 .....	21
Apodaca v. United States, 5th Cir., 200 F. 2d 775 .....	25
Colby v. Avery, 40 Atl. 2d 841 .....	21
Culwell v. United States, 5th Cir., 194 F. 2d 808 .....	25
Dawson et al. v. United States, 9th Cir., 10 F. 2d 106, cert. den. 271 U.S. 687, 70 L. Ed. 1152, 46 S. Ct. 638 .....	18
Eng Jung v. United States, 3rd Cir., 46 F. 2d 66 .....	16, 32
Forrester v. United States, 5th Cir., 210 F. 2d 923 .....	25
Grantello v. United States, 8th Cir., 3 F. 2d 117 .....	27, 32
Hoagland v. Canfield, 160 Fed. 146 .....	21
Kuhn v. United States, 9th Cir., 24 F. 2d 910 .....	25
Little v. United States, 10th Cir., 73 F.2d 861 .....	33
Mitrovich v. United States, 9th Cir., 15 F. 2d 163 .....	18
Remmer v. United States, 9th Cir., 205 F. 2d 277 .....	17
Sousa v. United States, 9th Cir., 5 F. 2d 9 .....	18
State v. Thorne, 260 P. 2d 331, 43 Wash. 2d 47 .....	25
Terzo v. United States, 8th Cir., 9 F. 2d 357 .....	18
United States v. Bianco, D.C. Pa., 103 F. Supp. 867 .....	15
United States v. Bozza, 3rd Cir., 155 F. 2d 592 .....	15
United States v. Goldstein, 2nd Cir., 168 F. 2d 666 .....	14
United States v. Groves, 2nd Cir., 122 F. 2d 87 .....	16
United States v. Koch, et al., 2nd Cir., 113 F. 2d 982 .....	15, 16
United States v. Smith, 2nd Cir., 112 F. 2d 83 .....	16
Verro v. United States, 3rd Cir., 95 F. 2d 504 .....	18
Young v. United States, 5th Cir., 97 F. 2d 200, 117 A.L.R. 316 .....	24, 25

TABLE OF AUTHORITIES CITED

**Codes**

	Pages
21 U.S.C., Section 174 .....	1, 2, 11
26 U.S.C.:	
Section 4704(a) .....	1, 2, 11
Section 4705(a) .....	2, 11
28 U.S.C., Section 1291 .....	2

**Rules**

Federal Rules of Criminal Procedure:	
Rule 29 .....	14
Rule 29(a) .....	14
Rule 29(b) .....	14

**Texts**

Cyclopedia of Federal Procedure, 3rd Ed., Section 48.193 ..	15
McCormick, Evidence, Section 36 at p. 67 .....	20
Verdict in Federal Criminal Cases by Lester B. Orfield, Member of the United States Supreme Court Advisory Committee on Rules of Criminal Procedure, 16 Univ. of Pittsburgh Law Review 101, 115 .....	15

United States Court of Appeals  
for the District of Columbia

Case No. 10-1234

Filed: 10/26/2010

Plaintiff: ABC Corporation

Defendant: DEF Corporation

Case No. 10-1234

Plaintiff: ABC Corporation

Defendant: DEF Corporation

Case No. 10-1234

No. 15,430

**United States Court of Appeals  
For the Ninth Circuit**

---

SAM BLASSINGAME,

vs.

UNITED STATES OF AMERICA,

*Appellant,*

*Appellee.*

Appeal from United States District Court for the Western  
District of Washington, Northern Division, No. 49,488.

**BRIEF FOR APPELLANT.**

---

**STATEMENT OF JURISDICTION.**

Appellant was convicted in the United States District Court, Western District of Washington, Northern Division, upon two counts of violation of the Federal Narcotic Laws, in particular of violation of Section 174, Title 21, U.S.C., and Section 4704(a), Title 26, U.S.C. (R 4, 5). Judgment was rendered on January 28, 1957, sentencing appellant to five years imprisonment upon each count, the sentences to run consecutively, and imposing a fine upon the appellant (R 7, 8).

Notice of appeal was filed on January 29, 1957 (R 9).



Counsel for appellant submit that this Honorable Court has jurisdiction to hear this appeal from the judgment of the District Court by virtue of provisions of Section 1291, Title 28, U.S.C., which provides:

The courts of appeals shall have jurisdiction of appeals from all final decisions of the district courts of the United States, . . . except where a direct review may be had in the Supreme Court.

Counsel submit that this is not a case wherein a direct appeal to the Supreme Court of the United States may be had.

---

#### **SUMMARY OF THE CASE.**

The Indictment charged the appellant in four counts with violations of the Federal Narcotic Laws. Counts I and II charged violation on May 29, 1956 of Section 174, Title 21, U.S.C. and Section 4705(a), Title 26, U.S.C. Counts III and IV charged violation on June 19, 1956 of Section 174, Title 21, U.S.C. and Section 4704(a), Title 26, U.S.C.

As evidence to prove the charges under Counts I and II the prosecution introduced the testimony of federal and state narcotic enforcement officers which was to the effect that an informer, one Johnny Clark, under their surveillance and cooperating with them, obtained narcotics at a residential building, which narcotics did not bear the appropriate revenue stamps. Apparently, the officers had neither ever been in the building, nor kept the building under surveil-

lance. The evidence shows that at least two persons other than the informer and a person alleged to have been the defendant were present in the building. There is no testimony as to what went on in the building, and there is no testimony tending to connect the defendant with narcotics, excepting testimony that the defendant admitted the informer into the building and let him out and excepting testimony that the defendant by telephone permitted the informer to come see him. Motion to dismiss, treated as a motion for Judgment of Acquittal was made at the conclusion of the prosecution's evidence and at the conclusion of the defense but at both times ruling was reserved by the Court. The jury found the defendant not guilty upon these counts. Counsel contends that submission of them to the jury was prejudicial to the determination of Counts III and IV.

The prosecution called the alleged informer, Johnny Clark, as a witness; however, after a very few questions bearing upon the charges of Counts I and II, the prosecution claimed surprise by his testimony, which failed to support the prosecution's case. The Court ruled that there was surprise on the part of the prosecution. Counsel contends that in order that there be a right to impeach there must have been affirmative hostile testimony.

There was lengthy cross-examination of the witness and a reading of an alleged prior inconsistent statement, all of which, counsel submits, went far beyond any purpose of explaining the reason for which he was called and attacking his credibility upon those

questions to which the answers were claimed to be a surprise. One of these questions was whether the witness was presently charged with murder in the state Court, and another carried the inference that the witness, prior to the date stated in Counts I and II had received narcotics from the defendant. A mistrial was requested after both of those questions. Counsel for the appellant contends that right to claim surprise, if it existed, was misused by the prosecution to present material which was highly prejudicial and inadmissible and not justified on the grounds of surprise.

Counts III and IV charged unlawful acts on June 19, 1956. There was repeated testimony that before any action was taken that day there was a conference with the same Johnny Clark, a witness under Counts I and II. Counsel contends that this testimony made a direct relation between the error in the proof of Counts I and II, and the verdict in Counts III and IV. The testimony as to June 19, 1956 was that after the conference, three narcotics enforcement officers raced to a certain darkened intersection. Testimony then is that they searched around a fireplug at that intersection, then drove downhill away from the intersection sixty feet and parked; that one of them drew the attention of the others to a figure upon some stairs leading away from the intersection; that then two of them got out of the car and went up the hill, but that the other agent rolled the car down the hill, turned it around, and drove it up the hill with the lights on; that the figure stopped over the fire plug; that all

three officers saw him in the lights of the car back upon the stairs going away but looking back, and that he was the defendant; that he continued up to the top of the stairs where he paced for thirty seconds, but he was not pursued beyond the intersection; that narcotics were found at the fire plug; and that thereafter a man other than the defendant was arrested at the intersection. The testimony is conflicting as to why the defendant was not arrested on the evening in question, nor until three months later. Counsel for the appellant raises the question of whether the evidence was sufficient to send this case to the jury, and in particular, whether reasonable minds must not find, believing all the evidence of the prosecution, that another person, other than the person testified to be defendant could have left the package at the fire plug in the interval while the officers were parked down the hill.

Counsel further submits that it is open to doubt how the jury would have determined if the evidence under Counts I and II had been presented without error, or had been excluded from the jury's final consideration.

---

#### **SPECIFICATION OF ERROR.**

1. The Court erred in reserving ruling (R 175) upon defendant's motion as follows:

defendant . . . moves this Court to dismiss Counts 1 and 2 of this Indictment for the reason that there is no proof in this case sufficient to take this case to the jury. (R 173.)



The motion was renewed after defendant's evidence (R 207) and again ruling was reserved.

2. The Court erred in not granting a mistrial when the U.S. Attorney adduced evidence of a witness, whom he had called, as follows:

Q. You are charged with murder in the State Court, are you not?

A. That is right. (R 111.)

Objection was made and sustained by the Court, motion for mistrial was made by defense counsel, and the Court instructed the jury as follows:

Members of the jury. The Court sustained the objection to the question and you should disregard the answer made, if any, and also you are not to give any effect or draw any inferences from the question and the fact that it was put (R 111).

3. The Court erred in permitting the U.S. Attorney to read from a document over the objection of counsel for the defendant. The first reading was done through a witness as follows:

Q. Look at the first page. What date does this document bear at the top?

A. That says May 29, 1956.

Q. What city?

A. Seattle, Washington.

Q. And it says by whom? (R 110).

Objection was made by defense counsel (R 110). Later the U.S. Attorney began again to read from the document and defense counsel objected as follows:

May the record show that the defendant Blas-singame objects to any reading of this statement



on the ground it is an attempt to impeach this witness without a proper foundation being laid for it? (R 113).

The Court said, "The record may so show," then the U.S. Attorney continued as follows:

Q. (By Mr. Roberts). —Johnny, in this statement, which is over your signature, the following is said: "On this date \* \* \*" May 29, 1956, "\* \* \* I was searched by Narcotic Agent L. E. Gooder in the presence of Detectives Sprinkle and Waitt. They looked in my sox and shoes even. I did not have any narcotics on my person."

Later, the U.S. Attorney continues:

Q. ". . . I was supplied with \$25.00 Government advance funds by agent Gooder. I previously had signed a receipt for Agent Fahey for this money." (R 113).

And later, he continues:

Q. "About 9:00 p.m. I met Detectives Waitt, Sprinkle, Henaby, and Kirschner at the King Street Depot as planned and then we went to the Agents Gooder and Fahey. From there we went to 19th and Roy where we all joined and I made a telephone call from the public phone booth in the presence of Detective Sprinkle."

He then continues:

"I dialed EAsT 8797 and Sam Blassingame answered. Detective Sprinkle had his ear to the phone also and he could hear the conversation on both ends."

Defense counsel interposed a running objection to which the U.S. Attorney stipulated, then the U.S. Attorney continued:

“I asked Sam how long he was going to be around, and was it all right for me to come out” . . . “He said, ‘Come on.’” (R 115).

And later, he continues:

“This is the time then I was searched and also the officers put some sort of recording device, I guess you call it, on me, and strapped it around me. I don’t know what it is other than what they have told me. I went in the Government car with Gooder and Sprinkle and Waitt to a spot south of Thomas on 22nd from where you can see “Chinkie’s’ house.” (R 115).

And later he continues:

Did you also tell the officers: “Detective Sprinkle went with me and I could see him around in the lot,” . . . (R 115).

4. The leading questions of the U.S. Attorney of his own witness though not directly objected to, counsel contends, were improper and should not have been allowed. The most harmful were:

Isn’t it a fact, Johnny, that you knocked on the door, and that Sam opened the door and let you in, and that you gave him \$25.00 in money that the agent had given you on May 29th? (R 116).

Didn’t you also tell him at that time that you wanted a spoon of stuff? (R 116).

Isn’t it a fact that at that time he took you into the living room and said he couldn’t find his stuff, and then he went to the phone and called some-

one, and asked to speak to "Chink", and then he said, "Come on home, I can't find the thing," to the party he was talking to on the phone? (R 116).

And didn't you just sit around the apartment with Sam "awhile and finally I asked him \* \* \*" didn't you ask him if you couldn't get that thing, and he just nodded his head and said, "She is coming"? (R 117).

Isn't it a fact a little while later Chinkie came in and there wasn't a word said, that she just went down to the basement and came back carrying a rubber package which she gave to Sam, and she said, I think, "I asked you if you were going to use this stuff tonight before I put it away"; didn't that take place? (R 117).

Didn't Sam take that rubber package and pour out a spoon for you right there on the couch where he was sitting? (R 117).

And isn't it a fact that after this you left the apartment and rejoined Detective Sprinkle and went and met with Sprinkle and Gooder and delivered this parcel of heroin which you just purchased from Sam? Didn't you do that on the evening of May 29th? (R 118).

5. The Court erred in not granting a mistrial, counsel contends, when the U.S. Attorney asked the following, as shown by the record on appeal at page 117,

Q. Didn't you ask him if this was the same stuff you had been——

Mr. Roberts. Strike that. I believe that is material, your Honor. I will rephrase the question.

Q. (By Mr. Roberts, continuing). Didn't you also ask Sam Blassingame at the time he was pouring this spoon for you if this was the same stuff you had been getting? (R 117).

Counsel for the defendant objected:

Mr. Chavelle. I object to that, your Honor, and ask for a mistrial. Counsel was admonished to not go into that at all, and he is referring to some other transaction, or other stuff, that this man is alleged to have obtained from the defendant. We have a stipulation it will not be referred to and it has been referred to. It is prejudicial to the defendant's case (R 117-118).

The U.S. Attorney added:

Mr. Roberts. This is a direct quote of a conversation that actually took place at the time of this sale (R 118).

The Court sustained the objection.

6. Counsel submits that it was error to submit Counts III and IV to the jury in that reasonable minds would find that there could be another hypothesis of the testimony adduced which would exclude guilt of the defendant.

---

#### ARGUMENT OF THE CASE.

The Indictment charged the appellant in four counts with violations of the Federal Narcotic Laws. Counts I and II charged violation on May 29, 1956

of Section 174, Title 21, U.S.C. and Section 4705(a), Title 26, U.S.C. Counts III and IV charged violation on June 19, 1956 of Section 174, Title 21, U.S.C. and Section 4704(a), Title 26, U.S.C. (R 3, 4).

The argument relating to the evidence offered to show unlawful acts on May 29, 1956 is upon two questions:

(1) whether the District Court erred in not granting judgment of acquittal upon Counts I and II,

(2) and whether the District Court erred in its rulings regarding evidence presented under these counts, whether the United States Attorney engaged in misconduct, in his questioning of the witness Johnny Clark, and whether the Court should not have granted a mistrial when requested by defense counsel.

The argument relating to the evidence offered to show unlawful acts on June 19, 1956 is upon two questions:

(3) whether the errors and misconduct set out above were substantially prejudicial to the defendant on his trial upon Counts III and IV.

(4) whether the evidence adduced by the Government in support of Counts III and IV of the Indictment was insufficient to take the case to the jury, or to support the verdict upon these Counts of the Indictment.

(5) and whether the error under Counts I and II may well have affected the verdict upon Counts III and IV.



treated by the Court and by the U.S. Attorney as a motion for judgment of acquittal (R 174, 175, 176). In *United States v. Goldstein*, 2nd Cir., 168 F. 2d 666, 669, the terminology "motion to dismiss" was used by the Court in discussion of the application of Rule 29(a) of the Federal Rules of Criminal Procedure. Ruling upon the motion was reserved by the Court both before the defendant put in his evidence and after the presentation of all of the evidence. Counsel contends that the reservation of decision upon the motion was error, or, at least an abuse of discretion which prejudiced the appellant upon the trial of Counts III and IV.

The applicable provision of the Federal Rules of Criminal Procedure is as follows:

#### Rule 29. Motion for Acquittal

##### (a) Motion for Judgment of Acquittal. . . .

The court on motion of a defendant or of its own motion shall order the entry of judgment of acquittal of one or more offenses charged in the indictment or information after the evidence on either side is closed if the evidence is insufficient to sustain a conviction of such offense or offenses. . . .

(b) Reservation of Decision on Motion. If a motion for judgment of acquittal is made at the close of all the evidence, the court may reserve decision on the motion, . . .

Counsel submits that the rule applies as well to a motion regarding one count of a plural indictment, as to the entire indictment. Though prior to the adoption of the Federal Rules of Criminal Procedure there

was authority that such a motion would be denied if the evidence was sufficient under any count of the indictment, presently authority and practice is different under the above quoted rule. Cases in which judgment of acquittal was rendered as to some of the counts of a plural indictment are *United States v. Bozza*, 3rd Cir., 155 F. 2d 592, and *United States v. Bianco*, D.C. Pa., 103 F. Supp. 867. Authority for this practice is found in Judgment Notwithstanding the Verdict in Federal Criminal Cases by Lester B. Orfield, Member of the United States Supreme Court Advisory Committee on Rules of Criminal Procedure, 16 Univ. of Pittsburgh Law Review 101, 115, and in Cyclopedia of Federal Procedure, 3rd Ed., Section 48.193.

Counsel contends that the submission of the matters charged under Counts I and II to the jury was prejudicial in that all counts of the indictment were related in that the same types of acts were charged, and in that the prosecution evidence tends to infer that information leading to investigation of both charges was obtained from the same source, the witness Clark. Counsel for appellant contends that the facts in this case are similar to those in *United States v. Koch*, 2nd Cir., wherein the Court said:

The appellant was tried and convicted in the District Court on an indictment in one count charging him with having conspired . . . to violate . . . (the Federal Narcotics Laws). . . The appellant requested the Court to charge, and duly took exceptions to the refusal so to do, that there was no proof that he knew that the drugs had been

imported into the United States from Canada or that he was connected with the conspiracy to import drugs into the United States from Canada in violation of Sections 173 and 174, Title 21 of the United States Code Annotated. It was error to decline to comply since that left the case as submitted generally to the jury the issue of a conspiracy to commit an offense not proved together with issues as to what we may now assume, without deciding, was an established conspiracy between appellant and Kobach to sell narcotic drugs in violation of Secs. 2553 and 2554 of 26 U.S.C.A. Int. Rev. Code. As the appellant protected his rights by properly calling the matter to the court's attention and preserving exceptions, he is entitled to a reversal.

*United States v. Koch et al.*, 2nd Cir., 113 F. 2d 982, 983, 984.

To the same effect:

*United States v. Smith*, 2nd Cir., 112 F. 2d 83;

*United States v. Groves*, 2nd Cir., 122 F. 2d 87.

Upon the merits of the Motion For Judgment of Acquittal counsel submits that the opinion of the Court in *Eng Jung v. United States*, 3rd Cir., 46 F. 2d 66, 67, is pertinent:

The government sought to draw the conclusion that the opium found in the possession of certain tenants was in the possession of the defendant. Aside from the question of possession in fact, it could not be said that there was even constructive possession. Such possession could not be assumed from the facts shown. If it be granted that the facts shown are sufficient to raise a suspicion

against the defendant, verdicts in criminal cases cannot rest on suspicion. The sanction of the law requiring proof of guilt, beyond a reasonable doubt, intended for the protection of innocence, must be steadily observed.

In a case where the evidence is circumstantial, the test to be applied is "whether as a matter of law reasonable minds, as triers of the fact, must be in agreement that reasonable hypotheses other than guilt could be drawn from the evidence."

*Remmer v. United States*, 9th Cir., 205 F. 2d 277, 287, 288.

Counsel contends that reasonable minds must find that upon Counts I and II that the persons known to be in the building other than the defendant, or other persons may have supplied the informer with narcotics, without the defendant being involved in any way; and therefore counsel contends that it was an abuse of discretion to reserve a ruling upon the defendant's motion, and that allowing that evidence to go to the jury was prejudicial to the decision upon Counts III and IV, as hereinafter shown.

---

## II.

**THAT THERE WAS ERROR OF THE COURT AND MISCONDUCT OF THE UNITED STATES ATTORNEY IN RELATION TO THE TESTIMONY OF JOHNNY CLARK.**

The U.S. Attorney adduced the following evidence from the witness, Johnny Clark, whom he had called, "You are charged with murder in the State Court,



are you not? A. That is right.” Objection made by defense counsel was sustained, motion for mistrial was made, and the Court sustained the objection and instructed the jurors to take no note of the question or the answer (R 111). However oblique reference was again made to this prosecution much later in the proceedings on prosecution’s examination of an enforcement officer: “I told Mr. Clark that this United States Attorney’s office would—should be follow through and tell the truth, this United States Attorney’s office would refer his cooperation in the case to the State’s attorney for whatever consideration they would take in their action against him” (R 170). Counsel contends that it is well established that a party may impeach his own witness only in special circumstances, and then only by cross-examination, or by prior inconsistent statements. Counsel contends that even if this witness had not been called by the prosecution, the question would be error in that it was not as to a conviction, but merely as to a prosecution. In *Verro v. United States*, 3rd Cir., 95 F. 2d 504, conviction was reversed solely because of error in allowing cross-examination as to arrest of a witness, and the same was true in *Terzo v. United States*, 8th Cir., 9 F. 2d 357. The following cases disapprove of examination of a witness regarding possible crime not resulting in conviction: *Sousa v. United States*, 9th Cir., 5 F. 2d 9; *Dawson et al. v. United States*, 9th Cir., 10 F. 2d 106, Cert. den. 271 U.S. 687, 70 L. Ed. 1152, 46 S. Ct. 638; *Mitrovich v. United States*, 9th Cir., 15 F. 2d 163.



Upon calling Johnny Clark to testify, the U.S. Attorney asked several introductory questions, and then asked questions as to two points upon the material issues, to which he received an answer that did not support his case. The first was as to whether a telephone call was made, and the second was "State whether or not you purchased any narcotics with money that was given to you by the officers specifically so that you could buy some narcotics with that money on that night." To both the witness answered no. Then in the presence of the jury the U.S. Attorney claimed surprise (R 91). Then outside the presence of the jury a document, which, according to the later testimony of Clark, was signed by Clark, was read. Agent Fahey had testified earlier that on May 29, 1956 at the "Narcotics Office", "We took a statement, I reduced it to writing—a statement from Mr. Clark. . . ." (R 69). The Court, after a statement by the U.S. Attorney (R 95, 96), ruled that the government was entitled to claim surprise (R 104). However, much later in the trial a federal narcotics officer testified on direct examination by the U.S. Attorney, "I had reason to believe that Johnny Clark would not cooperate with our office in this matter" (R 171). Upon the issue of claim of surprise counsel for the defendant, prior to the Court's ruling argued to the Court as follows, "But there is one other thing that must be apparent to the Court, and that is that some affirmative damage must be done to the case. This witness has testified to nothing practically, at this point. He simply says that nothing happened" (R 96, 97).

Objection was made by counsel for the defendant repeatedly to any reading of the purported statement which had not been formally admitted to evidence, on the ground that there was not a sufficient foundation for it (R 110, 112, 113, 114).

Counsel for the appellant contends that the proper foundation for prior inconsistent statements was not laid here because testimony claimed to be surprising to the U.S. Attorney was merely negative in its effect on the government's case.

“. . . if a party interrogates a witness about a fact which would be favorable to the examiner if true and receives a reply which is merely negative in its effect on examiner's case, the examiner may not by extrinsic evidence prove that the first witness had earlier stated that the fact was true as desired by the enquirer. An affirmative answer would have been material and subject to be impeached by an inconsistent statement, but a negative answer is not damaging to the examiner, but merely disappointing and may not be thus impeached.”

McCormick, Evidence, Sec. 36 at P. 67.

After the jury was returned to the courtroom, the U.S. Attorney resumed his examination of the informer and made a more extensive examination (R 107, 108, 109, 112) than had been made before the claim of surprise. When asked whether he had made a written statement to the Federal Bureau of Narcotics about buying narcotics on the night in question, the informer, Clark, refused to answer, claiming the privilege of the fifth amendment against self-incrimi-

nation (R 109). Thereafter the U.S. Attorney showed the purported statement to the witness, and he testified that it was the first time that he had seen it "knowing what was on it" (R 109, 110, 111).

The U.S. Attorney did not offer the purported statement into evidence, but nevertheless caused the statement to be read in part (R 110), and read from it himself, prefacing the statement with the remark, "Johnny, in this statement, which is over your signature, the following is said: . . ." (R 113). Objection was made by defense counsel to these readings from the document (R. 110, 112, 113, 114). Although there appears to be a conflict of authority upon the question, there is authority which holds that mere proof of signature to a purported written statement is not sufficient to allow it to be admitted as evidence of prior inconsistent statements. In *Hoagland v. Canfield*, 160 Fed. 146, 164, 165, where the witness admits the signature, but denies having read the statement, though he admitted having made a statement to the investigator who wrote the statement, the Court held that the paper was not in evidence and that counsel could not read from the paper. This rule seems particularly appropriate where the witness is unable to read as in *Colby v. Avery*, 40 Atl. 2d 841. In *Altieri v. Public Service Ry. Co.*, 103 N.J.L. 351, 93 N.H. 250, 135 Atl. 786, 787 it was held that the trial Court did not err in excluding a signed written declaration of facts, denied by witness and offered to impeach him, where neither the party who wrote the statement nor any one else testified that the declaration contained a true account of what the witness said.

The testimony of this witness before surprise was claimed covers less than two pages of the record on appeal (R 90, 91). His actual testimony after surprise was claimed covers eleven pages of the record on appeal (R 106 through 117). Neither in the questioning before the surprise was claimed nor in the subsequent questioning before the informer was confronted with the purported statement, was the informer asked whether he had made a purchase of narcotics from the appellant (R 89, 90, 91, 106, 107, 108, 109), but numerous questions bearing upon that issue were later propounded (R 116, 117) and part of one question contained the words, “. . . this parcel of heroin which you just purchased from Sam?” (R 118).

The record shows that in the extensive cross-examination of the witness Clark, both before and after the reading of the purported statement, there was never any indication that the cross-examination would elicit from the witness any testimony favorable to the prosecution. Counsel for the appellant submits that the form of these questions was narrative, and that they were not concentrated upon the subjects of the questions which were asked on direct examination.

Concerning the cross-examination and impeachment of the witness Clark counsel contends:

(1) that it was error for the Court to rule that the U. S. Attorney could proceed under claim of surprise where there was no affirmative damage to the case;

(2) that the damage, if any, caused by the questions asked after the claim of surprise, was self-inflicted



damage, and thus not the proper subject of a showing of prior inconsistent statements;

(3) if the claim of surprise was proper, that the impeachment and cross-examination of the witness was far beyond the point of surprise and greatly more extensive than necessary to explain the calling of the witness, and to contradict those answers of the witness to which here may have been true surprise.

The rule in its original and strict form against impeaching one's own witness is discredited everywhere, and it is generally recognized that impeachment may be resorted to where a witness has surprised the party offering him, by his testimony. . . . Further, it is equally fundamental that the impeaching testimony be admitted not for the purpose of supplying what the witness was expected to, but did not, say as a basis for a verdict, but only to eliminate from the jury's minds any positive adverse effect which might have been created by the testimony which has surprised the offeror . . . "On a showing to the court that it ought not to be bound by what (the witnesses it offered) had testified, because it had been entrapped by them," *New York Ins. Co. v. Bacalis*, 5 Cir., 94 F.2d 200, 202, the court may, in the exercise of its discretion, limiting the impeaching matter to the point of the surprise, permit evidence to remain in the record for such weight as it may have in the light of its impeachment, and of a careful instruction by the court, that the impeaching evidence is not at all admitted as evidence in the offerer's favor, but for what effect it may have in overcoming the testimony which has surprised the offerer. In short, the impeaching and contradictory statements are "ad-



mitted only to destroy the credit of the witnesses, to annul and not to substitute their testimony.” Id. . . . Neither even where there is a real surprise, is it proper to permit the impeaching testimony to go beyond the only purpose for which it is admissible, the removal of the damage the surprise has caused. In no event may the fact that a witness has made contradictory statements be used as it was here, as a basis for completely discarding the rules of evidence against hearsay and ex parte statements, and damaging hearsay. *Dewey Ward v. United States*, 5 Cir., 96 F.2d 189. . . . All of these cases make it clear that to admit such contradictions, there must be not only surprise, but damage, and the damage claimed must not have been self-inflicted by continuing to put in damaging testimony after the witness’s hostility or change of front has been discovered in order to open the gate to let his favorable ex parte statements in. *Royal Ins. Co. v. Eastham*, supra. (5 Cir., 71 F.2d 385.)

*Young v. United States*, 5th Cir., 97 F. 2d 200, 205-206, 117 A.L.R. 316.

It is the established rule that impeachment of one’s own witness may be resorted to where his testimony has surprised the party offering him. However, the impeaching matter is to be limited to the point of surprise and even where that is a real surprise it is not proper to permit the impeachment testimony to go beyond the only purpose for which it is admissible, i.e., the removal of the damage the surprise has caused. “In no event may the fact that a witness has made contradictory statements be used as it in effect was here, as a basis for completely discarding the

rules of evidence against hearsay and ex parte statements, and as impeachment, opening the floodgates of prejudicial and damaging hearsay.” *Young v. United States*, 5 Cir., 97 F.2d 200, 206. Moreover, the damage claimed must not have been self-inflicted by continuing, as here, to put in damaging statements after the witness’ hostility has been discovered.

*Culwell v. United States*, 5th Cir., 194 F. 2d 808, 811.

*Young v. United States*, supra, and *Culwell v. United States*, supra, are followed in the State of Washington. *State v. Thorne*, 260 P. 2d 331, 43 Wash. 2d 47.

That the impeachment must be limited to the point of surprise and be admitted only for the purpose of removal of the damage the surprise has caused is well settled. *Forrester v. United States*, 5th Cir., 210 F. 2d 923, 926; *Apodaca v. United States*, 5th Cir., 200 F. 2d 775.

In *Kuhn v. United States*, 24 F. 2d 910, 9th Cir., this honorable Court held that where the United States Attorney questioned his own witness extensively as to prior inconsistent statements, where only a few questions to that witness had indicated that he either did not know anything of the issues or that he was not going to cooperate, there was error. However as the Court made frequent admonitions and as the U. S. Attorney on his own motion consented that the testimony be withdrawn, and for other reasons, this honorable Court held that the error was not

The testimony of prosecution witnesses related the witness Clark to the charges under Counts III and IV (R 70, 71, 120, 133, 134, 160), by testimony referring to a conference upon the evening of June 19, 1957. It was testified, "At that meeting we had a conversation with Johnny Clark" (R 160). "We held a short conference and immediately Agent Du Puis, Chan Kirschner and I raced to the fire plug at 26th and East Thomas" (R 71).

Thus counsel raises the question of whether error in evidence primarily submitted to prove Counts I and II did not prejudice the trial of Counts III and IV, because of an implication that the witness Clark had forecast illegal activities on the part of the defendant, on the day referred to in Counts III and IV.

---

#### IV.

**THAT THE EVIDENCE ADDUCED UNDER COUNTS III AND IV WAS NOT SUFFICIENT UPON WHICH TO BASE A VERDICT OF GUILTY.**

Testimony as to what occurred at 26th and East Thomas on the evening of June 19, 1956 was given by Charles Fahey, and Charles F. Du Puis, treasury agents for the Bureau of Narcotics, and C. F. Kirschner, Detective, Narcotics Detail, Seattle Police Department (R 70, 120, 129). They and other officers met with Johnny Clark at Seventh and Madison, and there was "a short conference" (R 71) and "immediately Agent Du Puis, Chan Kirschner and I raced to the fire plug at 26th and East Thomas." (R 70, 71).

In describing the intersection at 26th and East Thomas Agent Fahey testified that East Thomas does not continue west beyond its intersection with 26th Street, and that looking to the west of the intersection "you are looking directly into a brushy, wooded bank, with a long flight of stairs leading up to Madison." He further testified that there was a fire plug on the southeast corner of the intersection. He testified that "There is a street light, but it was not burning." (R 72, 73). Agent Kirschner testified ". . . on Madison Street there are three sodium vapor lights lighting the entire area for possibly three-quarters of the way down the stairs." And, he testified that the light condition at the base of the stairs and around that intersection "was dark—semi-dark. It wasn't too good." (R 134). Agent Du Puis, Kirschner, and Fahey then searched the region of the fire plug (R 73). Agent Fahey testified that they then all went around the corner in the auto and eastward down East Thomas, about three-quarters of a block, and parked at the curb (R 74). He further testified, "Du Puis pulled into the curb and cut his lights, and we were holding a little hurried conference, and Chan got out of the car, and we made a plan, and I am starting out and got out of the car, and my coat is hung up on the ashtray or something, and Du Puis directed our attention to the stairway and I see a man coming down the stairs." (R 74). The time from leaving the fire plug to leaving the car was "not over two minutes" (R 135). It was possible, testified Agent Kirschner, that someone could have come up to the fire plug area if they crawled, and he would not have



seen them during the time they were away from the plug (R 142). But regarding the time of the initial search of the fire plug area Agent Du Puis testified to the question, "Is it possible there were some other people around there at that time and you wouldn't see them?", "This is quite correct." (R 126). He further testified that it was possible that there could be a person or persons concealed in the wooded area (R 126). Agent Du Puis after the other officers were aware of the figure on the stairs, and after the other officers had left the auto, he allowed the auto to roll down the street, turned it around at the bottom, backing up once, then drove it up the hill (R 122, 123). He testified, "I came back up the hill, and I turned my lights on, and as I came up the hill my lights flashed on a man wearing a light top-coat. He was on the first landing of the steps running towards East Madison (R. 123). The agent testified that he recognized the man as Sam Blassingame (R. 123). Agent Fahey testified that after they left the car he and Agent Kirschner ran up the hill and that he, Agent Fahey, saw "the man . . . going fast down the stairs." He testified, "about the time the man is standing over the fire plug, I can feel headlights, and I hit dirt," about sixty or fifty feet from the fire plug (R 74, 75). He testified that he started to run again and the man had gone at a trot up about four steps, and "whirled around looking" and that the "car's headlights have him tagged on the steps" and that it was the defendant (R 75). He joined Agent Kirschner and they made no pursuit though the man was pacing at the top of the steps, fifty or sixty feet away (R 76).



The agents discovered a package next to the fire plug, they testified (R 76), and other testimony identified the contents of the package as heroin.

Agent Du Puis testified that he was away from the intersection five to ten minutes, and that when he returned a man other than Sam Blassingame was in custody (R 126). Concerning this arrest Agent Kirschner testifies that he and Agent Fahey, saw a car come up East Thomas, go around the corner and park on 26th, and a man got out who came up to the fire plug area and was arrested (R 145, 146). Sam Blassingame was available for arrest at all times from June 19, 1956 to September 27, 1956, (R 156), but the arrest was not made until September 27, 1956.

Counsel for the appellant questions whether the evidence is sufficient to establish possession in the defendant. They submit under the testimony reasonable minds would find that someone other than the man seen coming down the stairs, and testified to have been later identified as defendant, could have thrown the evidence from a concealed position nearby, or could have crept to the fire plug, both while the officers were parked down the hill. Counsel contends that such a possibility is logical in that it is reasonable to suppose that acts of the nature charged would be done furtively.

If it be granted that the facts shown are sufficient to raise a suspicion against the defendant, verdicts in criminal cases cannot rest on suspicion. The sanction of the law requiring proof of guilt, beyond reasonable doubt, intended for the

protection of the innocence, must steadily be observed.

*Eng Jung v. United States*, 3rd Cir., 46 F.2d 66, 67.

Possession of the instruments or fruits of crime by a defendant in order to be incriminating must have been known to him, actual, dominant, with plenary power of disposition.

*Grantello v. United States*, 8th Cir., 3 F.2d 117, 118.

---

## V.

THAT HAD THERE BEEN NO PREJUDICIAL ERROR AND HAD THE MATTERS UNDER COUNTS I AND II NOT BEEN SUBMITTED TO THE JURY, THE JURY MIGHT WELL HAVE FOUND A VERDICT OF NOT GUILTY UPON COUNTS III AND IV.

Counsel for appellant contend that the errors and misconduct of the U. S. Attorney tended to place an onus of guilt upon the defendant. Stripped of that evidence which related to Counts I and II, there might well have been reasonable doubt as to the evidence under Counts III and IV. Counsel submits that in some particulars the evidence of the law enforcement officers is conflicting, and that the hypothesis of guilt is based upon an involved chain of testimony, many links of which might easily be doubted. Counsel submit that the entire consideration of Counts III and IV may well have been clouded by the jury's concurrent consideration of the evidence under Counts I and II, by the erroneous evidence admitted against the defendant under Counts I and

II, and by the inference that the government had been forewarned by Johnny Clark, about whom evidence was erroneously admitted, that the defendant would engage in criminal conduct at the place and time referred to in Counts III and IV.

We conclude that where the entire record affirmatively discloses that an error has not affected the substantial rights of an appellant, it will be disregarded. But where error occurs which, within the range of a reasonable possibility, may have affected the verdict of a jury, appellant is not required to explore the minds of the jurors in an effort to prove that it did in fact influence their verdict. . . . The record failing affirmatively to disclose that no prejudice did result, the verdict cannot stand.

*Little v. United States*, 10th Cir., 73 F.2d 861, 866, 867.

---

### CONCLUSION.

Appellant believes that this honorable Court should reverse the judgment heretofore imposed because of the foregoing specified errors.

Wherefore, it is respectfully requested the judgment imposed in said cause be reversed.

Dated, San Francisco, California,  
December 20, 1957.

BENJAMIN M. DAVIS,

JAMES W. FUNSTEN,

*Attorneys for Appellant.*

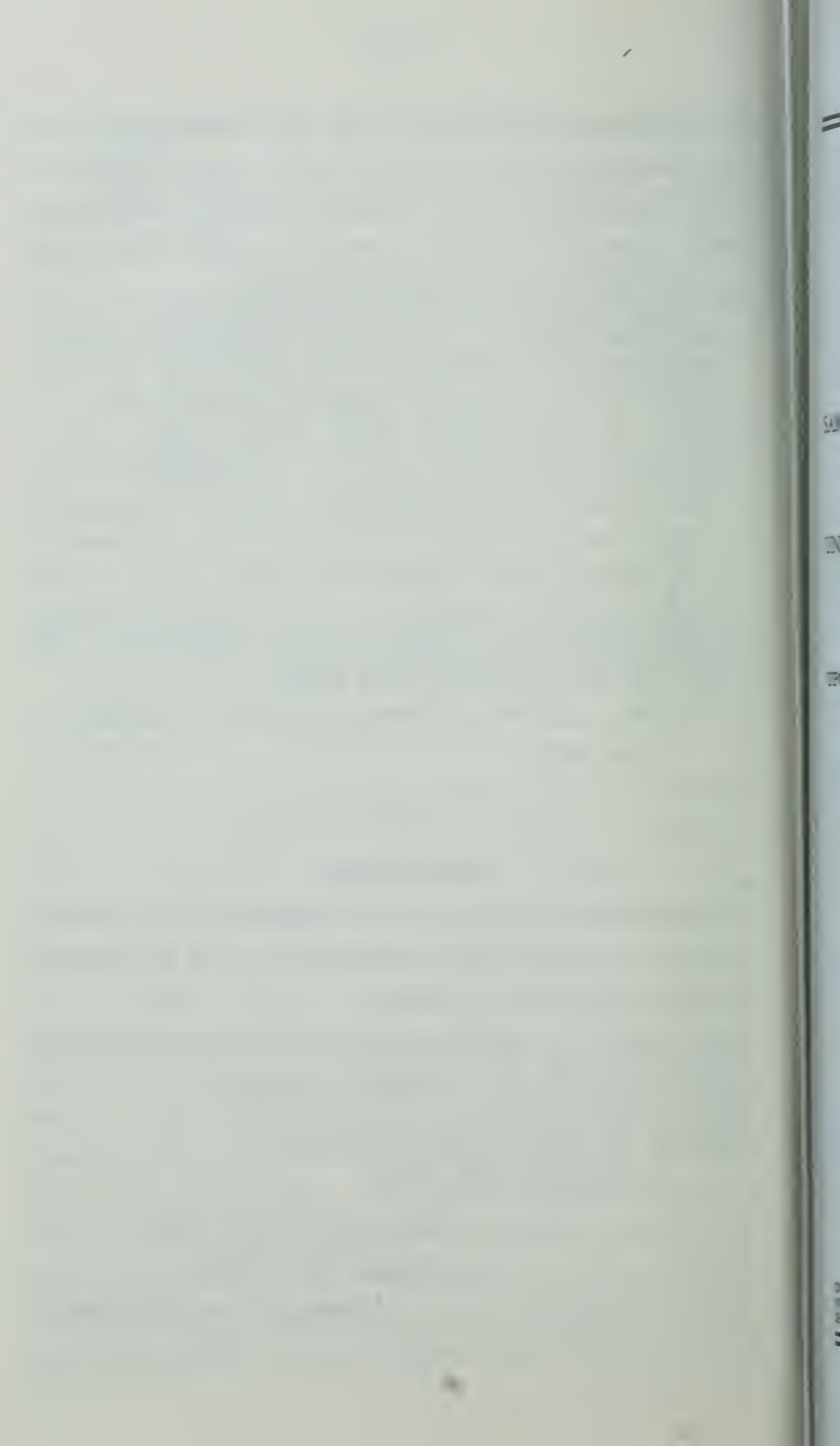

United States  
Court of Appeals  
FOR THE NINTH CIRCUIT

---

SAM BLASSINGAME,

*Appellant,*

v.

UNITED STATES OF AMERICA,

*Appellee.*

---

UPON APPEAL FROM THE UNITED STATES DISTRICT COURT  
FOR THE WESTERN DISTRICT OF WASHINGTON,  
NORTHERN DIVISION

---

HONORABLE WILLIAM J. LINDBERG, *Judge*

---

BRIEF OF APPELLEE

---

CHARLES P. MORIARTY

*United States Attorney*

*Western District of Washington*

JEREMIAH M. LONG

*Assistant United States Attorney*

*Attorneys for Appellee*

OFFICE AND POST OFFICE ADDRESS:  
1012 UNITED STATES COURTHOUSE  
SEATTLE 4, WASHINGTON

---

---

FILED

JAN 25 1958





United States  
Court of Appeals  
FOR THE NINTH CIRCUIT

---

SAM BLASSINGAME,

*Appellant,*

v.

UNITED STATES OF AMERICA,

*Appellee.*

---

UPON APPEAL FROM THE UNITED STATES DISTRICT COURT  
FOR THE WESTERN DISTRICT OF WASHINGTON,  
NORTHERN DIVISION

---

HONORABLE WILLIAM J. LINDBERG, *Judge*

---

BRIEF OF APPELLEE

---

CHARLES P. MORIARTY

*United States Attorney*

*Western District of Washington*

JEREMIAH M. LONG

*Assistant United States Attorney*

*Attorneys for Appellee*

OFFICE AND POST OFFICE ADDRESS:  
1012 UNITED STATES COURTHOUSE  
SEATTLE 4, WASHINGTON

---

---



## INDEX

	Page
STATEMENT OF JURISDICTION.....	1
QUESTION PRESENTED .....	1
COUNTERSTATEMENT OF THE CASE.....	2
SUMMARY OF ARGUMENT.....	7
ARGUMENT	
I. <i>There Was no Prejudicial Error in Permitting the Government to Impeach Its Own Witness Nor in the Manner Impeachment Was Conducted</i> .....	11
II. <i>The Trial Court Did Not Err in Refusing to Grant a Mistrial</i> .....	18
III. <i>The Court Did Not Err in Reserving Ruling On Motion for Judgment of Acquittal on Counts I and II</i> .....	26
IV. <i>Error, If Any, With Relation to Evidence Adduced Under Counts I and II Did Not Prejudicially Affect the Jury's Verdict on Counts III and IV</i> .....	29
V. <i>The Evidence Is Conclusive in Support of the Conviction Under Counts III and IV</i> .....	31
CONCLUSION .....	34

## TABLE OF CASES

<i>D'Aquino v. United States</i> , 192 F. 2d 338 (C.A. 9, 1951), cert. den. 343 U.S. 935.....	23
<i>Enriquez v. United States</i> , 188 F. 2d 313 (C.A. 9, 1951)....	25
<i>Glasser v. United States</i> , 315 U.S. 60 (1941).....	31
<i>Miranda v. United States</i> , 196 F. 2d 408 (C.A. 9, 1952), cert. den. 344 U.S. 842.....	25, 26, 29

ii                    TABLE OF CASES (*Continued*)

	Page
<i>Noell v. United States</i> , 183 F. 2d 334 (C.A. 9, 1950).....	20
<i>Nye &amp; Nissen v. United States</i> , 168 F. 2d 846 (C.A. 9, 1948), affirmed 336 U.S. 613.....	19, 25
<i>Opper v. United States</i> , 348 U.S. 84 (1954).....	19
<i>Remmer v. United States</i> , 205 F. 2d 277 (C.A. 9, 1953), reversed 347 U.S. 227.....	28
<i>Remus v. United States</i> , 291 Fed. 501 (C.A. 6, 1923), cert. den. 263 U.S. 717 .....	19 - 20
<i>Rowland v. United States</i> , 207 F. 2d 621 (C.A. 9, 1953)....	27
<i>Sawyer v. United States</i> , 202 U.S. 150 (1906).....	24
<i>Smith v. United States</i> , 173 F. 2d 181 (C.A. 9, 1949).....	20
<i>Souza v. United States</i> , 5 F. 2d 9 (C.A. 9, 1925).....	23
<i>Stein v. United States</i> , 166 F. 2d 851 (C.A. 9, 1948), cert. den. 334 U.S. 844.....	25
<i>Stoppelli v. United States</i> , 183 F. 2d 391 (C.A. 9, 1950), cert. den. 340 U.S. 864.....	24
<i>Tedesco v. United States</i> , 118 F. 2d 737 (C.A. 9, 1941).....	25
<i>Todorow v. United States</i> , 173 F. 2d 439 (C.A. 9, 1949), cert. den. 337 U.S. 925.....	32
<i>United States v. Calderon</i> , 348 U.S. 160 (1954).....	27
<i>United States v. Curzio</i> , 179 F. 2d 380 (C.A. 3, 1950).....	24
<i>United States v. Goldstein</i> , 168 F. 2d 666 (C.A. 2, 1948)....	27
<i>United States v. Goodman</i> , 110 F. 2d 390 (C.A. 7, 1940)....	31
<i>United States v. Sacony-Vacuum Oil Co.</i> , 310 U.S. 150 (1940) .....	24
<i>Weaver v. United States</i> , 216 F. 2d 23 (C.A. 9, 1954).....	14
<i>Wright v. United States</i> , 192 F. 2d 595 (C.A. 9, 1951).....	25



## STATUTES

	Page
21 U.S.C. 174 .....	3
26 U.S.C. 4704(a) .....	3
26 U.S.C. 4705(a) .....	3

## FEDERAL RULES OF CRIMINAL PROCEDURE

Rule 29(b) .....	10, 27
------------------	--------

## OTHER AUTHORITIES

2 Wigmore, <i>Evidence</i> , 3d Ed., 1940, §§ 302-304.....	25
--	----

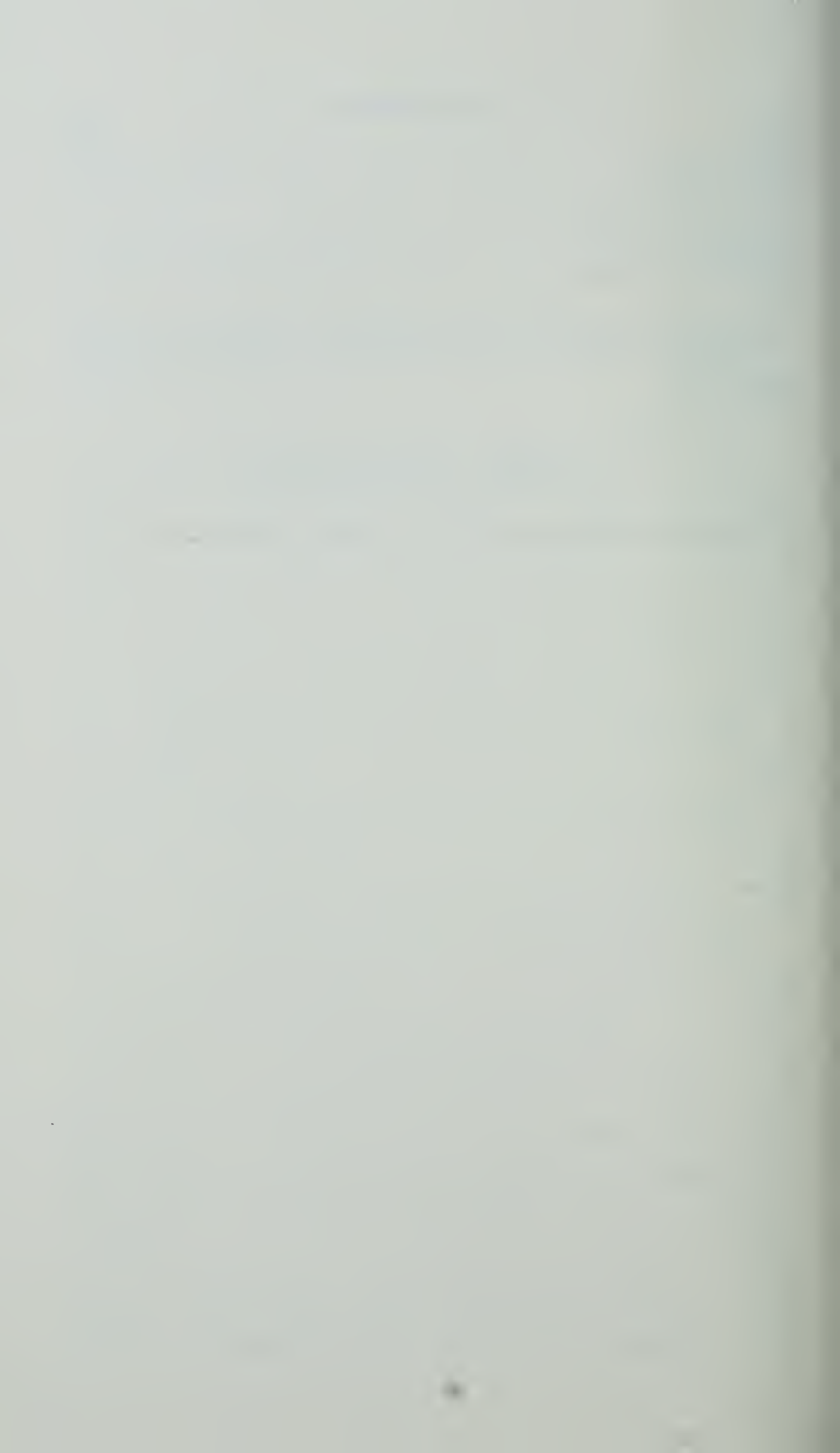

United States  
Court of Appeals  
FOR THE NINTH CIRCUIT

---

SAM BLASSINGAME,

*Appellant,*

v.

UNITED STATES OF AMERICA,

*Appellee.*

---

UPON APPEAL FROM THE UNITED STATES DISTRICT COURT  
FOR THE WESTERN DISTRICT OF WASHINGTON,  
NORTHERN DIVISION

---

HONORABLE WILLIAM J. LINDBERG, *Judge*

---

BRIEF OF APPELLEE

---

STATEMENT OF JURISDICTION

Appellee accepts appellant's statement of jurisdiction.

QUESTIONS PRESENTED

- I. Whether there was prejudicial error in permitting the Government to impeach its own witness or in the manner impeachment was conducted.

- II. Whether the Court erred in refusing to grant a mistrial:
- A. When the Assistant United States Attorney asked his witness whether he was charged with murder in the State Court where the subject matter was previously brought out by the defense.
  - B. When the Assistant United States Attorney referred to previous purchases of narcotics in examination of his witness.
- III. Whether the Court prejudicially erred in reserving ruling on motion for judgment of acquittal on Counts I and II.
- IV. Whether error, if any, with relation to evidence adduced under Counts I and II, of which counts the defendant was acquitted, prejudicially affected the jury's verdict on Counts III and IV.
- V. Whether there was sufficient evidence to support the conviction under Counts III and IV.

### COUNTERSTATEMENT OF THE CASE

On September 12, 1956, an indictment was returned in the District Court of the United States for

the Western District of Washington, Northern Division, in Cause No. 49488 charging the appellant, Sam Blassingame, with four violations of the federal narcotic laws (Tr. 3-5). Counts I and II of the indictment charged violations on May 29, 1956, of Section 174, Title 21, U.S.C., and Section 4705(a), Title 26, U.S.C. Counts III and IV charged violations on June 19, 1956, of Section 174, Title 21, U.S.C., and Section 4704(a), Title 26, U.S.C.

Following a trial by jury on January 15 and 16, 1957, appellant was found not guilty on Counts I and II and guilty on Counts III and IV (Tr. 5). He was sentenced on January 28, 1957, to five years imprisonment and ordered to pay a \$2,000 fine on each guilty count. The execution of the sentence imposed on Count IV was to run consecutive to and not concurrent with the execution of the sentence imposed on Count III (Tr. 7 - 8).

The evidence adduced by the Government at the trial may be summarized as follows as to Counts I and II:

On May 29, 1956, at approximately 9 o'clock in the evening federal and state narcotic enforcement officers with one Johnny Clark proceeded to a public telephone booth on the northeast corner of 19th and Roy Streets, Seattle, Washington (Tr. 12). Johnny



Clark and Chester G. Sprinkle, a narcotic officer for the Seattle Police Department, entered the phone booth and Johnny Clark dialed a number (Tr. 13). Clark asked Sam Blassingame, the man at the other end of the phone, if it was all right to come by (Tr. 13-14). Sam Blassingame answered, "Yes" (Tr. 17).

After the phone call Clark entered one of the Government cars (Tr. 17) and Agent Gooder, a federal narcotic officer, thoroughly searched Clark's person and clothing for narcotics (Tr. 51, 56-57). No narcotics were found (Tr. 51). He was then given \$25.00 Government advance funds by Agent Gooder (Tr. 51), who drove Clark to 22nd Avenue and parked just south of East Thomas, Seattle (Tr. 52). Clark walked up to the back door of the house on 22nd and East Thomas, knocked on the door, and in a few moments was admitted by Sam Blassingame (Tr. 17-18). Subsequently, while Clark was in the building, Bernice Fitzgerald drove up to the house in an automobile and entered the same door Clark had previously entered, and within three minutes left in her automobile (Tr. 18). During the period of time Clark was in the house the door of the other side of the duplex opened and a man other than Blassingame swept off the back porch (Tr. 19). Later, the door Clark entered opened and Sam Blassingame stuck his head out, looked in both directions, stepped back in, and Clark came out (Tr. 19). Clark returned

to the Government car and turned over to Agent Gooder a small white paper bindle (Tr. 53) which contained heroin (Tr. 56).

Motion to dismiss Counts I and II, treated as a motion for judgment of acquittal, was made at the conclusion of the prosecution's evidence and ruling was reserved (Tr. 173 - 175). The defense introduced its case and at the conclusion thereof renewed its motion as to Counts I and II (Tr. 207). The Court reserved ruling with agreement by the defense (Tr. 207). The jury found the defendant not guilty upon these counts.

As to Counts III and IV, the evidence introduced by the Government at the trial may be summarized as follows:

On the 19th of June 1956, federal and City of Seattle narcotic officers, shortly after 9 p.m., met at Seventh and Madison, Seattle (Tr. 133). After a short conversation, Federal Narcotic Agents Fahey and DuPuis and Seattle Narcotic Detective Kirschner proceeded to 26th North and East Thomas Street, Seattle, (Tr. 71) where Kirschner got out of the car and, using a flashlight, searched the area around a fireplug at that intersection (Tr. 135). DuPuis, who was driving, parked the car, took his flashlight, and all three officers searched the area around the fireplug (Tr. 73).

The officers then got in the car and proceeded down Thomas Street to an alley approximately three-quarters of a block from the intersection (Tr. 74), Officer Kirschner having a view of the intersection at all times (Tr. 135). DuPuis called the other officers' attention to someone coming down the stairway from East Madison Street to the fireplug (Tr. 136). Kirschner and Fahey proceeded back up the street on foot to within fifty feet of the fireplug (Tr. 75) and, upon feeling lights behind them, flattened out on a terrace and Kirschner watched Sam Blassingame approach the fireplug, stop, turn, and go back up the stairs (Tr. 136 - 137). Blassingame turned on the stairs at the approach of the officers' car and DuPuis and Fahey recognized Sam Blassingame in the light of headlights of the car DuPuis was driving (Tr. 75, 123). Subsequently, the three officers proceeded to the fireplug, turned on their flashlights, and found a white object next to the fireplug (Tr. 76). The time which elapsed from the first search of the area until the officers found the object was no more than five or six minutes (Tr. 77) and during that time no one but Sam Blassingame was in the vicinity of the fireplug (Tr. 77). The white object had no tax stamps affixed to it (Tr. 143) and contained heroin (Tr. 155).

Subsequently on about October 3, 1956, Kirschner had a conversation with appellant at 118 25th North,

Seattle, wherein Blassingame stated that he saw Kirschner at the fireplug (Tr. 148-150).

The jury found appellant guilty on Counts III and IV.

## SUMMARY OF ARGUMENT

### *I. There Was No Prejudicial Error in Permitting the Government to Impeach Its Own Witness Nor in the Manner Impeachment Was Conducted.*

Johnny Clark, upon being called as a witness, denied that he purchased narcotics on May 29, 1956, with money furnished by federal agents, whereupon the United States claimed surprise. The defense agreed that the Government was surprised, but objected that no damage was done to the Government's case. The Court permitted the Government to impeach Clark.

1. To assert that the Government was not damaged by this testimony ignores the previous testimony of Government agents to the contrary.

2. In addition, the matters on which Clark was questioned, except for one question relating to previous buys, were within the limits of surprise because they concerned his making a telephone call and purchasing narcotics on May 29, 1956, the subjects concerning which Clark testified prior to the claim of surprise.

3. Though the manner in which the questions

relating to Clark's prior statement asked by Government counsel may have been questionable, since that statement could have been used as the basis of impeaching questions, and since the answers given were damaging to the Government's case, there was no prejudice to the appellant.

4. The Court's instructions limiting the purpose of Clark's testimony were extensive, were agreed to by the defense and, in view of Blassingame's acquittal under Counts I and II, with which counts Clark's testimony was concerned, no prejudice occurred.

## *II. The Trial Court Did Not Err in Refusing to Grant a Mistrial.*

A. During examination of Clark by the Government, the witness was asked if he was charged with murder in the State Court.

1. There was no error in denying a mistrial because the objection raised was sustained and the jury carefully instructed to disregard the matter.

2. Clark was named by the defense much earlier in the trial as a murderer and it would be anomalous to permit appellant to introduce "murder" into the case when he felt it advantageous and claim error when it is casually referred to by the Government.

3. Further, any error relating to this matter



was obviously nonprejudicial because the jury returned a verdict of not guilty of Counts I and II, the only counts concerning which Johnny Clark testified.

B. Later, during the examination of Clark, the Government counsel asked a question concerning previous buys by Clark from Blassingame. The Court sustained objection to the question and no answer was given.

1. The Court instructed the jury extensively on the purpose of Clark's testimony, which, taken into consideration with the jury verdict acquitting Blassingame of Counts I and II, demonstrates that no prejudice resulted from asking the question.

2. Asking such a question without reply and in the light of the extensive instructions by the Court is analogous to questionable statements by counsel in argument or similar to a witness volunteering an answer indicating previous misconduct of a defendant where, when the matter is thoroughly covered in the Court's instructions, does not result in prejudicial error.

3. The matter of previous dealing in narcotics between Clark and Blassingame could have been inquired into by Government counsel to show Blassingame's knowledge or intent under the charges in this case.

III. *The Court Did Not Err in Reserving Ruling on Motion for Judgment of Acquittal on Counts I and II.*

1. By introducing evidence after the Court reserved ruling on motion for judgment of acquittal at the conclusion of the Government's evidence, the defense waived this objection, and the only question before this Court is whether or not the Trial Court erred in reserving ruling on such a motion at the conclusion of all the evidence.

2. Rule 29(b), Federal Rules of Criminal Procedure, gives the Court the right to reserve ruling at the conclusion of evidence on such a motion.

3. The defense expressly agreed to the Court's reserving ruling at the conclusion of all the evidence on the motion for judgment of acquittal.

4. There was sufficient evidence to go to the jury on Counts I and II.

IV. *Error, If Any, With Relation to Evidence Adduced Under Counts I and II Did Not Prejudicially Affect the Jury's Verdict on Counts III and IV.*

The jury's verdict on Counts I and II acquitting the defendant of these charges demonstrated that its deliberations were not affected with prejudice.

V. *The Evidence Is Conclusive in Support of the Conviction Under Counts III and IV.*

ARGUMENT

I.

*There Was No Prejudicial Error in Permitting the Government to Impeach Its Own Witness Nor in the Manner Impeachment Was Conducted.*

Upon calling Johnny Clark as a witness, after several introductory questions, the following occurred during examination by the Assistant United States Attorney:

- Q. On that evening [May 29, 1956], did you make a telephone call at all? A. No.
- Q. Did you on that evening go to the corner of 19th and Roy Street, up on Capital Hill and make a telephone call? A. No.
- Q. Pardon me? A. No, sir.
- Q. State whether or not you purchased any narcotics with money that was given you by the officers specifically so that you could buy some narcotics with that money on that night?
- A. No, sir. (Tr. 91)

Surprise was claimed by the Assistant United States Attorney. The jury was excused. Government counsel then stated:

“ . . . this morning in response to a subpoena, Mr. Clark appeared for trial about five minutes to ten.

I only asked him if he was in proper condition to testify and he said he was.

“I asked him if there was any change in his testimony from the statement he had previously given to the narcotics officers. He advised me, no, that he would tell the story straight as he had at that time.

“During the recess just ten minutes ago I again asked Mr. Clark if he had any problems concerning his testimony. He assured me he had none. He told me he would testify exactly to the truth as he had given to the agents (Tr. 95 - 96).

\* \* \* \* \*

“Mr. Koshner: Your Honor, I agree with counsel. If he is surprised, he has a right to impeach his own witness, and I have no reason to doubt it. He undoubtedly is surprised by the testimony of his own witness.” (Tr. 96)

Defense counsel then added

“But there is one thing that must be apparent to the Court, and that is that some affirmative damage must be done to the case. This witness has testified to nothing, practically, at this point. He simply says that nothing happened.”

(Tr. 96 - 97)

The Court ruled that the Government was entitled to claim surprise.

After the jury returned, Government counsel proceeded to cross-examine Clark without objection concerning making the telephone call and purchasing narcotics from Sam Blassingame on May 29, 1956 (Tr.

108). Government counsel then obtained the admission from Clark that he had signed the statement (Tr. 110) which Agent Fahey had earlier testified he had taken from Clark and reduced to writing on May 29, 1956 (Tr. 69). (The contents of this statement are set out at Tr. 93 - 95.) Clark, however, denied that he knew what was in the statement (Tr. 110). Government counsel then proceeded to read from the statement and ask after each reading "Is that a true statement?", "Did you further say?", "Did that happen?", or "Did you also tell the officers?" (Tr. 113 - 115). Defense counsel objected in the following language:

"Mr. Kosher: May the record show that the defendant Blassingame objects to any reading of this statement on the ground it is an attempt to impeach this witness without a proper foundation being laid for it." (Tr. 113)

A running objection to such reading was agreed to by the Government. (Tr. 114)

Subsequently, upon the conclusion of the Government's examination of the witness Clark, the Court extensively instructed the jury on the purpose of the questioning of Clark (Tr. 118 - 119), which instruction was agreed to by defense counsel (Tr. 119).

It is noted parenthetically that the explanation of Clark's change in his story is found in Officer Kirsch-



obligation. This could be done by cross-examination of Clark as to whether or not he made such a phone call or purchased narcotics on the night in question in order to obtain a contradiction while Clark was a witness and/or by means of a prior inconsistent statement to show that Clark at another time stated that he had made a telephone call from 19th and Roy Street on May 29, 1956, and purchased narcotics on that night.

After the Court ruled that the Government could impeach its own witness, counsel attempted to do so by means of leading questions (Tr. 108 - 109) without objection. During this examination the questions asked concerned the telephone call to Sam Blassingame and the purchase of narcotics on May 29, 1956. Failing to obtain a contradiction by the use of leading questions, counsel attempted to contradict his witness by means of a prior inconsistent statement which was marked as an exhibit (Tr. 105) but never introduced into evidence.

All matters contained in the statement of Clark upon which Government counsel's questions were based related to the telephone call or the purchase of narcotics on May 29, 1956, except one question relating to previous buys, which is discussed later in this brief. These facts were testified to by Sprinkle, Gooder and Fahey earlier in the trial. It is therefore submitted

that the questions introduced nothing new into the trial, except with regard to previous buys, and therefore were not beyond the limits of the surprise nor prejudicial.

When Government counsel commenced reading from the statement of Clark, defense counsel objected on the ground that the Government was attempting to impeach its own witness without a proper foundation being laid (Tr. 113). It is submitted that in view of Agent Fahey's testimony that on May 29, 1956, he took a statement from Clark which he reduced to writing (Tr. 69) and Clark's testimony that his signature appeared on the statement, it could have been used as the basis of impeaching questions. Further, the witness refused to answer these questions based upon his prior statement claiming the privilege against self-incrimination, or answered the questions in a manner damaging to the Government's case. With the facts in this posture it is evident that no prejudice occurred because of the manner the questions were asked.

At the conclusion of the Government's examination of Clark the Court extensively instructed the jury that the purpose of Clark's examination went solely to his credibility, to which instruction the defense explicitly agreed (Tr. 118-119). The jury's

verdict of acquittal on Counts I and II demonstrated, more than argument can, that the jury carefully heeded the admonition of the Court limiting the effect of Clark's testimony after surprise solely to the issue of his credibility and deliberated without prejudice.

## II.

### *The Trial Court Did Not Err in Refusing to Grant a Mistrial.*

A. The Assistant United States Attorney in the course of examining Johnny Clark, a special employee of the Bureau of Narcotics, whom he called as a witness, asked, "You are charged with murder in the State Court, are you not? A. That is right." (Tr. 111) Objection made by the defense counsel was sustained, motion for a mistrial was made, and the court instructed the jury as follows:

"The Court sustained the objection to the question and you should disregard the answer made, if any, and also you are not to give any effect or draw any inferences from the question and the fact that it was put." (Tr. 111)

Appellant suggests that oblique reference was made to this matter again at Tr. 170. However, much earlier in the trial before Clark was a witness, during cross-examination of federal narcotic agent Gooder by defense counsel, the following took place:

Q. What remuneration had you arranged for Johnny Clark, who has been described as a stool pigeon and informer here?

A. In previous conversation with Mr. Clark, which I had no part of, but I was there—I was there, I was present—it was brought out that any assistance that we could be, in, I believe it was some type of case pending against him.

Q. What type of case was that.

A. I am not sure. I believe it was some type of murder case.

Q. Murder case? A. Murder.

Q. Murder?

A. Murder, I believe, yes . . . ." (Tr. 57)

First, the jury was instructed as effectively as was possible that the objection was sustained, that the answer should be disregarded, and no effect or inferences should be given to or drawn from the question and the fact that it was put.

As was observed by the Supreme Court in *Opper v. United States*, 348 U.S. 84, 95 (1954) "Our theory of trial relies upon the ability of a jury to follow instructions." See also, to the same effect, *Nye & Nissen v. United States*, 168 F. 2d 846, 855 (C.A. 9, 1948), affirmed, 336 U.S. 613 (1948). Prejudice is particularly unlikely when the court's instructions are given, as they were here, promptly and clearly. *Remus v.*

*United States*, 291 Fed. 501, 510 (C.A. 6, 1923), certiorari denied, 263 U.S. 717 (1923).

Furthermore, the facts upon which the question was based and the answer to the question had previously been adduced by the defense in cross-examination of federal narcotic agent Gooder. It would be anomalous to permit appellant to introduce "murder" into a case when he thinks it advantageous and then claim error when it is later casually referred to by Government counsel. See *Smith v. United States*, 173 F. 2d 181, 183 (C.A. 9, 1949); *Noell v. United States*, 183 F. 2d 334, 338 (C.A. 9, 1950).

In addition, it is submitted that any error relating to this question was obviously nonprejudicial because the jury returned a verdict of not guilty as to Counts I and II, the only counts concerning which the witness, Johnny Clark, testified.

B. Another question whether or not the Court erred in not granting a mistrial arose later on during the testimony of the same witness, Johnny Clark.

During the cross-examination of Clark by the Government, the following occurred:

"A. I never got no narcotics from that man at no time.

"Q. Didn't you ask him if this was the same stuff you had been—



“Mr. Roberts: Strike that. I believe that is material, your Honor. I will rephrase the question.

“Q. (By Mr. Roberts, continuing): Didn’t you also ask Sam Blassingame at the time he was pouring this spoon for you if this was the same stuff you had been getting?

“Mr. Chavelle: I object to that, your Honor, and ask for a mistrial. Counsel was admonished to not go into that at all, and he is referring to some other transaction, or other stuff, that this man is alleged to have obtained from the defendant.

“We have a stipulation it will not be referred to and it has been referred to. It is prejudicial to the defendant’s case.

“Mr. Roberts: This is a direct quote of a conversation that actually took place at the time of this sale.

“Mr. Chavelle: We agreed those things could not be gone into, as to what previously happened.

“Mr. Roberts: It has a direct bearing on the conditions of a buyer and seller at the time of this transaction.

“The Court: I think rather than—it may be but out of an abundance of caution I will sustain an objection to the question.” (Tr. 117-118)

The Assistant United States Attorney asked one additional question and the Court instructed the jury as follows:

“Members of the Jury:

“The United States Attorney has just been examining this witness with respect to certain matters contained in a document that has been marked

as Exhibit No. 3. The Court wants to advise you as to the purpose of that questioning.

“It has appeared in connection with this witness that the Government has been surprised, and that they anticipated other—that this witness would testify otherwise than he has indicated on the stand.

“The Court has allowed the Government to examine this witness by the use of what are known as leading questions; in other words, permitted him to be cross-examined.

“These questions that have now been put here, which have been put after referring to this exhibit, are not to be construed as evidence of the facts contained in those questions. Those questions were put because they have some bearing upon the credibility of this witness, and while the witness has indicated his signature appears on that document, you are not to construe the questions as put to him from that document as being evidence in and of themselves insofar as this witness is concerned. The only purpose is to bring out matters that may have a bearing so far as the jury is concerned on whether or not they are going to believe this witness.

“Mr. Roberts, does that, in substance, cover the purpose?”

“Mr. Roberts: I believe it does, your Honor.

“The Court: Mr. Chavelle and Mr. Kosher?”

“Mr. Chavelle: Yes.

“Mr. Kosher: Yes” (Tr. 118-119)

Although the instructions to the jury were not that they should disregard the fact that the question was asked but that the entire testimony of Clark

after the claim of surprise should be considered by them only with regard to the credibility of Clark, it is submitted that such instruction was sufficient to eliminate the prejudice, if any, in asking the question. In this connection, it is again emphasized that the verdict of acquittal as to Counts I and II, the only counts concerning which Clark testified, demonstrated that the admonition of the Court was heeded and the jury deliberated without prejudice.

*D'Aquino v. United States*, 192 F. 2d 338 (C.A. 9, 1951), certiorari denied, 343 U.S. 935, at page 367 states:

“Our system of jurisprudence properly makes it a matter primarily for the discretion of the trial court to determine whether prejudicial misconduct has occurred. An appellate court will not review the exercise of the trial court’s discretion in such a matter unless the misconduct and prejudice is so clear that it can be said that the trial judge has been guilty of an abuse of discretion.”

The danger in such a question is that it does not logically tend to prove the offense charged. *Souza v. United States*, 5 F. 2d 9, 10 (C.A. 9, 1925). Prejudice, however, is particularly unlikely where the court’s instructions are given, as here, promptly and without fuss in disposing of what was under the circumstances, a minor problem. The trial judge “. . . had seen and heard the entire episode. He was not impressed with

the contention . . ." *United States v. Curzio*, 179 F. 2d 380, 381 (C.A. 3, 1950).

It is submitted that asking the question without reply is similar to an improper statement not substantiated by the evidence in argument where the ordinary rule is that the error is cured by withdrawing the statement. *Sawyer v. United States*, 202 U.S. 150, 167-168 (1906); *United States v. Sacony-Vacuum Oil Co.*, 310 U.S. 150, 238-240, 242-243 (1940), especially if made in the excitement of trial (see *Sawyer v. United States*, *supra*, at page 168). Here, the Court's instruction had the same effect as withdrawing the statement in that the instruction took the statement from the jury's consideration of Blassingame's guilt or innocence.

Such a question is also analogous to a witness volunteering an answer indicating previous misconduct of a defendant.

In *Stoppelli v. United States*, 183 F. 2d 391 (C.A. 9, 1950), certiorari denied, 340 U.S. 864, where a government witness volunteered answers indicating that the defendant was a known criminal narcotic dealer, in disposing of the matter, the following language was used at page 395:

"There is no merit in this complaint. The trial judge fully covered the matter by immediate ap-

appropriate instructions. We hold the incident to have had no substantial adverse effect upon the fairness of the trial. It was but a transitory incident not proximately derogating from the intrinsic fairness of the trial. In a similar situation, the Court of Appeals of the Third Circuit ruled as we do. *United States v. Curzio*, 179 F. 2d 380. See also, *Marsh v. U. S. 3 Cir.*, 82 F. 2d 703."

Furthermore, it is submitted that the question asked was not error in examination of Johnny Clark for the reason that evidence of previous dealings between Clark and Blassingame would have been admissible for the purpose of tending to show appellant's knowledge and intent in committing the acts alleged in Counts I and II. *Stein v. United States*, 166 F. 2d 851, 854 (C.A. 9, 1948), certiorari denied, 334 U.S. 844; *Enriquez v. United States*, 188 F. 2d 313, 315, 316 (C.A. 9, 1951); *Wright v. United States*, 192 F. 2d 595, 597 (C.A. 9, 1951); *Nye & Nissen v. United States*, *supra*. See also, *Miranda v. United States*, 196 F. 2d 408, 409 (C.A. 9, 1952), certiorari denied, 344 U.S. 842; *Tedesco v. United States*, 118 F. 2d 737 (C.A. 9, 1941); 2 Wigmore, *Evidence*, 3d Ed., 1940, §§ 302-304. Consequently, where the Court sustained the objection to the question, no answer was permitted by the witness, and the Court's instructions were prompt, no prejudice resulted.

Again, a persuasive factor in demonstrating the lack of prejudice to appellant by reason of asking the



question is that appellant was found not guilty of the counts concerning which Clark testified. *Miranda v. United States, supra*, at page 409.

### III.

#### *The Court Did Not Err in Reserving Ruling on Motion for Judgment of Acquittal on Counts I and II.*

Upon the conclusion of the Government's case the defense moved to dismiss Counts I and II for the reason that there was no proof sufficient to take these counts to the jury (Tr. 173). The Court reserved ruling (Tr. 175). The defense then introduced its case and at the conclusion thereof the following occurred:

"Mr. Chavelle: If the Court please, the defense rests at this time.

"The Court: All right.

"Mr. Chavelle: We would like to make a motion.

"The Court: Do you wish to make the same motion you made before?

"If agreeable with you, the Court will consider they are made as though made now, and will reserve ruling.

"Mr. Chavelle: All right.

"The Court: Is that agreeable?

"Mr. Chavelle: Yes." (Tr. 207)

By introducing evidence when the Court reserved ruling at the conclusion of the Government's

case on the defense motion to dismiss as to Counts I and II the defendant waived that motion, assuming that the motion may be considered a motion for a judgment of acquittal.

A case directly in point is *United States v. Goldstein*, 168 F. 2d 666 (C.A. 2, 1948), where ruling on defense motion at the conclusion of the Government's case was reserved and renewed at the conclusion of all the evidence and reserved again. The Court said at page 670:

“ . . . we have a situation where the appellant elected to proceed with his defense on the merits without insisting upon first having a definite ruling upon his motion. The effect of that is, we think, the same as it would have been before the new Rule. On the assumption that it was erroneous not to grant the motion, the appellant could have taken his exception and declined to defend upon the merits . . . if the evidence is short as the prosecution leaves it, he may take advantage of that. But if he amplifies the record on the facts in attempting to make a case for acquittal he must assume the risk of having the prosecution's case bolstered in the process . . . Consequently, the motion to dismiss made at the close of all the evidence is the only one now open for consideration.”

See also *United States v. Calderon*, 348 U.S. 160, 164 (1954), and

*Rowland v. United States*, 207 F. 2d 621, 622 (C.A. 9, 1953).

With regard to the motion at the conclusion of all the evidence, Rule 29(b), Federal Rules of Crim-

inal Procedure, is explicit in giving the court authority to reserve ruling. It provides in pertinent part:

“If a motion for judgment of acquittal is made at the close of all the evidence, the court may reserve decision on the motion, submit the case to the jury and decide the motion either before the jury returns a verdict or after it returns a verdict of guilty or is discharged without having returned a verdict.”

In addition, where there was express agreement of opposing counsel to the reservation (Tr. 207), the matter cannot be raised at this time.

Further, the Government submits that the evidence in the instant case was sufficient to go to the jury on Counts I and II. Where evidence is circumstantial, as it was with regard to Counts I and II, the standard to be used is set out in *Remmer v. United States*, 205 F. 2d 277, 288 (C.A. 9, 1953), reversed on other grounds, 347 U.S. 227:

“If reasonable minds *could* find that the evidence excludes every reasonable hypothesis but that of guilt, the question is one of fact and must be submitted to the jury.”

Here reasonable minds could so find. The telephone call was made to Sam Blassingame (Tr. 13); Blassingame opened the door to let Clark into the apartment (Tr. 17, 18); Clark went to see Blassingame with Government advanced funds for the purpose of purchasing narcotics (Tr. 51); he was let out

of the apartment by Blassingame (Tr. 19); and he returned without the advance funds and delivered to Fahey a package containing narcotics (Tr. 53, 56). From this evidence it is apparent that reasonable minds could find that every reasonable hypothesis but that of guilt had been excluded.

#### IV.

*Error, If Any, With Relation to Evidence Adduced Under Counts I and II Did Not Prejudicially Affect the Jury's Verdict on Counts III and IV.*

A case somewhat stronger on its facts indicating the possibility of prejudice in permitting evidence to be introduced on counts barred by the statute of limitations and permitting the invalid counts to go to the jury with the good count, decided by this Court, was *Miranda v. United States, supra*.

The appellant was charged in ten counts with making a false statement under oath as a witness in ten separate naturalization proceedings of ten different applicants. The crimes charged in the first six counts were allegedly committed more than three years before the date of the indictment. Appellant plead not guilty to all counts and prior to trial moved for dismissal of counts one to six, inclusive, on the ground that prosecution was barred by the general three-year statute of limitations. The motion was denied and

appellant was tried concurrently on counts one to six and count eight. Counts seven, nine, and ten were dismissed on the motion of the prosecution during the course of the trial. The jury returned a verdict of guilty as to count eight only and found the appellant not guilty as to the remaining counts. At page 409 this Court said:

“The principal contention pressed by appellant is that the evidence introduced for the purpose of proving commission of the crimes charged in the allegedly barred counts was inadmissible and that its allowance in evidence constituted prejudicial error. It is urged that the admission of this evidence so infected the jury’s consideration of the charge in count eight as to render the verdict of guilt on that count invalid.

“For the purposes of this decision we need not determine whether the three year statute of limitation was applicable to the offense here charged or whether prejudice might not, under any conceivable circumstances, result from compelling the accused to stand trial upon a number of counts, some of which are barred. For we find here, as was held in *Marzani v. United States*, 83 U.S. App. D.C. 78, 168 F. 2d 133, 138, affirmed by an equally divided court, 335 U.S. 895, 69 S.Ct. 299, 93 L.Ed. 431, that the error, if any, in permitting the first six counts to remain in the indictment and go to the jury was harmless. Cf. *Kotteakos v. United States*, 328 U.S. 750, 66 S.Ct. 1239, 90 L.Ed. 1557. Appellant concedes that the evidence relative to counts one to six was admissible for the limited purpose of tending to show appellant’s knowledge and intent in committing the acts alleged in count eight, *Nye & Nissen v. United States*, 336 U.S. 613, 618, 69 S.Ct. 766, 93 L.Ed.



919; see 2 Wigmore, *Evidence*, 3d ed., 1940, §§ 302-304, but complains that the jury was not instructed as to such limited purpose for which the evidence was to be considered."

After finding that the jury was adequately instructed, the opinion continues at 410:

"Another persuasive factor demonstrating the lack of prejudice to appellant by reason of the admission of testimony relative to counts one to six is that, unlike the situation in *Marzani*, supra, appellant was found innocent as to the allegedly barred counts. The reasonable inference is that the jury disbelieved testimony adduced to prove the crimes charged in those counts. Cf. *Culjak v. United States*, 9 Cir., 53 F. 2d 554, 556; *Brown v. United States*, 7 Cir., 22 F. 2d 293."

With regard to the errors of misconduct alleged, in addition to the argument above made in this connection, we add that jurors may be credited with "sufficient common sense and discrimination to enable them to evaluate conduct and remarks of counsel even if the conduct and remarks should offend ordinary standards of propriety." *United States v. Goodman*, 110 F. 2d 390, 395 (C.A. 7, 1940).

## V.

### *The Evidence Is Conclusive in Support of the Conviction Under Counts III and IV.*

The standard to be used in examining the sufficiency of evidence is set out in *Glasser v. United States*, 315 U.S. 60, 80 (1941):

“It is not for us to weigh the evidence or to determine the credibility of witnesses. The verdict of a jury must be sustained if there is substantial evidence, taking the view most favorable to the Government, to support it.”

Again, this Court framed the standard in the following language in *Todorow v. United States*, 173 F. 2d 439 (C.A. 9, 1949), certiorari denied, 337 U.S. 925.

“The contention calls for an examination of the basic facts as the jury could have found them from the evidence if every conflict in the testimony had been resolved in favor of the appellee.”

The basic facts as the jury could have found them from the evidence if every conflict in the testimony had been resolved in favor of the appellee are as follows:

Detective Kirschner, Agent Fahey and Agent DuPuis searched with flashlights the area surrounding the fireplug located at 26th North and East Thomas Street, Seattle, shortly after nine o'clock on the evening of June 19, 1956 (Tr. 71 - 73). They then proceeded down Thomas Street about three-quarters of a block (Tr. 74), Kirschner having a view of the intersection at all times (Tr. 135). When DuPuis called Kirschner and Fahey's attention to someone coming down the stairway to the intersection from East Madison Street, Kirschner and Fahey proceeded on foot to

within fifty feet of the fireplug (Tr. 136-137). Kirschner watched Blassingame approach the fireplug, stop, turn, and then go back up the stairs to East Madison (Tr. 136-137). At the approach of DuPuis' car, Blassingame stopped, turned, and in the light from the headlights of DuPuis' car, Fahey, Kirschner and DuPuis all clearly recognized Blassingame (Tr. 123). Subsequently, upon a search of the fireplug area the officers found a white object next to the fireplug (Tr. 76). The time which elapsed from the time of the first search of the area until the officers found the object was no more than five or six minutes during which time no one but Blassingame was in the vicinity of the fireplug (Tr. 77). The white object had no tax stamps affixed to it (Tr. 143) and contained heroin (Tr. 155).

Subsequently, on about October 3, 1956, Kirschner had a conversation with Sam Blassingame at 118 25th North wherein Blassingame stated he saw Kirschner at the fireplug (Tr. 148 - 149).

It is submitted that the evidence conclusively supports the conviction under Counts III and IV.

## CONCLUSION

We submit that no prejudicial error occurred during the trial, which was conducted with conspicuous fairness, and that the evidence was conclusive in support of the conviction under Counts III and IV. We ask that the judgment be affirmed.

Respectfully submitted,

CHARLES P. MORIARTY  
*United States Attorney*

JEREMIAH M. LONG  
*Assistant United States Attorney*













